



G&B Specialties, Inc.
A Global Railway Industries Company



MIO-B46RXR20229 (Rev A)

**INSTALLATION OF
REAR HYDRAULIC BRAKE KIT**

**ROTARY REAR R-460 RAILGEAR
HD ROTARY REAR R-460 RAILGEAR**



SAFETY PRECAUTIONS

If any installation problems are encountered, please call G&B Specialties, Inc. for technical assistance before continuing with the installation process.



- Failure to heed to any of the following warnings could result in severe bodily injury and/or equipment damage.
- Read and understand this manual completely before attempting installation of the equipment.
- Installation instructions provided below only address the Rafna railgear equipment. Applicable railway company procedures and policies must be adhered to.
- Before performing any work under the vehicle or railgear, ensure the engine is turned off and the parking brake is set.
- Beware of all pinch points on the railgear and keep all parts of the body clear.
- When routing hydraulic hoses, ensure that the hoses do not contact any sharp edges or hot surfaces.
- All wire connections should be soldered and heat shrink sealed to prevent future corrosion-related problems.
- All wires must be covered with protective cable loom.
- Always disconnect the vehicle's battery when welding on the vehicle or railgear in order to protect the vehicle's electrical system.
- Do not use regular brake fluid in the rear hydraulic brake system, as it will damage the hydraulic brake pump and the brake cylinders.



INSTALLATION OF REAR HYDRAULIC BRAKE KIT

The following procedure details the installation of the Rear Hydraulic Brake Kit on the rear railgear. The hardware required for this installation is listed in Table 1.

Part Number	Description	Quantity
R-20229D	Hydraulic Brake Assembly, Drivers Side	1
R-20229P	Hydraulic Brake Assembly, Passengers Side	1
R-20231R-A	Mounting Bracket, RHS	1
R-20231L-A	Mounting Bracket, LHS	1
R-20164R	Mounting Bracket, RHS	1
R-20164L	Mounting Bracket, LHS	1
719-FSO-06-04	Reducer, 3/8 Male ORB x 1/4 Female ORB	1
845-FSO-40-04	TEE, 1/4 Male JIC x 1/4 Male ORB	1
844-FS-04-04	TEE, 1/4" Male JIC to 1/4" Male JIC	1
HFS2-04	Hose 36" Long	1
HFS2-04	Hose 84" Long	1
HFS2-04	Hose 360" Long	1
HU04-04NJ	1/4" Female Hose Straight Coupling (Installed on hoses)	4
HU04-04MF	1/4" Male Swivel Inverted Coupling, 45° Swivel (Installed on hoses)	2
R-990KIT-269	H.H.C.S, 1/2" UNC X 1.500, GR.8	16
	F'WASHER, 1/2" TYPE-A, GR.8	32
	Jam Nut, 1/2" UNC GR.8	16

1. Ensure that the rail wheels have been installed on the rear railgear prior to installation of the Rear Hydraulic Brake Kit.
2. Starting with the Drivers or the Passengers side, assemble the RHS and LHS mounting brackets to the wheel mounting tables as follows:
 - Remove the 1/2" wheel mounting hardware from either side of the rail wheel, as shown.
 - Assemble the mounting bracket to the wheel mounting table and rail wheel, as shown.
 - Loosely tighten the wheel mounting hardware.
 - Repeat for the (3) remaining mounting brackets
3. Assemble the Brake assemblies to the mounting brackets as shown, ensuring that the brake housings are on the correct sides of the railgear axle. The brake shoe linkage of each brake housing should be toward the front of the vehicle. It may be necessary to loosen the wheel mounting hardware to allow the mounting brackets to be adjusted for proper assembly. Torque the 1/2" x 1.50" bolts to 75 ft-lbs dry. Tighten, but do not torque, the wheel mounting hardware.



4. Ensure that the brake pump has been installed per the front brake installation manual.
5. Remove the 90° fitting installed on the hydraulic brake pump and replace with the 3/8 Male ORB x 1/4 Female ORB adapter onto the pump.
6. Install the 1/4 Male JIC x 1/4 Male ORB onto the adapter.
7. Connect the loose end of the 32" hose for the front brakes to one side of the TEE.
8. Connect the loose end of the 360" hose for the rear brakes to the other side of the TEE.
9. Route the 360" hose to the rear railgear as required and connect the 1/4" Male JIC TEE fitting to the loose end of the 360" long hose.
10. For the drivers side, connect one end of the 36" long hydraulic hose to the drivers side brake cylinder and the other end the TEE attached to the loose end of 360" hose.
11. For the passengers side, connect one end of the 84" long hydraulic hose to the passengers side brake cylinder and the other end the TEE attached to the loose end of 360" hose.
12. Ensure that none of the hoses contact any sharp edges or hot surfaces. Tie-wrap all hoses securely leaving enough slack for the railgear to function.
13. Fill the hydraulic brake system and bleed the air out:
 - a) Fill the hydraulic brake pump tank with **ESSO Univis Extra** (or equivalent) hydraulic fluid.
 - b) Turn on the dash switch. Depress and hold the vehicle brake pedal. The hydraulic brake pump should start.
 - c) Open the air bleed valve on each brake cylinder to allow air to escape.
 - d) Close the air bleed valve on each brake cylinder.
 - e) Release the brake pedal.
 - f) Re-fill the hydraulic brake pump tank with hydraulic fluid.
 - g) Repeat the above steps until only oil and no more air comes out of the air bleed valve.
 - h) Fill the hydraulic brake pump tank to the fill line.
14. Follow the Hydraulic Brake Relief Valve Setting procedure detailed in the Operation, Service and Parts section of this manual.
15. Follow the Brake Shoe To Rail Wheel Clearance Adjustment procedure detailed in the Operation, Service and Parts section of this manual.
16. Test the operation of the hydraulic brakes as per the Operation, Service and Parts section of this manual.



G&B Specialties, Inc.

A Global Railway Industries Company



MIO-B46RXR20229 (Rev A)

ITEM	PART No.	DESCRIPTION OF ITEM(PART)	QTY.
1	R-20229D	BRAKE ASSY, DRIVERS SIDE	1
2	R-20229P	BRAKE ASSY, PASSENGERS SIDE	1
3	R-20231R-A	MTG BRKT, BRAKE ASSY, RHS	1
4	R-20231L-A	MTG BRKT, BRAKE ASSY, LHS	1
5	H.H.C.S.	1/2" UNC GR.8 x 1.50" Lg.	16
6	F WASHER	1/2" TYPE-A GR.8	32
7	NYLOCK NUT	1/2" UNC, JAM, GR.8	16
8	-	REAR AXLE	REF
9	-	RAILSWEEP	REF
10	H.H.C.S.	1/2" UNC GR.8 x 2.50" Lg.	4
10A	H.H.C.S.	1/2" UNC GR.8 x 2.25" Lg.	4
11	F WASHER	1/2" TYPE-A GR.8	16
12	NYLOCK NUT	1/2" UNC GR.8	8
13	R-20164R	MTG BRKT, BRAKE ASSY, RHS	1
14	R-20164L	MTG BRKT, BRAKE ASSY, LHS	1

REV	CHANGE	DATE	BY	APPD
A	DRAWING RELEASED	12/4/09	AML	

DRIVERS SIDE SHOWN
PASSENGERS SIDE TYPICAL

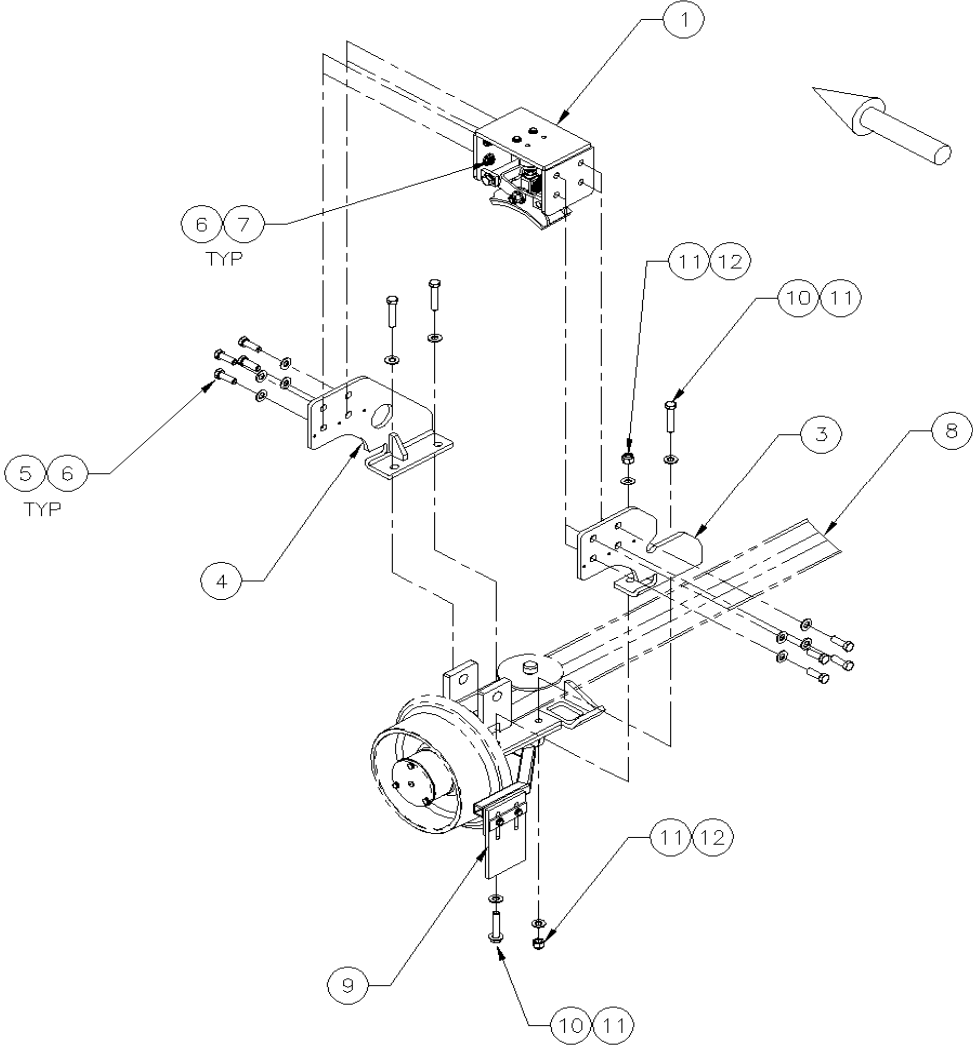

TOLERANCE ON FINISHED DIMENSIONS UNLESS OTHERWISE SPECIFIED		R.M.S. FINISH MAX 125° EXCEPT AS NOTED	
BASIC DIMENSION	FRACTIONS	DECIMALS	
UP TO 6 INCHES	± 1/64	2 PLACE	3 PLACE
ABOVE 6 TO 24	± 1/32	± .02	± .005
ABOVE 24	± 1/16	± .03	± .010
ANGULAR DIMENSIONS		± .06	± .015
		± 1/2°	

DRAWN AML	G & B SPECIALTIES INC. <small>MANUFACTURER OF QUALITY RAILROAD PRODUCTS BERWICK, PENNSYLVANIA, (570) 752-5901, FAX: (570) 752-6397</small>		
DESIGN ~ ENGINEERING ~ MANUFACTURING	DESCRIPTION: R-450 REAR BRAKE KIT		
APPROVED	DATE DRAWN	SHEET	PART NUMBER
CHECKED	12/4/09	1 of 1	K-B45RXR20229-1
REVISED			REVISION
			a



G&B Specialties, Inc.

A Global Railway Industries Company



MIO-B46RXR20229 (Rev A)

REV /	CHANGE	DATE	BY	APPD
A	DRAWING RELEASED	12/5/09	AML	

ITEM	PART NO.	PART DESCRIPTION	QTY
1	R-5670	HYDRAULIC BRAKE PUMP	REF
2	-	HYDRAULIC BRAKE CYLINDER	REF
3	719-FS0-06-04	REDUCER, 3/8 ORB MALE X 1/4 ORB FEMALE	1
4	845-FS0-04-04	TEE, 1/4 ORB X 1/4 JIC	1
5	844-FS-04-04	TEE, 1/4 ORB X 1/4 JIC	1
6	HFS2-04	HYDRAULIC HOSE X 36"	1
7	HFS2-04	HYDRAULIC HOSE X 84"	1
8	HFS2-04	HYDRAULIC HOSE X 360"	1
9	HU04-04NJ	COUPLING	4*
10	HU04-04MF	COUPLING	2*

INSTALLED ON HOSES

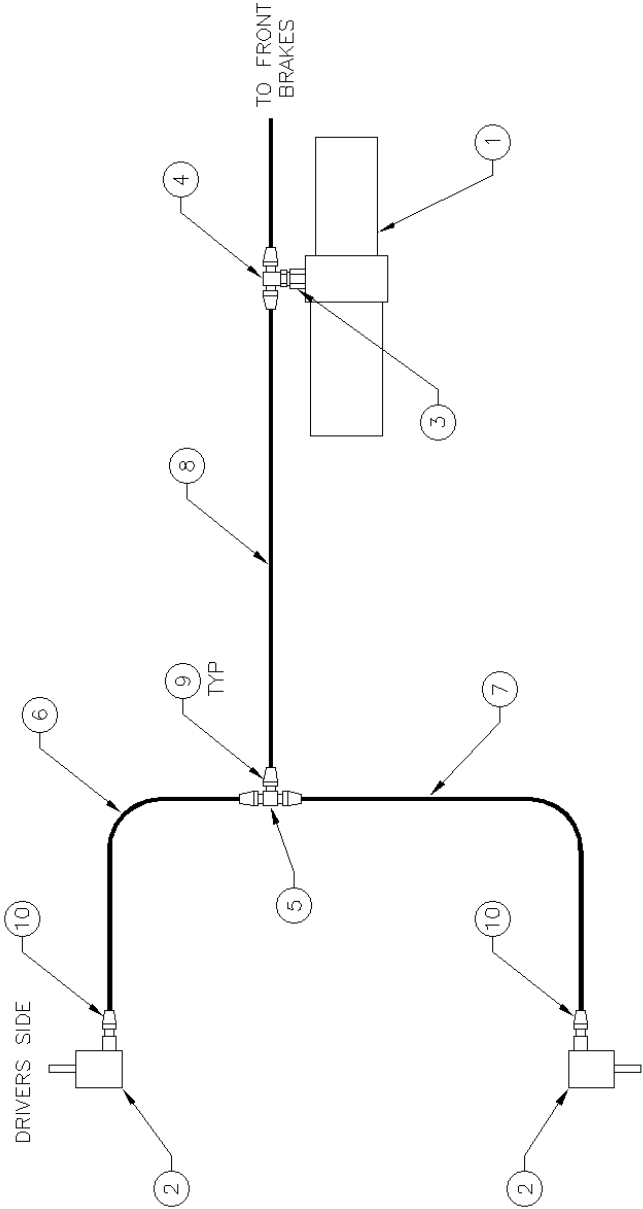

G & B SPECIALTIES INC. MANUFACTURER OF QUALITY RAILROAD PRODUCTS BERWICK, PA, USA TEL: (570) 752-5901 FAX: (570) 752-6397	
DESIGN - ENGINEERING - MANUFACTURING THIS DOCUMENT AND THE DRAWINGS AND THE PRODUCTS IT PURCHASES ARE THE PROPERTY OF G&B SPECIALTIES INC. AND ARE TO BE USED ONLY IN CONNECTION WITH THE PRODUCTS AND SERVICES PROVIDED BY G&B SPECIALTIES INC. ANY REPRODUCTION OR USE OF THIS DOCUMENT WITHOUT THE EXPRESS WRITTEN CONSENT OF G&B SPECIALTIES INC. IS STRICTLY PROHIBITED.	
DRAWING NUMBER: K-B45RXP20229-2 PART NUMBER: 1 REVISION: A	CHECKED: AML APPROVED: AML DATE: 12/5/09

DIMENSION	TOLERANCE ON FINISHED DIMENSIONS UNLESS OTHERWISE SPECIFIED	
	FRACTIONS	DECIMALS
UP TO 6 INCHES	± 1/64	± .02
6 TO 24 INCHES	± 1/32	± .03
ABOVE 24 INCHES	± 1/16	± .06
ANGULAR DIMENSIONS	± 1/2°	



OPERATION, SERVICE AND PARTS OF REAR HYDRAULIC BRAKE KIT

SAFETY PRECAUTIONS

If any operating, service or parts problems are encountered, please call G&B Specialties, Inc. for technical assistance.



- **Failure to heed to any of the following warnings could result in severe bodily injury and/or equipment damage.**
- **Read and understand this manual completely before attempting operation of the railgear-equipped vehicle.**
- **Operating instructions provided below only address the Rafna railgear equipment. Applicable railway company procedures and policies must be adhered to.**
- **Railway company rules governing rail travel must be observed at all times.**
- **Before performing any work under the vehicle or railgear, ensure the engine is turned off and the parking brake is set.**
- **Ensure all body parts and loose clothing are clear of any moving parts of the railgear. Be aware of all pinch points.**
- **Despite the added braking power provided by the railgear air brakes, braking distance while on rail is greater than when on road.**
- **Never operate the vehicle if the Gross Vehicle Weight Rating (GVWR), Gross Axle Weight Rating Front or Rear (GAWR), or the wheel or tire load ratings are exceeded.**
- **Do not use regular brake fluid in the rear hydraulic brake system, as it will damage the hydraulic brake pump and the brake cylinders.**



OPERATION OF REAR HYDRAULIC BRAKE KIT

With the rear hydraulic brake kit installed on this vehicle, it may be operated as normal, however the hydraulic brake pump must be turned “Off” during road travel and “On” during rail travel. The rear hydraulic brake kit provides additional braking power when on rail. Braking distance on rail is much greater than when on road and will be adversely affected by inclement weather.

Never operate the vehicle if the Gross Vehicle Weight Rating (GVWR), Gross Axle Weight Rating Front or Rear (GAWR), or the wheel or tire load ratings are exceeded.

A dash switch is provided to turn off the power to the hydraulic brake pump, which prevents the railgear brakes from functioning during road travel. When travelling on rail, with the dash switch in the “On” position, the railgear hydraulic brakes act together with the vehicle’s brakes to provide added braking power through the rail wheels.

To Operate The Vehicle On Rail:

1. Turn the “Railgear Brake Pump” dash switch to the “On” position.
2. Proceed with rail travel. The railgear hydraulic brakes will function with the vehicle brakes when the vehicle brake pedal is depressed.

To Operate The Vehicle On Road:

1. Turn the “Railgear Brake Pump” dash switch to the “Off” position.
2. Proceed with road travel. The railgear hydraulic brakes will remain in-active.



SERVICE OF REAR HYDRAULIC BRAKE KIT

The rear hydraulic brake kit must be serviced regularly to avoid damage to the equipment. Table 1 below provides the Recommended Service Schedule and the detailed service procedures follow.

Do not torque the 1/2” fasteners that pass through the brake shoe linkage. These fasteners must remain slightly loose to allow the hydraulic brakes to function freely. Table 2 provides all other Standard Fastener Torque Values.

Table 1: Recommended Service Schedule

Service Required	Initial 100 km (62 Miles) of road and/or rail use	Monthly	6 Months	Yearly
Inspect hydraulic brake kit fasteners (re-torque if required)	✓		✓	✓
Inspect all hydraulic fittings and hoses for leaks and wear	✓		✓	✓
Check oil in hydraulic reservoir (fill if required)	✓	✓		✓
Check / adjust brake shoe to rail wheel clearance (see procedure)	✓		✓	✓

Table 2: Standard Fastener Torque Values

Fastener Size	Fastener Torque Value (ft-lbs) Dry
1” UNC Gr. 8 Fasteners	250
3/4” UNC Gr. 8 Fasteners	175
5/8” UNC Gr. 8 Fasteners	150
1/2” UNC Gr. 8 Fasteners	100
3/8” UNC Gr. 8 Fasteners	40
1/4” UNC Gr. 8 Fasteners	12



BRAKE SHOE TO RAIL WHEEL CLEARANCE ADJUSTMENT

The clearance between the brake shoe and the rail wheel must be correctly adjusted to prevent brake drag and to ensure proper braking ability. Check and adjust the brake shoe to rail wheel clearance as follows:

1. With the hydraulic brake dash switch turned “Off” and the railgear hydraulic brakes in the retracted position, visually inspect the railgear hydraulic brake components for excessive damage and/or wear and measure the brake shoe to rail wheel clearance.

Acceptable Brake Shoe To Rail Wheel Clearance	1/8” – 1/4”
--	--------------------

2. If the brake shoe to rail wheel clearance is not within specifications, adjust as follows:
 - Loosen the jam nut above the clevis on the clevis push rod.
 - Turn the clevis push rod to adjust the clevis up to increase the clearance or down to decrease the clearance.
 - When moving the clevis down on the clevis push rod, do not move the clevis down beyond the point at which the inside bottom face of the clevis is flush with the end of the push rod. Replace the brake shoe and re-adjust.
 - Tighten the jam nut above the clevis on the clevis push rod.
3. Re-check the brake shoe to rail wheel clearance and re-adjust as necessary.



HYDRAULIC BRAKE RELIEF VALVE SETTING

The hydraulic brake pump is equipped with one relief valve located on the hydraulic pump body. This relief valve protects the entire hydraulic brake system from over pressurization. The relief valve will require adjustment at installation and if ever there appears to be inadequate hydraulic pressure to operate the hydraulic brakes or if the rail wheels are found to skid when the brakes are applied.

1. Disconnect the hydraulic hose from the pump.
2. Install a hydraulic pressure gauge (up to 3000 PSI) between the disconnected hydraulic hose and the pump port. The pressure gauge will indicate the relief valve setting when the pump is loaded.
3. Turn the “Railgear Brake Pump” dash switch to the “On” position and depress the vehicle brake pedal so that activating the brakes creates a load on the pump. The pressure reading on the pressure gauge should climb to 700 PSI.
4. If the pressure is not correct, release the brake pedal and adjust the relief valve on the pump accordingly. Loosen the lock nut and turn the setscrew in to increase the pressure or out to decrease the pressure. Re-check the pressure.
5. Once the correct pressure on the pump relief valve is obtained, ensure that the lock nut on the relief valve is tightened. Release the pressure in the system and remove the pressure gauge. Re-connect the hydraulic hose.
6. Ensure that the hydraulic hoses are connected properly and that the hydraulic brakes are functioning properly.



MIO-B46RXR20229 (Rev A)

PARTS OF REAR HYDRAULIC BRAKE KIT

ITEM	PART No.	DESCRIPTION OF ITEM(PART)	QTY.
1	R-20229D	BRAKE ASSY, DRIVERS SIDE	1
2	R-20229P	BRAKE ASSY, PASSENGERS SIDE	1
3	R-20231R-A	MTG BRKT, BRAKE ASSY, RHS	1
4	R-20231L-A	MTG BRKT, BRAKE ASSY, LHS	1
5	H.H.C.S.	1/2" UNC GR.8 x 1.50" Lg.	16
6	F'WASHER	1/2" TYPE-A GR.8	32
7	NYLOCK NUT	1/2" UNC, JAM, GR.8	16
8	-	REAR AXLE	REF
9	-	RAILSWEEP	REF
10	H.H.C.S.	1/2" UNC GR.8 x 2.50" Lg.	4
10A	H.H.C.S.	1/2" UNC GR.8 x 2.25" Lg.	4
11	F'WASHER	1/2" TYPE-A GR.8	16
12	NYLOCK NUT	1/2" UNC GR.8	8
13	R-20164R	MTG BRKT, BRAKE ASSY, RHS	1
14	R-20164L	MTG BRKT, BRAKE ASSY, LHS	1

REV	CHANGE	DATE	BY	APPD
A	DRAWING RELEASED	12/4/09	AML	

DRIVERS SIDE SHOWN
PASSENGERS SIDE TYPICAL

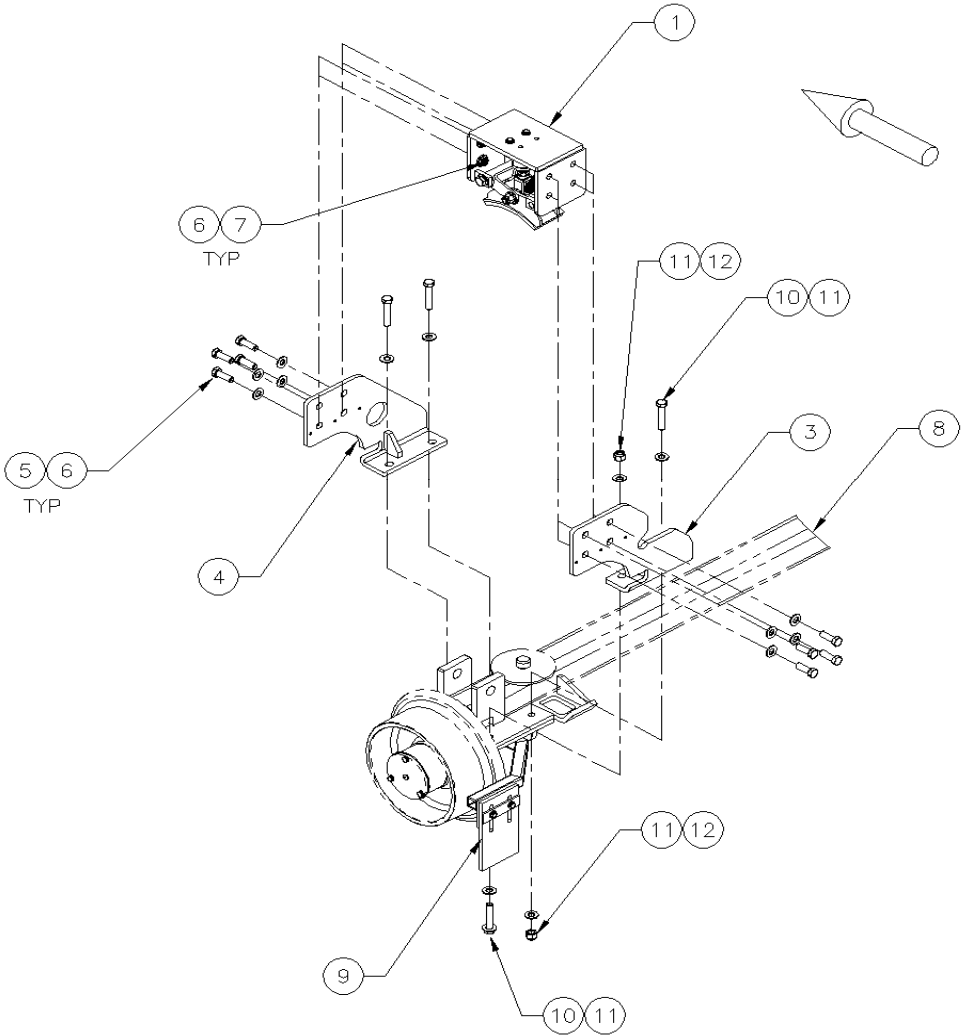

TOLERANCE ON FINISHED DIMENSIONS UNLESS OTHERWISE SPECIFIED		R.M.S. FINISH MAX 125 ^A EXCEPT AS NOTED		DRAWN AML	G & B SPECIALTIES INC. MANUFACTURER OF QUALITY RAILROAD PRODUCTS BERWICK PENNSYLVANIA (570) 752-5901 FAX (570) 752-6397			
BASIC DIMENSION	FRACTIONS	DECIMALS						
UP TO 6 INCHES	± 1/64	2 PLACE	± .005	APPROVED CHECKED DESIGNED ~ ENGINEERING ~ MANUFACTURING G & B SPECIALTIES INC. IS THE OWNER OF THIS DOCUMENT AND ITS CONTENTS AND IS FURNISHED FOR CONSULTATION PURPOSES ONLY. NO RIGHTS ARE TO BE CONSIDERED IN RESPECT TO THIS DOCUMENT REPRODUCED OR DISCLOSED TO OTHERS, EXCEPT WITH WRITTEN CONSENT OF G & B SPECIALTIES INC.	DESCRIPTION: R-450 REAR BRAKE KIT			
ABOVE 6 TO 24	± 1/32	± .03	± .010					
ABOVE 24	± 1/16	± .06	± .015					
ANGULAR DIMENSIONS		± 1/2°		DRAWING NUMBER K-B45RXR20229-1	DATE DRAWN 12/4/09	SHEET 1 of 1	PART NUMBER K-B45RXR20229-1	REVISION a



G&B Specialties, Inc.

A Global Railway Industries Company



MIO-B46RXR20229 (Rev A)

REV	CHANGE	DATE	BY	APPD
A	DRAWING RELEASED	12/5/08	AML	

ITEM	PART NO.	PART DESCRIPTION	QTY
1	R-5670	HYDRAULIC BRAKE PUMP	REF
2	-	HYDRAULIC BRAKE CYLINDER	REF
3	719-FS0-06-04	REDUCER, 3/8 ORB MALE X 1/4 ORB FEMALE	1
4	845-FS0-04-04	TEE, 1/4 ORB X 1/4 JIC	1
5	844-FS-04-04	TEE, 1/4 ORB X 1/4 JIC	1
6	HFS2-04	HYDRAULIC HOSE X 36"	1
7	HFS2-04	HYDRAULIC HOSE X 84"	1
8	HFS2-04	HYDRAULIC HOSE X 360"	1
9	HU04-04NJ	COUPLING	4*
10	HU04-04MF	COUPLING	2*

INSTALLED ON HOSES

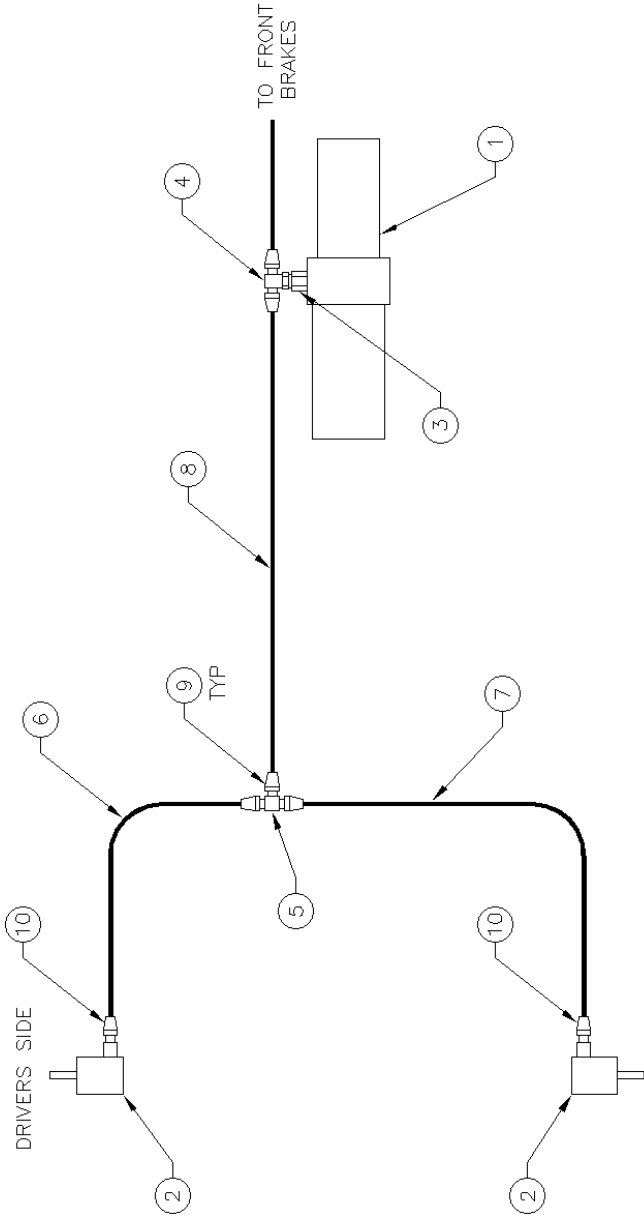

G & B SPECIALTIES INC. 535 WEST 3 RD STREET, BERWICK, PA, USA 17004 TEL: (570) 752-5901 FAX: (570) 752-6397																							
DESIGN ~ ENGINEERING ~ MANUFACTURING G & B SPECIALTIES INC. IS THE OWNER OF THIS DOCUMENT. NO PARTS OR SERVICES ARE TO BE REPRODUCED OR USED IN ANY MANNER WITHOUT THE WRITTEN CONSENT OF G & B SPECIALTIES INC.																							
<table border="1"> <tr> <th colspan="2">TOLERANCE ON FINISHED DIMENSIONS UNLESS OTHERWISE SPECIFIED</th> </tr> <tr> <th>BASIC DIMENSION</th> <th>DECIMALS</th> </tr> <tr> <td>6 INCHES AND BELOW</td> <td>± .015</td> </tr> <tr> <td>ABOVE 6 TO 24</td> <td>± .010</td> </tr> <tr> <td>ABOVE 24</td> <td>± .015</td> </tr> <tr> <th colspan="2">ANGULAR DIMENSIONS</th> </tr> <tr> <td></td> <td>± 1/2°</td> </tr> </table>	TOLERANCE ON FINISHED DIMENSIONS UNLESS OTHERWISE SPECIFIED		BASIC DIMENSION	DECIMALS	6 INCHES AND BELOW	± .015	ABOVE 6 TO 24	± .010	ABOVE 24	± .015	ANGULAR DIMENSIONS			± 1/2°	<table border="1"> <tr> <td>REV</td> <td>DATE</td> <td>BY</td> <td>APPD</td> </tr> <tr> <td>A</td> <td>12/5/08</td> <td>AML</td> <td></td> </tr> </table>	REV	DATE	BY	APPD	A	12/5/08	AML	
TOLERANCE ON FINISHED DIMENSIONS UNLESS OTHERWISE SPECIFIED																							
BASIC DIMENSION	DECIMALS																						
6 INCHES AND BELOW	± .015																						
ABOVE 6 TO 24	± .010																						
ABOVE 24	± .015																						
ANGULAR DIMENSIONS																							
	± 1/2°																						
REV	DATE	BY	APPD																				
A	12/5/08	AML																					
K-B45RXR20229-2 1 of 1 K-B45RXR20229-2 A																							



G&B Specialties, Inc.

A Global Railway Industries Company



MIO-B46RXR20229 (Rev A)

BILL OF MATERIAL/PARTS LIST			
ITEM	QTY	PART NUMBER	DESCRIPTION
1	1	R-20250	BRAKE HOUSING
2	1	R-5603	HYDRAULIC CYLINDER
3	1	R-5602	PUSH ROD
4	1	R-4554	BRAKE SHOE
5	1	R-5604	SPRING
6	1	R-4557	BRAKE SHOE LINNAGE
7	1	R-5601	YOKE
8	1	HEX LOCK NUT	1/2" UNC GR.8
9	2	FWASHER	1/4" TYPE-A GR.8
10	2	H.H.C.S.	1/4" UNC GR.8 x 1.25" Lg.
11	2	NYLOCK NUT	1/2" UNC GR.8
12	4	FWASHER	1/2" TYPE-A GR.8
13	1	H.H.C.S.	1/2" UNC GR.8 x 3.50"
14	1	H.H.C.S.	1/2" UNC GR.8 x 4.50"
15	12	NYLOCK NUT	1/4" UNC GR.8

NOTES:

- ASSEMBLE AS SHOWN
- DRIVERS SIDE SHOWN, PASSENGERS SIDE OPPOSITE

REVISED ITEM #1	10/30/09	DATE	BT	APPRO
ISSUING ENGINEER				
CHANGE				
REVISION				

G & B SPECIALTIES INC.	
DESIGN - ENGINEERING - MANUFACTURING	
RAILWAY EQUIPMENT	
1000 W. 3 RD STREET, BERWICK, PA 17004-2507	
TEL: (570) 752-5901 FAX: (570) 752-6397	
WWW.GANDBSPECIALTIES.COM	

REVISED ITEM #1	10/30/09	DATE	BT	APPRO
ISSUING ENGINEER				
CHANGE				
REVISION				

REVISED ITEM #1	10/30/09	DATE	BT	APPRO
ISSUING ENGINEER				
CHANGE				
REVISION				

REVISED ITEM #1	10/30/09	DATE	BT	APPRO
ISSUING ENGINEER				
CHANGE				
REVISION				