



OPERATION, SERVICE AND PARTS OF HYDRAULIC KIT

SAFETY PRECAUTIONS

If any operating, service or parts problems are encountered, please call G&B Specialties, Inc. for technical assistance.



- Failure to heed to any of the following warnings could result in severe bodily injury and/or equipment damage.
- Read and understand this manual completely before attempting operation of the railgear equipped vehicle.
- Operating instructions provided below only address the Rafna Industries railgear equipment. Applicable railway company procedures and policies must be adhered to.
- Railway company rules governing rail travel must be observed at all times.
- Before performing any work under the vehicle or railgear, ensure the engine is turned off and the parking brake is set.
- Ensure all body parts and loose clothing are clear of any moving parts of the railgear. Be aware of all pinch points.
- The In-Cab Controls can only be used for removing the vehicle from rail. DO NOT use the In-Cab Controls to place the vehicle on rail as this may cause damage to the railgear.
- Note that if the railgear is part way retracted or extended, opening the manifold directional valve manual over-rides may cause the railgear to drop suddenly causing personal injury. Ensure all body parts are clear of the railgear if it should suddenly drop.
- When operating the railgear using the emergency hand pump, ensure that the correct manual valve over-ride is open for the desired railgear (front or rear) and desired direction of operation (raise or lower).
- Do not use the emergency hand pump to raise and lower the railgear on a routine basis. If the hydraulic pump or manifold should fail, have it repaired as soon as possible.
- If the emergency hand pump has been used to raise or lower the railgear, ensure the manifold directional valve manual over-rides are in the closed and locked position before starting road or rail travel.



- **Ensure the hydraulic pump has been de-energized before starting road or rail travel.**
- **Never operate the vehicle if the Gross Vehicle Weight Rating (GVWR), Gross Axle Weight Rating Front or Rear (GAWR), or the wheel or tire load ratings are exceeded.**

OPERATION OF HYDRAULIC KIT

With the hydraulic kit installed on this vehicle, it may be operated as normal.

Never operate the vehicle if the Gross Vehicle Weight Rating (GVWR), Gross Axle Weight Rating Front or Rear (GAWR), or the wheel or tire load ratings are exceeded.

Refer to the Railgear Kit Operation, Service and Parts manual for information on the mechanical operation, service and parts of the railgear.

Location And Operation Of The Railgear Hydraulic System Controls:

The railgear hydraulic system consists of a hydraulic pump and manifold, a front control box, a rear control box, and an in-cab control panel.

1. The railgear hydraulic pump must be energized prior to use by turning on the respective dash switch on the control panel in the vehicle cab. At this point the dash switch light should come on but the pump should not run and the railgear should not move until a control button is depressed.
2. The direction of the front or rear railgear movement is selected by pushing the “Up” or “Down” button on the respective control box located near the railgear. At this point the pump should start and the railgear should move in the selected direction.
3. The direction of the front or rear railgear movement can also be selected by pushing the “Up” or “Down” button on the respective in-cab control panel switch. At this point the pump should start and the railgear should move in the selected direction. Note that the in-cab controls can only be used to raise the railgear from rail to road position.
4. To stop the movement of the railgear, release the depressed button.
5. The pump must be de-energized after use by turning off the respective dash switch. At this point the pump should not be able to run and the control buttons should be in-active.



Location And Operation Of The Hydraulic Pump Emergency Hand Pump:

If the railgear hydraulic system should fail such that the railgear does not respond to depressing the buttons on the front and / or rear control boxes, then the emergency hand pump system may be used to place the vehicle on rail or remove the vehicle from rail. Follow the standard operation procedure (as detailed in the Railgear Kit Operation, Service and Parts Manual) except substitute the following steps when the procedure requires raising or lowering of the railgear.

1. Remove the hand pump handle from storage and insert the handle into the hand pump located on the body of the hydraulic pump.
2. There are four manifold directional valves, one for each railgear function: “Front Gear Up”, “Front Gear Down”, “Rear Gear Up”, and “Rear Gear Down”. The manual over-rides for these valves are located on the manifold under rubber boots. Only open one manifold directional valve over-ride at a time. To manually open a manifold directional valve over-ride, remove the rubber boot, push in and twist the knob allowing the knob to extend. To manually close a manifold directional valve over-ride, push the knob in, twist the knob to lock it in place and replace the rubber boot.
3. Select and open the manual over-ride for the respective railgear and desired direction of movement.
4. Remove the locking cable holding collar from storage. It can be slipped in between the locking cable handle and the locking cable bulkhead fitting to hold the locking cable in the disengaged position.
5. Pump the emergency hand pump handle to move the railgear. It will require 30 to 50 full strokes to fully raise or lower each railgear.
6. Close the manual over-ride. Ensure all manifold directional valve manual over-rides are closed and locked in position. Replace all the rubber boots.
7. Remove and store the locking cable holding collar and the hand pump handle.
8. Ensure the railgear lock pins are fully engaged as required by the procedure.



SERVICE OF HYDRAULIC KIT

The hydraulic kit must be serviced regularly to avoid damage to the equipment. Table 1 below provides the Recommended Service Schedule and Table 2 provides Standard Fastener Torque Values.

The recommended oil for the railgear hydraulic system is ESSO Univis Extra or equivalent. In extremely cold weather areas/seasons, ESSO Univis J13 or equivalent may be used.

Table 1: Recommended Service Schedule

Service Required	Initial 100 km (62 Miles) of road and/or rail use	Daily	Weekly	Monthly
Inspect hydraulic kit fasteners (re-torque if required)		✓	✓	✓
Inspect all hydraulic fittings and hoses for leaks and wear.		✓	✓	✓
Check oil in hydraulic reservoir. (fill with railgear raised if req'd)				✓
Check emergency hand pump and manifold over-ride operation				✓

Table 2: Standard Fastener Torque Values

Fastener Size	Fastener Torque Value (ft-lbs) Dry
1" UNC Gr. 8 Fasteners	250
3/4" UNC Gr. 8 Fasteners	175
5/8" UNC Gr. 8 Fasteners	150
1/2" UNC Gr. 8 Fasteners	100
3/8" UNC Gr. 8 Fasteners	40
1/4" UNC Gr. 8 Fasteners	12



HYDRAULIC SYSTEM RELIEF VALVE SETTING

This system is equipped with one relief valve located on the railgear pump body next to the emergency hand pump. This relief valve protects the entire hydraulic system from over pressurization. The relief valve will require adjustment at installation and if ever there appears to be inadequate hydraulic pressure to operate the railgear.

1. Disconnect the hydraulic hose from the “P” port of the pump.
2. Install a hydraulic pressure gauge (up to 3000 PSI) between the disconnected hydraulic hose and the pump port. The pressure gauge will indicate the relief valve setting when the pump is loaded.
3. Following the procedure in the Railgear Kit Operation, Service and Parts manual, raise the front railgear completely and continue to raise the railgear so that the hydraulic cylinder creates a load on the pump by trying to “dead-head”. The pressure reading on the pressure gauge should climb to 1800 PSI.
4. If the pressure is not correct, release the railgear controls and adjust the relief valve on the pump accordingly. Loosen the lock nut and turn the setscrew in to increase the pressure or out to decrease the pressure. Re-check the pressure.
5. Once the correct pressure on the pump relief valve is obtained, ensure the lock nut on the relief valve is tightened. Release the pressure in the system and remove the pressure gauge. Re-connect all hydraulic hoses.
6. Ensure the railgear is properly raised as per the Railgear Kit Operation, Service and Parts manual.



ELECTRICAL SYSTEM TROUBLESHOOTING

The following basic test can be performed to check the integrity of the railgear electrical system.

Should the railgear pump fail to operate, first check the fuse or the circuit breaker and all wiring for shorts. Then the following test can be performed to verify the integrity of the pump motor and pump solenoid.

1. Pump motor test:
 - a) Connect one end of a 4 gauge shunt wire to the pump motor power terminal and touch the other end to the battery positive terminal.
 - b) The pump motor should run upon touching the shunt wire.
 - c) If the pump does not run, the pump is not properly grounded or the pump motor is defective.
 - d) If the pump motor runs, test for a defective solenoid.
2. Solenoid test:
 - a) Connect one end of a 14 gauge shunt wire to the switching terminal on the solenoid and touch the other end to the battery positive terminal. If the pump does not operate the solenoid is not properly grounded or it is defective. If the pump operates, the problem lies with the fuse/circuit breaker, wiring and/or switches.

Should the pump start running immediately following turning on the respective dash switch, the following tests can be performed to help locate the problem.

1. Disconnect the wire from the switching terminal on the solenoid. If the pump continues to run, then the solenoid is defective.
2. Check all wiring and switches for shorts and / or loose terminals.



PARTS OF RAILGEAR KIT

ITEM	PART NO.	DESCRIPTION	QTY	ITEM	PART NO.	DESCRIPTION	QTY
1	R-048	HYDRAULIC PUMP & MANIFOLD	1	11	-	1/4" LOCK WASHER	4
2	R-2688	LOCKING CABLE HOLDING COLLAR	1	12	-	1/4" SAE WASHER	4
3	R-2979	LOCK CABLE & CONTROL BRACKET (NOT SHOWN)	1	13	-	5/16" UNC GR. 8 BOLT X 0.75" LONG	4
4	CO-130N	"FRONT GEAR UP" DECAL	1	14	-	5/16" LOCK WASHER	4
5	CO-130O	"REAR GEAR UP" DECAL	1	15	-	5/16" SAE WASHER	4
6	CO-130P	"FRONT GEAR DOWN" DECAL	1	16	-	8-32 MACH. SCREW X 0.75" LONG ZINC PLATED (NOT SHOWN)	2
7	CO-130Q	"REAR GEAR DOWN" DECAL	1	17	-	8-32 UNC ZINC PLATED NYLOCK NUT (NOT SHOWN)	2
8	S-001031	RAILGEAR OPERATION DECAL (NOT SHOWN)	2	18	-	FRONT BUMPER EXTENSION (AS PER MOUNTING KIT)	N/A
9	R-2961	IN-CAB CONTROL LOCK CAM CONVERTER	2	19	-	RAILGEAR LOCK CABLE (AS PER RAILGEAR KIT)	N/A
10	-	1/4" UNC GR. 8 BOLT X 0.75" LONG	4	20	-	RAILGEAR LOWER CROSS FRAME (AS PER RAILGEAR KIT)	N/A

RAFNA INDUSTRIES LTD.
19300 CLARK-GRAHAM
BAIE D'URFEE, QUEBEC
(514) 457-4373

DESCRIPTION: HYDRAULIC KIT
REFERENCE: HYDRAULIC KIT PARTS
MATERIAL: -
P/N: K-H29RRFR0482OR DATE: APR/22/04
DRAWN: MER APPR: -
DIM: INCHES SCALE: 1:1
SHEET: 1 OF 6 DWG#K-H29RRFR0482OR

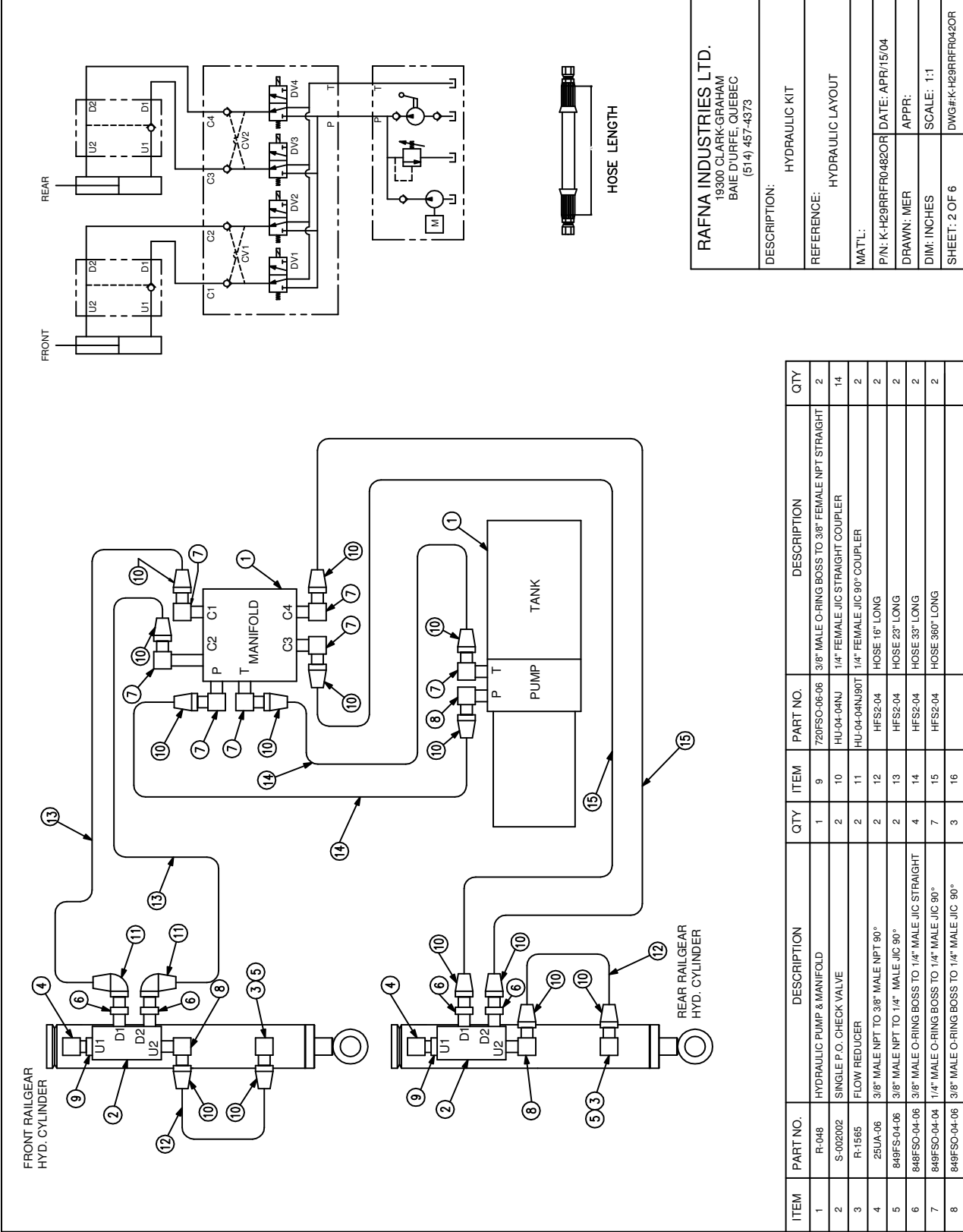

RAFNA INDUSTRIES LTD. 19300 CLARK-GRAHAM BAIE D'URFÉ, QUÉBEC (514) 457-4373
DESCRIPTION: HYDRAULIC KIT
REFERENCE: HYDRAULIC LAYOUT
MAT'L:
P/N: K-H29RRFR0482OR DATE: APR/15/04
DRAWN: MER APPR:
DIM: INCHES SCALE: 1:1
SHEET: 2 OF 6 DWG#K-H29RRFR042OR

ITEM	PART NO.	DESCRIPTION	QTY	ITEM	PART NO.	DESCRIPTION	QTY
1	R-048	HYDRAULIC PUMP & MANIFOLD	1	9	720FSO-06-06	3/8" MALE O-RING BOSS TO 3/8" FEMALE NPT STRAIGHT	2
2	S-002002	SINGLE P.O. CHECK VALVE	2	10	HU-04-04NJ	1/4" FEMALE JIC STRAIGHT COUPLER	14
3	R-1565	FLOW REDUCER	2	11	HU-04-04NJ90T	1/4" FEMALE JIC 90° COUPLER	2
4	25UA-06	3/8" MALE NPT TO 1/4" MALE NPT 90°	2	12	HFS2-04	HOSE 16" LONG	2
5	849FSO-04-06	3/8" MALE NPT TO 1/4" MALE JIC 90°	2	13	HFS2-04	HOSE 23" LONG	2
6	848FSO-04-06	3/8" MALE O-RING BOSS TO 1/4" MALE JIC STRAIGHT	4	14	HFS2-04	HOSE 33" LONG	2
7	849FSO-04-04	1/4" MALE O-RING BOSS TO 1/4" MALE JIC 90°	7	15	HFS2-04	HOSE 360" LONG	2
8	849FSO-04-06	3/8" MALE O-RING BOSS TO 1/4" MALE JIC 90°	3	16			

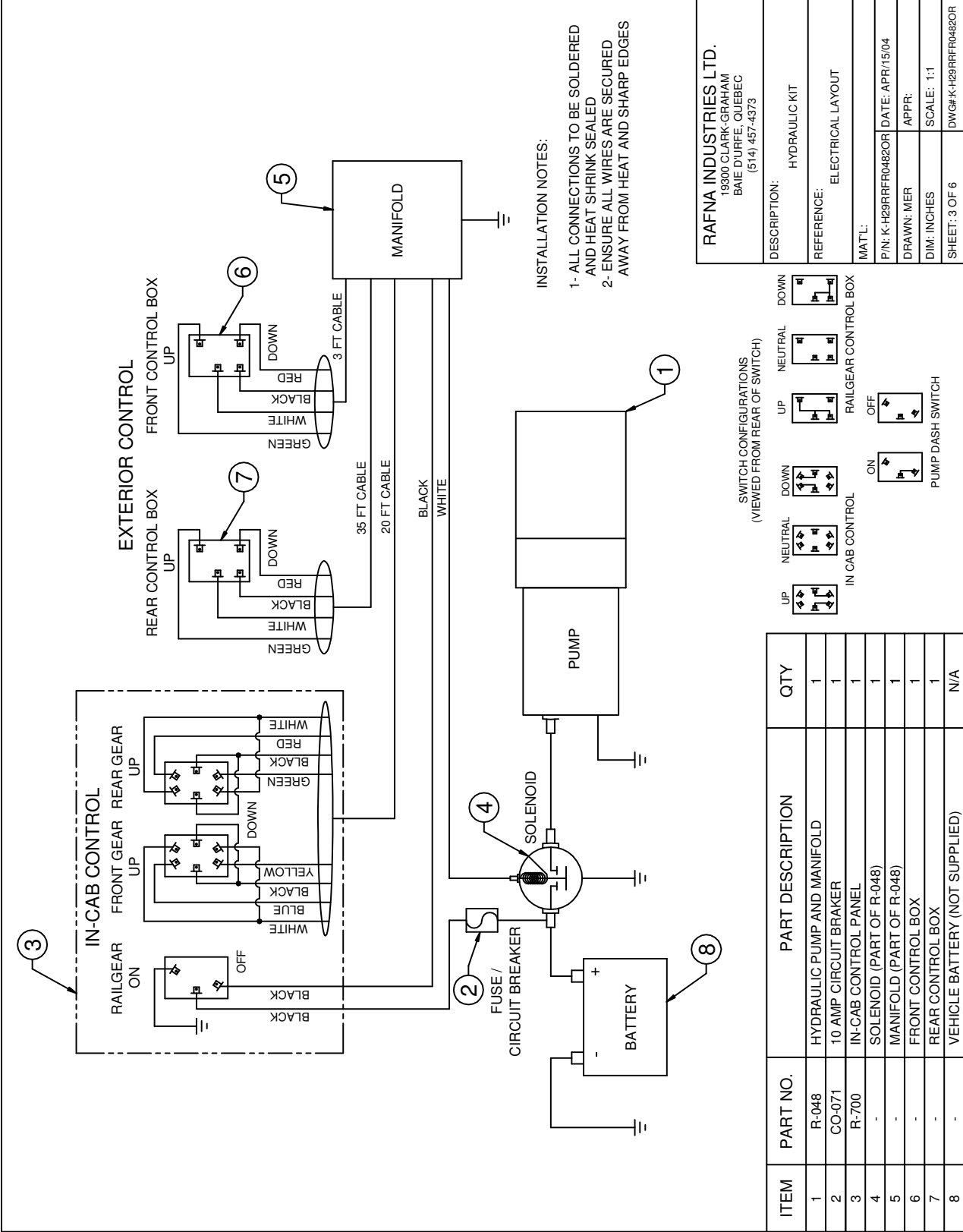

RAFNA INDUSTRIES LTD. 19300 CLARK-GRAHAM BAIE D'URFE, QUEBEC (514) 457-4373	
DESCRIPTION:	HYDRAULIC KIT
REFERENCE:	ELECTRICAL LAYOUT
MAT'L:	
P/N: K-H29RRFR0482OR	DATE: APR/15/04
DRAWN: MER	APPR:
DIM: INCHES	SCALE: 1:1
SHEET: 3 OF 6	DWG#K-H29RRFR0482OR

ITEM	PART NO.	PART DESCRIPTION	QTY
1	R-048	HYDRAULIC PUMP AND MANIFOLD	1
2	CO-071	10 AMP CIRCUIT BREAKER	1
3	R-700	IN-CAB CONTROL PANEL	1
4	-	SOLENOID (PART OF R-048)	1
5	-	MANIFOLD (PART OF R-048)	1
6	-	FRONT CONTROL BOX	1
7	-	REAR CONTROL BOX	1
8	-	VEHICLE BATTERY (NOT SUPPLIED)	N/A

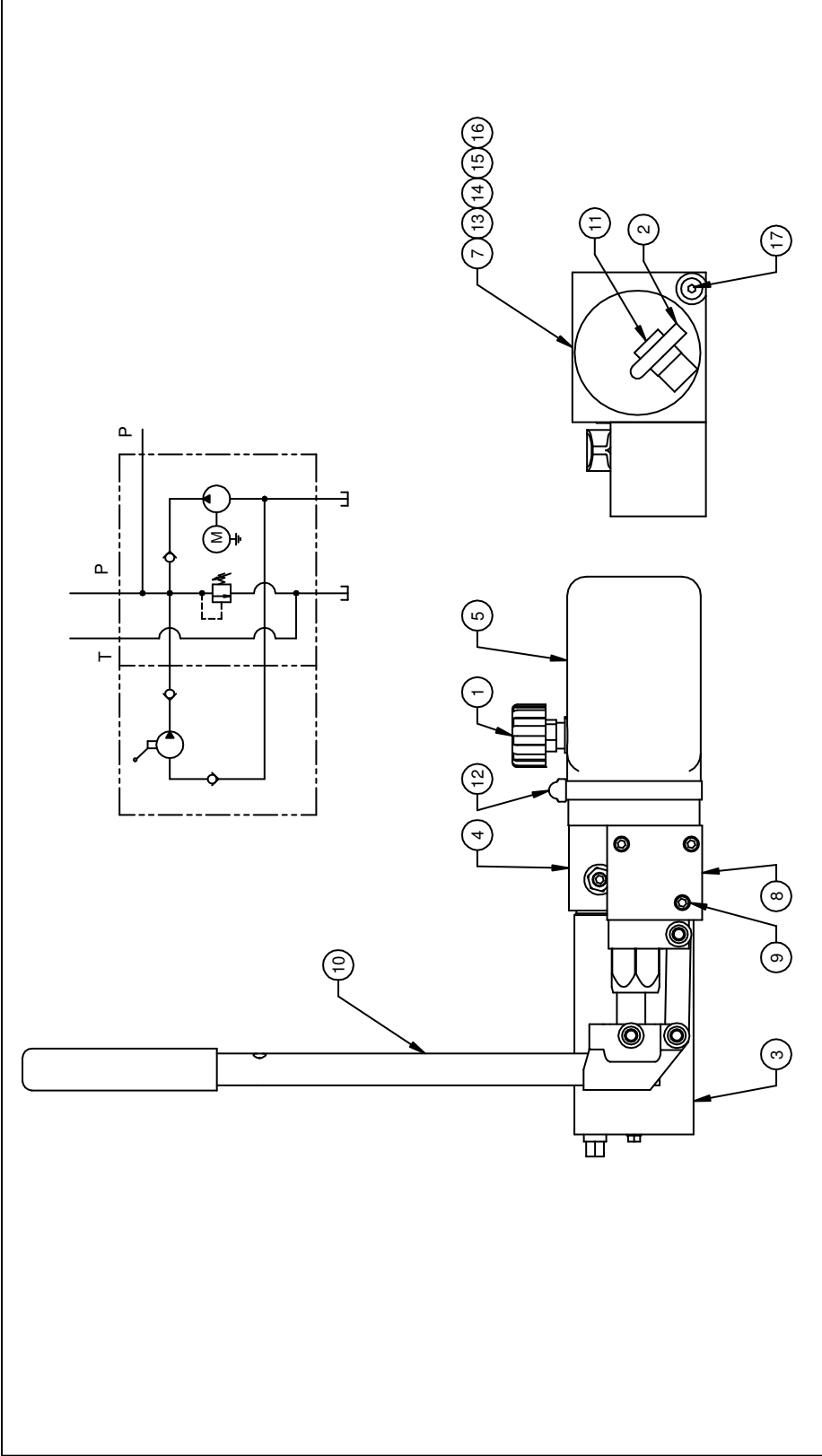

RAFNA INDUSTRIES LTD. 19300 CLARK-GRAHAM BAIE D'URFE, QUEBEC (514) 457-4373
DESCRIPTION: HYDRAULIC KIT
REFERENCE: PUMP PARTS
MAT'L:
P/N: K-H29RRFR0482OR DATE: APR/15/04
DRAWN: MER APPR:
DIM: INCHES SCALE: 1:1
SHEET: 4 OF 6 DWG#K-H29RRFR0482OR

ITEM	PART NO.	PART DESCRIPTION	QTY	ITEM	PART NO.	PART DESCRIPTION	QTY
1	S-003001	BREATHER	1	15	S-003015	SPRING	1
2	S-003002	SUCTION ELBOW	1	16	S-003016	SPRING RETAINER	1
3	S-003003	MOTOR	1	17	S-003017	SAE 04 O-RING PLUG	1
4	S-003004	M254 MINI PUMP	1	18	S-003018	O-RING (NOT SHOWN - AT HAND PUMP MOUNT)	2
5	S-003005	PLASTIC RESERVOIR 6.5" LONG	1	19	S-003030	SOLENOID (NOT SHOWN)	1
6	S-003006	1/8" PIPE PLUG (NOT SHOWN - TANK PLUG)	1	20	S-003031	TERMINAL BOOT (NOT SHOWN)	1
7	S-003007	SAE 06 O-RING PLUG	1	21	S-003032	INTERMEDIATE SHAFT (NOT SHOWN)	1
8	S-003008	HAND PUMP BODY	1	22	S-003033	1/4" UNC SHSC SCREW X 1.25 LONG (NOT SHOWN)	1
9	S-003009	HAND PUMP MOUNTING SCREW	3	23	S-003034	0.056 CU - IN/REV MICRO PUMP (NOT SHOWN)	1
10	S-003010	PUMP HANDLE	1	24	S-003035	1/16" X 2-1/4" X 2.375" O-RING SEAL (NOT SHOWN)	1
11	S-003011	RETURN TUBE	1	25	S-003036	1/4" DOWELL PIN X 1.25" LONG (NOT SHOWN)	1
12	S-003012	RESERVOIR CLAMP	1	26	S-003037	1/16" X 1/2" X 5/8" O-RING SEAL (NOT SHOWN)	1
13	S-003013	BALL	1	27	S-003038	1/16" X 3/4" X 3.13" O-RING SEAL (NOT SHOWN)	1
14	S-003014	BALL FOLLOWER	1	28	S-003041	PUMP ASSEMBLY COMPLETE AS SHOWN	1

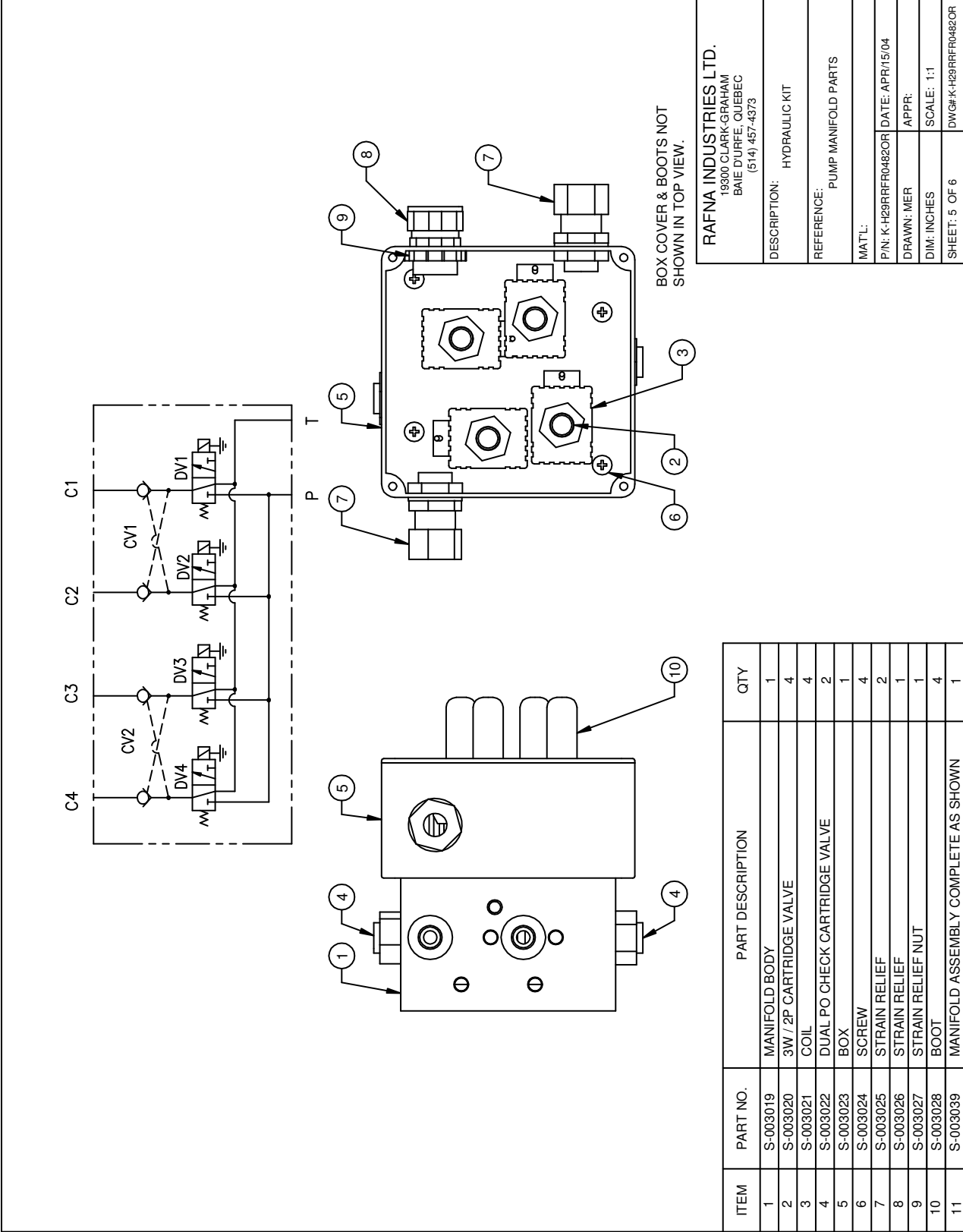

RAFNA INDUSTRIES LTD. 19300 CLARK-GRAHAM BAIE D'URFE, QUEBEC (514) 457-4373	
DESCRIPTION:	HYDRAULIC KIT
REFERENCE:	PUMP MANIFOLD PARTS
MAT'L:	
P/N: K-H29RRFR0482OR	DATE: APR/15/04
DRAWN: MER	APPR:
DIM: INCHES	SCALE: 1:1
SHEET: 5 OF 6	DWG#K-H29RRFR0482OR

ITEM	PART NO.	PART DESCRIPTION	QTY
1	S-003019	MANIFOLD BODY	1
2	S-003020	3W / 2P CARTRIDGE VALVE	4
3	S-003021	COIL	4
4	S-003022	DUAL PO CHECK CARTRIDGE VALVE	2
5	S-003023	BOX	1
6	S-003024	SCREW	4
7	S-003025	STRAIN RELIEF	2
8	S-003026	STRAIN RELIEF	1
9	S-003027	STRAIN RELIEF NUT	1
10	S-003028	BOOT	4
11	S-003039	MANIFOLD ASSEMBLY COMPLETE AS SHOWN	1

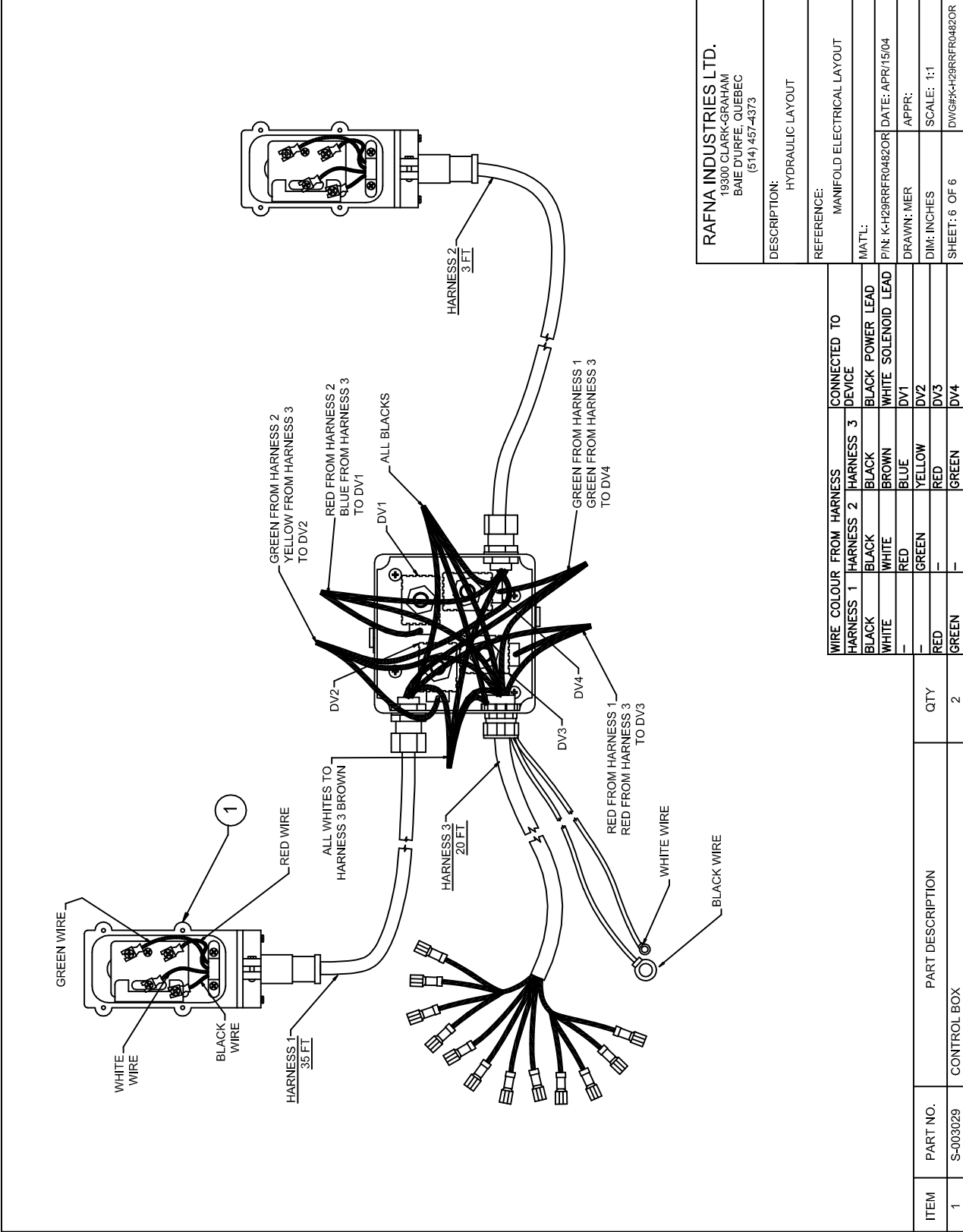

RAFNA INDUSTRIES LTD. 19300 CLARK-SRAHAM BAIE D'URFE, QUEBEC (514) 457-4373	
DESCRIPTION:	HYDRAULIC LAYOUT
REFERENCE:	MANIFOLD ELECTRICAL LAYOUT
MAT'L:	
P/N: K-H29RRFR0482OR	DATE: APR/15/04
DRAWN: MER	APPR:
DIM: INCHES	SCALE: 1:1
SHEET: 6 OF 6	DWG#K-H29RRFR0482OR

WIRE COLOUR FROM HARNESS	CONNECTED TO DEVICE
HARNESS 1	HARNESS 3
BLACK	BLACK POWER LEAD
WHITE	WHITE SOLENOID LEAD
BROWN	DV1
BLUE	DV2
YELLOW	DV3
RED	DV4
GREEN	

ITEM	PART NO.	PART DESCRIPTION	QTY
1	S-003029	CONTROL BOX	2