

INSTALLATION OF R-290 FRONT MOUNTING KIT 2008-2016 FORD F-250/350 4X4 DIESEL

INSTALLATION SAFETY PRECAUTIONS

If any installation problems are encountered, please call G&B Specialties, Inc. for technical assistance before continuing with the installation process.



- Failure to heed to any of the following warnings could result in severe bodily injury and/or equipment damage.
- Read and understand this manual completely before attempting installation of the equipment.
- Installation instructions provided below only address the RAFNA railgear equipment. Applicable railway company procedures and policies must be adhered to.
- Before performing any work under the vehicle or railgear, ensure the engine is turned off and the parking brake is set.
- Do not start the vehicle with the power steering hoses disconnected. Reconnect all hoses and secure the power steering cooler if the vehicle is started.
- Ensure all removed components are given to the vehicle owner after the installation of the railgear. These components must be re-installed if the railgear is removed from the vehicle.
- Always disconnect the vehicle's battery when welding on the vehicle or railgear to protect the vehicle's electrical system.
- Railway Company rules governing rail travel must be observed at all times.
- Never operate the vehicle if the Gross Vehicle Weight Rating (GVWR), Gross Axle Weight Rating Front or Rear (GAWR), or the wheel or tire load ratings are exceeded.

INSTALLATION OF FRONT MOUNTING KIT

The following procedure details the installation of the front mounting kit. The hardware required for this installation is listed in the table below.

Front Mounting Kit Installation Parts

Part Number	Description	Qty
R-13145D	Mounting Bracket - Drivers Side	1
R-13145P	Mounting Bracket - Passengers Side	1
R-12009-C	Frame Extension - Drivers Side	2
R-11111	Bumper Spacer - 5"	4
R-11112	Tow Hook Spacer, 1/2"	2
R-11113	Tow Hook Spacer, 1"	2
R-11109	Frame Spacer	2
R-11106B	Frame Spacer	4
R-11127	Railgear Mounting Shim - 1/8"	2
R-11128	Railgear Mounting Shim - 1/4"	4
R-990KIT-220	3/4" UNC GR.8 Bolt x 2.00" Lg.	4
	3/4" UNC GR.8 Bolt x 2.75" Lg.	4
	3/4" Flat Washer, GR.8 - Type-A	8
	3/4" UNC GR.8 Nylon Insert Lock Nut	4
	5/8" UNC GR.8 Bolt x 5.50" Lg.	3
	5/8" UNC GR.8 Bolt x 6.00" Lg.	5
	5/8" Flat Washer, GR.8 - Type-A	16
	5/8" UNC GR.8 Nylon Insert Lock Nut	8
	1/2" UNC GR.8 Bolt X 2.50" Lg.	6
	1/2" UNC GR.8 Bolt X 3.00" Lg.	6
	1/2" UNC GR.8 Bolt X 3.50" Lg.	6
	1/2" UNC GR.8 Bolt X 1.50" Lg.	8
	1/2" Flat Washer, GR.8 - Type-A	22
	1/2" UNC GR.8 Nylon Insert Lock Nut	8
R-990KIT-410	7/16" UNC GR.8 Bolt X 1.50" Lg.	2
	7/16" UNC GR.8 Bolt X 2.50" Lg.	6
	7/16" UNC GR.8 Bolt X 3.00" Lg.	6
	7/16" UNC GR.8 Bolt X 3.50" Lg.	6
	7/16" UNC GR.8 Nylon Insert Lock Nut	8
	7/16" Flat Washer, GR.8 - Type-A	16
R-051	Side Wand Set	1
R-14529D	Hole Template - Drivers Side	1
R-14529P	Hole Template - Passengers Side	1

Frame Modification (Figures 1, 1A, 1B & 2, 2A)

1. Remove the front bumper and front tow hooks if so equipped. Remove the coolant line retaining clips from the inside passenger frame rail. The coolant line retaining clip will need to be relocated in an appropriate place by the installer.
 - a.) Remove Front Compatibility brackets from front frame horns.
Applies to 2010-2016 Model Year
2. Retain the front bumper and tow hooks for re-installation.
3. On the out-board side of the driver's side frame rail, drill out the first existing hole to 11/16" diameter. Drill this hole thru to the in-board side of the frame and thru the in-board frame rail.
4. On the out-board side of the passenger's side frame rail, drill out the first existing hole to 11/16" diameter. Drill this hole thru to the in-board side of the frame and thru the in-board frame rail.
5. Drill the existing three holes in the top of the drivers and passengers frame rail to 9/16" diameter.

If the frame extensions supplied with this kit do not have nuts welded to the inside then it will not be necessary to complete step #5

6. Insert frame extension into frame and align with first drilled hole in the frame and with the drilled holes in the top of the frame. Attach the frame extension to the frame using a 1/2" X 1-1/2" bolt and flat washer inserted thru one of the holes drilled in the top of the truck frame and into the frame extension - tighten but do not torque at this time (this is to hold the frame extension in place for marking and drilling the frame for the remaining holes). There are 1/2" lock nuts welded to the inside of the frame extension. Make sure that the top of the frame extension is tight up against the inside top surface of the truck frame. Repeat for passengers' side. Figures 2 & 3
 - **Use only if the frame extension supplied with this truck does not have the nuts welded to the inside otherwise continue to step #7**

Insert frame extension into frame and align with first drilled hole in the frame and with the drilled holes in the top of the frame. Attach the frame extension to the frame using a 7/16" X 1-1/2" bolt, flat washer and nut inserted thru one of the holes in the top of the truck frame and thru the frame extension - tighten but do not torque at this time (this is to hold the frame extension in place for marking and drilling the frame for the remaining holes). Make sure that the top of the frame extension is tight up against the inside top surface of the truck frame. Repeat for passengers' side. Figures 2A & 3A

7. On the outside of the driver's side frame rail, bolt the drivers side hole template to the frame extension and truck frame using 5/8" hardware as shown in **Figure 2 or 2A**. The hole template should be level with the top of the frame extension, not the truck frame, and flush with the front of the frame extension. Using a 1/4" center punch, mark the truck frame for the remaining hole using the hole in the template as a guide. Remove the hole template and frame extension from the truck.
8. On the outside of the passenger's side frame rail, bolt the passengers side hole template to the frame extension and truck frame using 5/8" hardware as shown in **Figure 3 or 3A**. The hole template should be level with the top of the frame extension, not the truck frame, and flush with the front of the frame extension. Using a 1/4" center punch, mark the truck frame for the remaining hole using the hole in the template as a guide. Remove the hole template and frame extension from the truck.
9. At the areas on the frame marked in steps 7 & 8, drill an 11/16" diameter hole thru the out-board and in-board frame rails of the drivers and passengers frame rail.

Caution: When drilling thru the driver's side frame rail be sure not to make contact with the radiator or lower radiator hose.

Bracket Assembly - Drivers Side (Figure 4)

1. Assemble the railgear mounting bracket to truck frame and frame extension using 5/8" bolts, flat washers and nylon insert lock nuts. Make sure that the mounting bracket is tight up against the bottom of the frame and frame extension and the inside frame rail. Torque all 5/8" fasteners to 150 ft-lbs dry.
2. Weld the frame extension to the mounting bracket as shown in **Figure 5**.
3. Repeat steps 1 thru 2 for passenger's side.
4. The supplied mounting shims are to be used as required when mounting the railgear to the front mounting brackets.
5. The lower radiator hose clamps on the driver's side may need to be adjusted for proper clearance with the driver's side mounting bracket. (**Figure 6**)

Front Bumper Bracket Mounting (frame extension *with* nuts) (Figure 5)

The OEM truck bumper can be re-installed on the truck using the OEM bumper/tow hook mounting brackets. It will be required to use bumper spacers as show when re-installing the truck bumper. It may also be necessary, but not required, to use the tow hook spacers to raise the OEM bumper for clearance of railgear components, depending on truck ride height. If using spacers, either the 1/2" or 1" spacers but do not use both. Using the tow hook spacers will also limit the amount of bumper trimming required.

1. The OEM bumper/tow hook mounting bracket will need modified for re-installation. The three threaded holes in the bracket will need to be drilled to 17/32" diameter.
2. Remove the 1/2" bolt that is holding the frame extension to the truck frame.

3. If not using spacers, place the OEM bumper mounting bracket on top of the truck frame, align holes and attach to frame/frame extension using 1/2" x 2-1/2" bolts and flat washers. There are 1/2" nuts welded to the inside of the frame extension
4. If using spacers, place either the 1/2" or 1" spacer on top of the frame (not both), place the OEM bumper mounting bracket on top of the spacer, align holes and attach to frame/frame extension using 1/2" bolts and flat washers. There are 1/2" nuts welded to the inside of the frame extension
5. Use the 1/2" x 3" long bolts and flat washers if using the 1/2" spacer or 1/2" x 3-1/2" bolts and flat washers if using the 1" spacer.
6. Torque all 1/2" fasteners to 100 ft-lbs dry.

Front Bumper Bracket Mounting (frame extension without nuts) (Figure 5A)

The OEM truck bumper can be re-installed on the truck using the OEM bumper/tow hook mounting brackets. It will be required to use bumper spacers as shown when re-installing the truck bumper. It may also be necessary, but not required, to use the tow hook spacers to raise the OEM bumper for clearance of railgear components, depending on truck ride height. If using spacers, either the 1/2" or 1" spacers but do not use both. Using the tow hook spacers will also limit the amount of bumper trimming required.

1. The OEM bumper/tow hook mounting bracket will need modified for re-installation. The three threaded holes in the bracket will need to be drilled to 1/2" diameter.
2. Remove the 7/16" bolt that is holding the frame extension to the truck frame.
3. If not using spacers, place the OEM bumper mounting bracket on top of the truck frame, align holes and attach to frame/frame extension using 7/16" x 2-1/2" bolts and hardware.
4. If using spacers, place either the 1/2" or 1" spacer on top of the frame (not both), place the OEM bumper mounting bracket on top of the spacer, align holes and attach to frame/frame extension using 7/16" bolts and hardware.
5. Use the 7/16" x 3" long bolts if using the 1/2" spacer or 1/2" x 3-1/2" bolts if using the 1" spacer.
6. Torque all 7/16" fasteners to 65 ft-lbs dry.

Front Bumper Mounting (Figure 5 & 5A)

1. Attach bumper spacers as shown using 1/2" x 1-1/2" bolts, flat washers and nylon insert lock nuts.
2. Attach OEM bumper to spacers as shown using 1/2" x 1-1/2" bolts, flat washers and nylon insert lock nuts.
3. Torque all 1/2" fasteners to 100 ft-lbs dry.

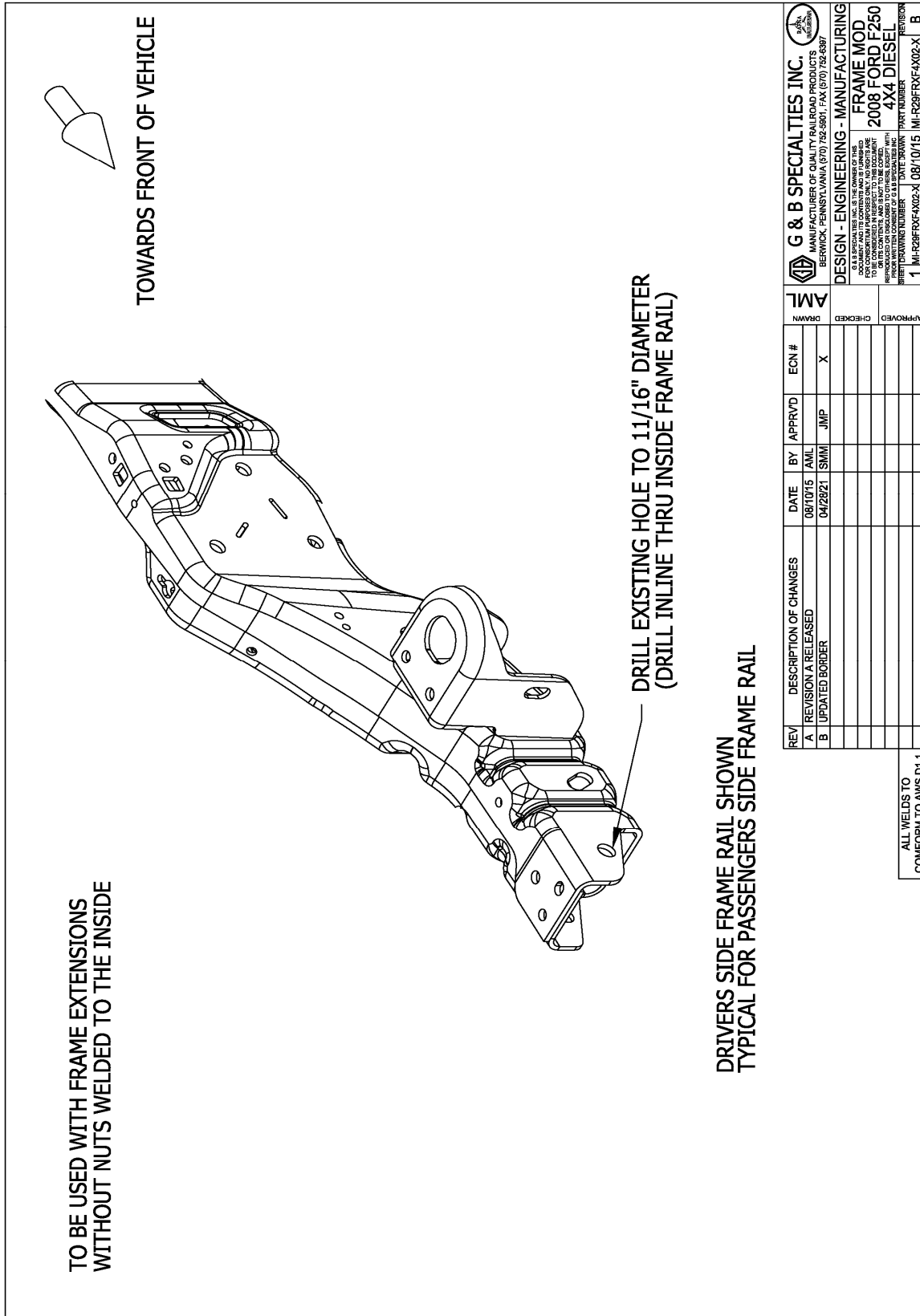

Figure 1B

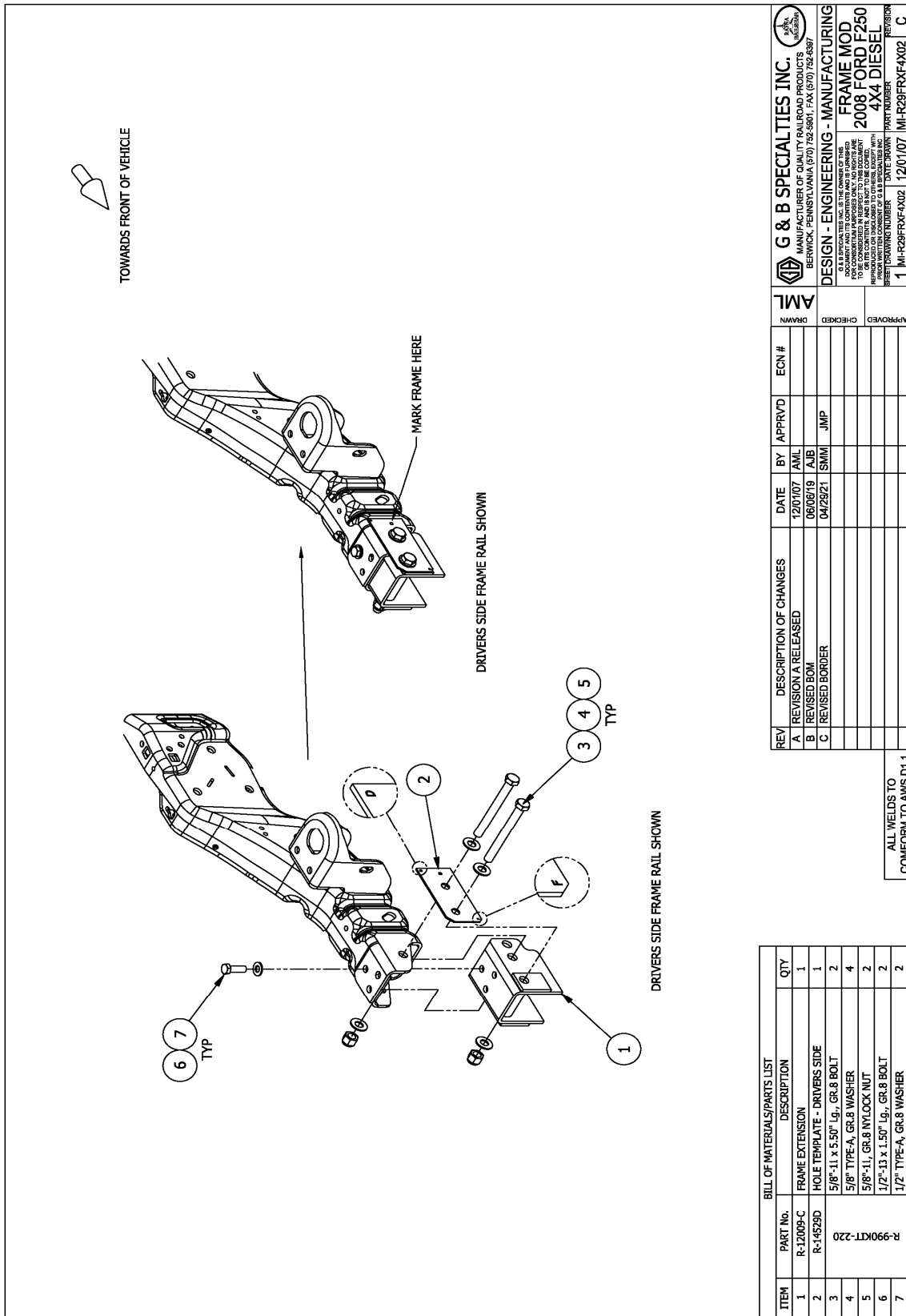

Figure 2

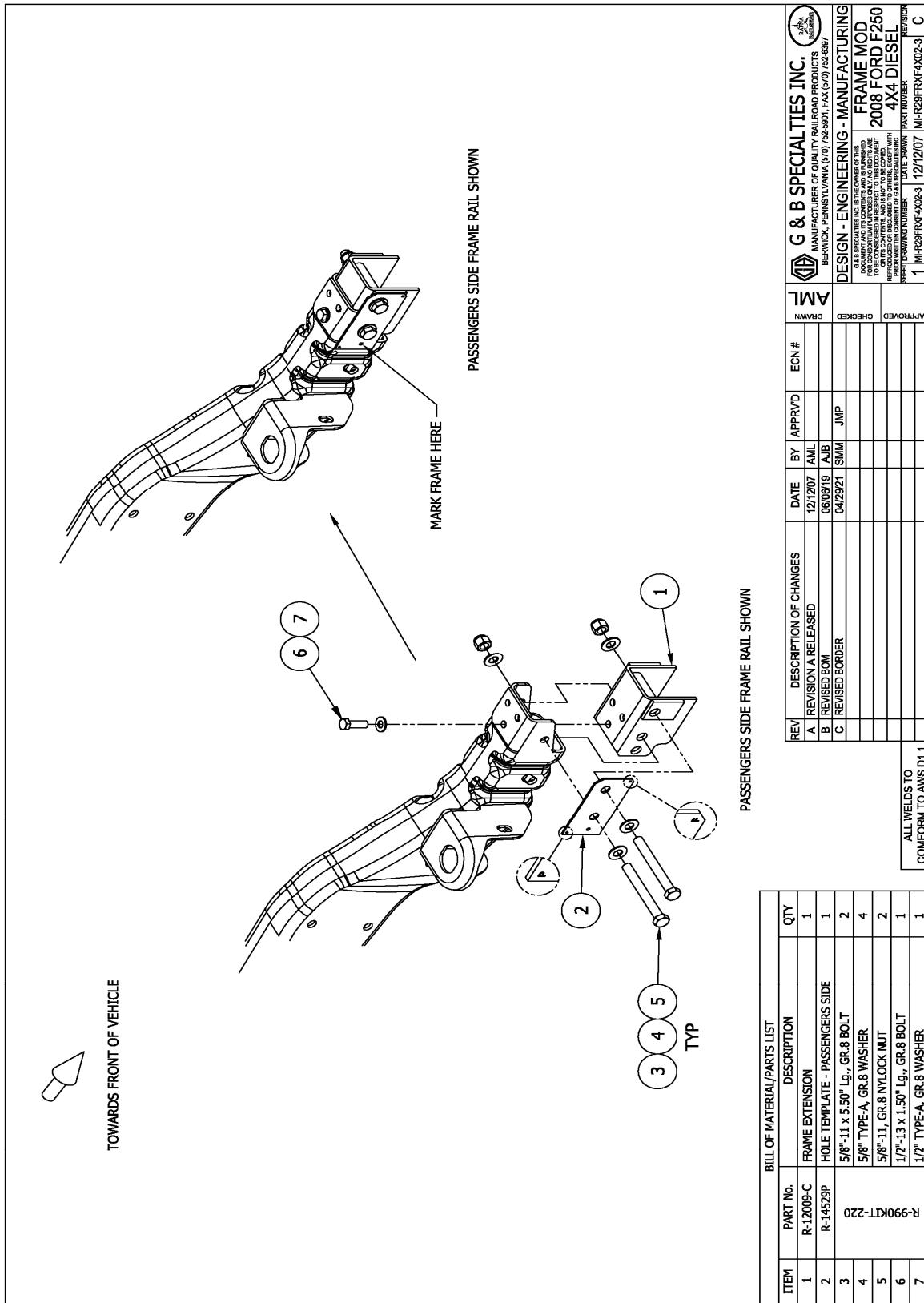

Figure 3

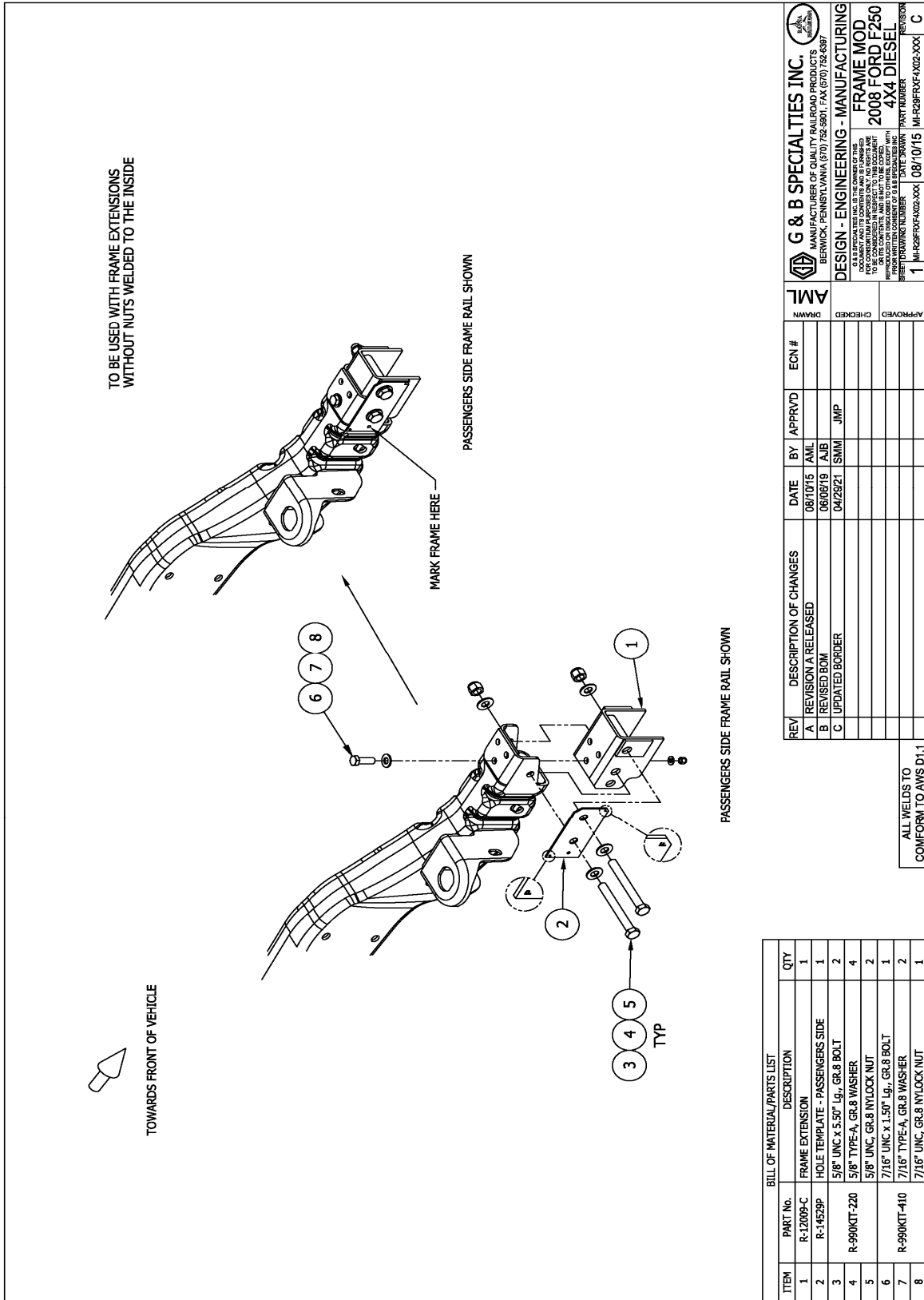

Figure 3A

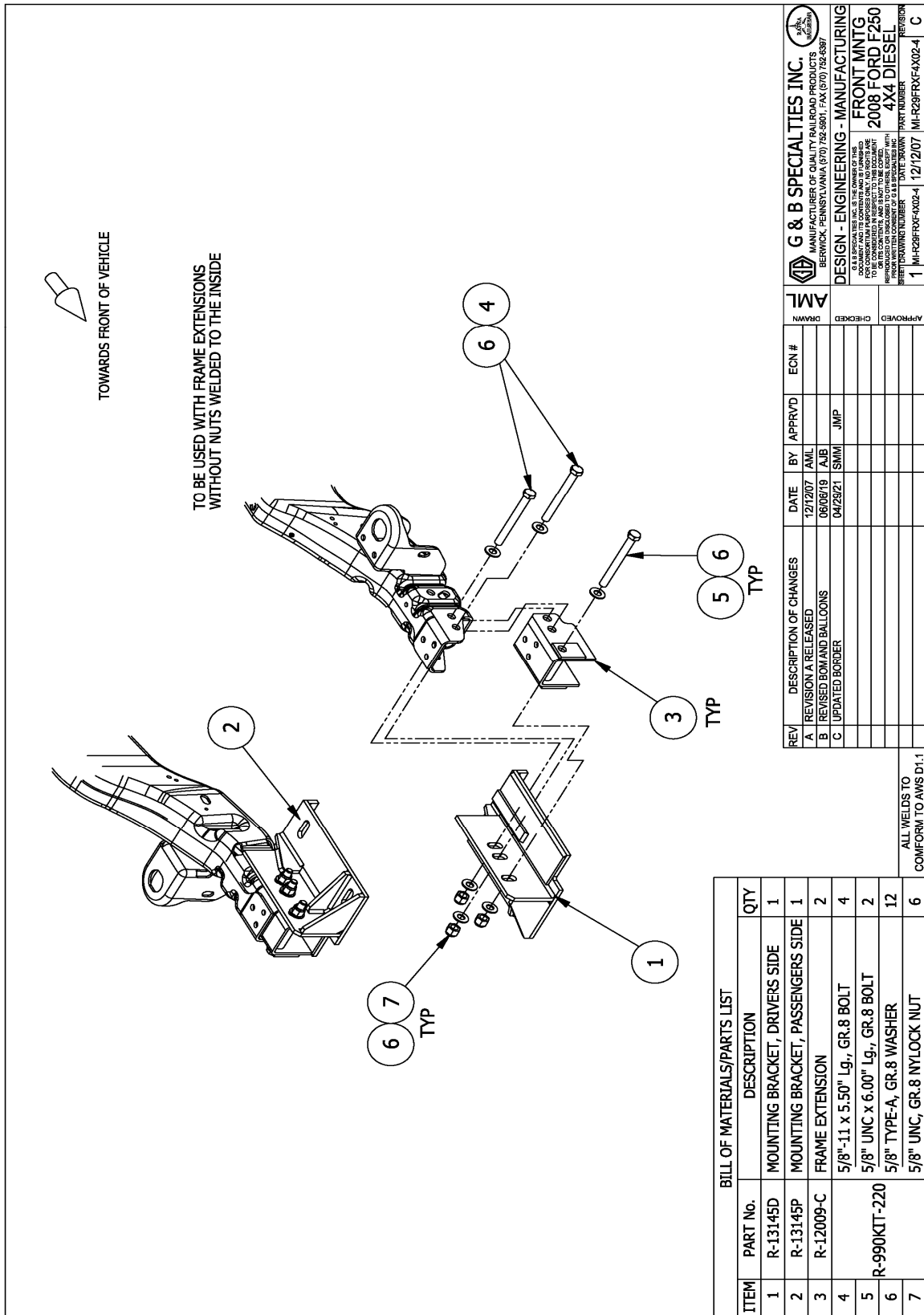

Figure 4

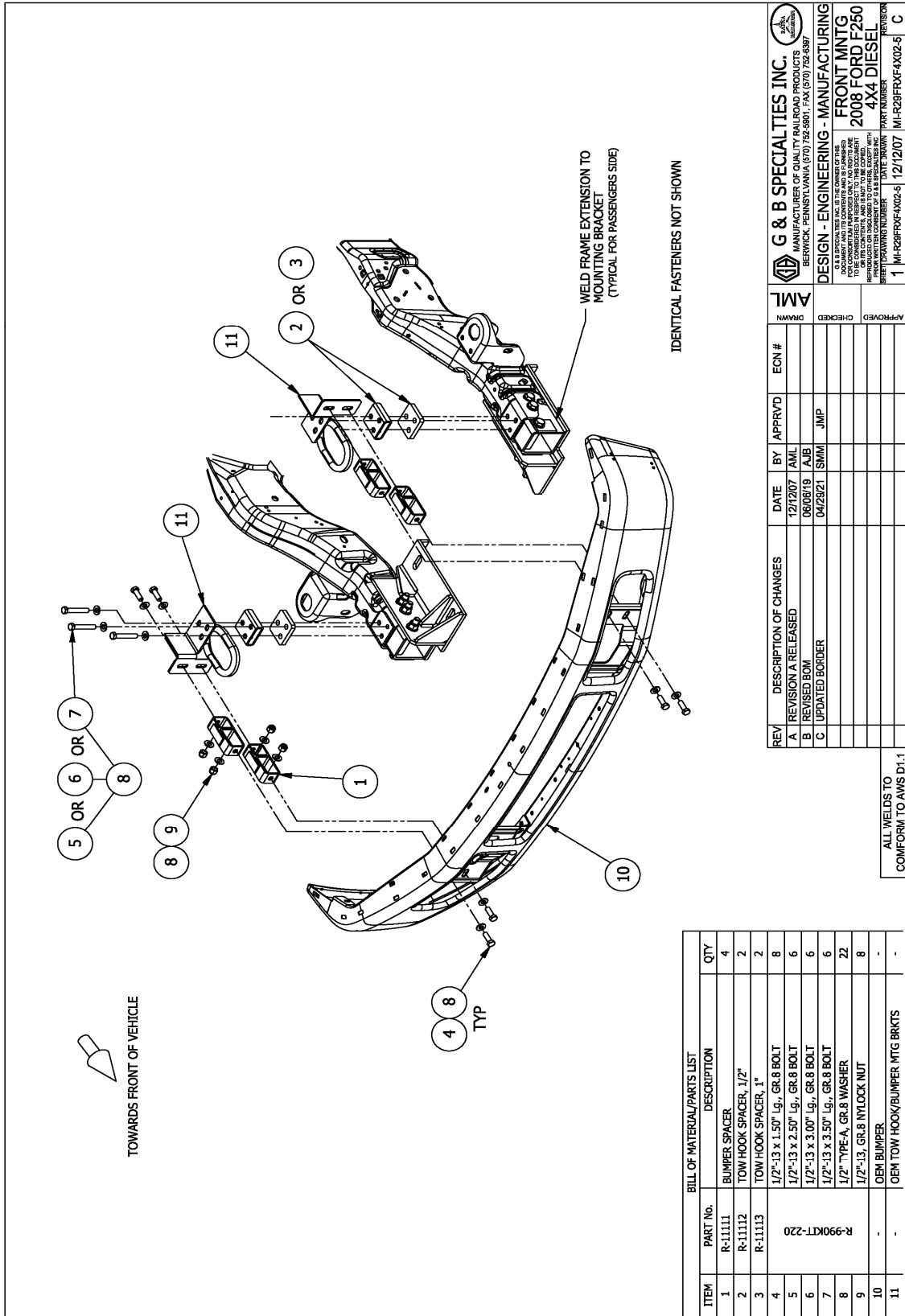

Figure 5

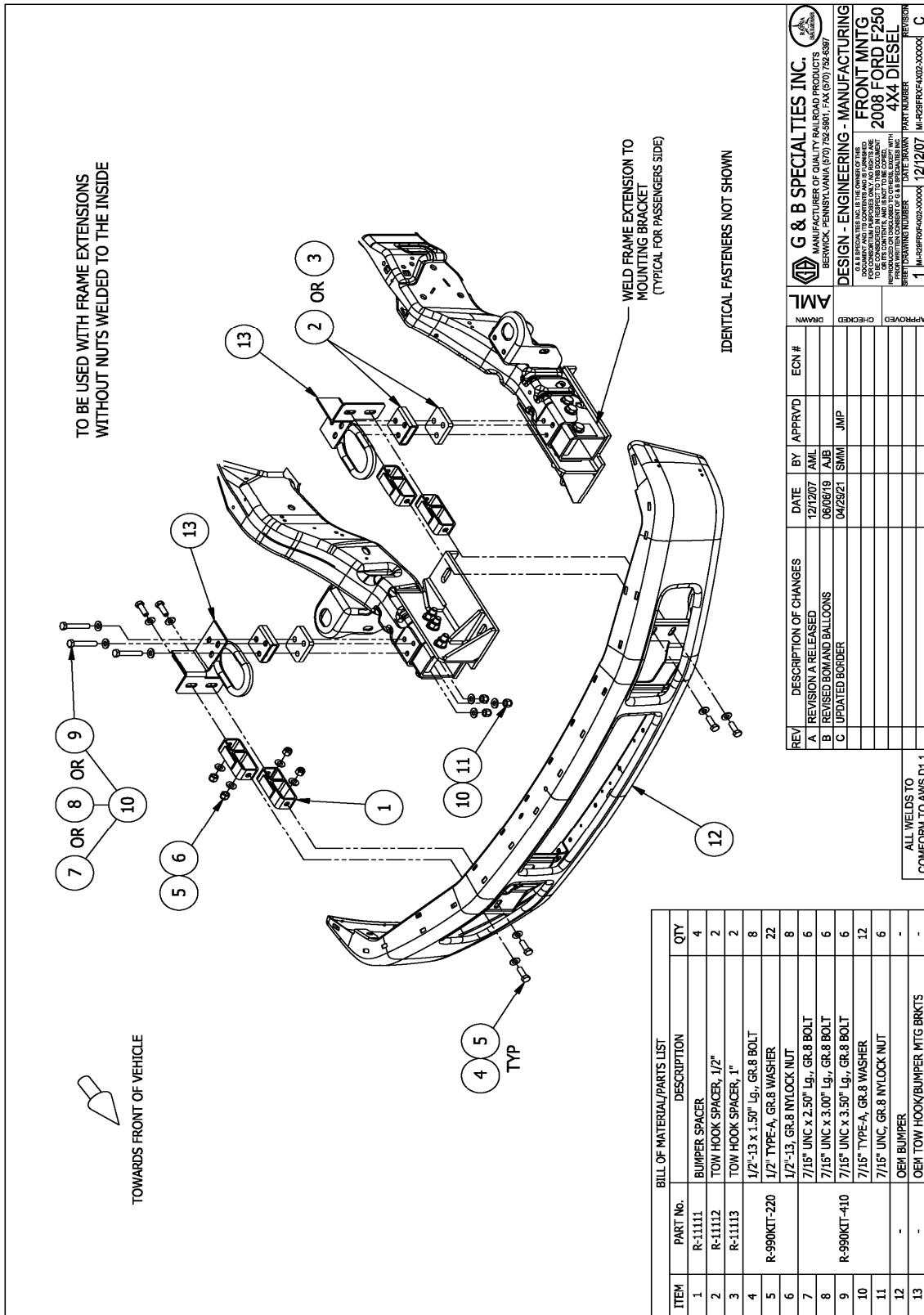

Figure 5A

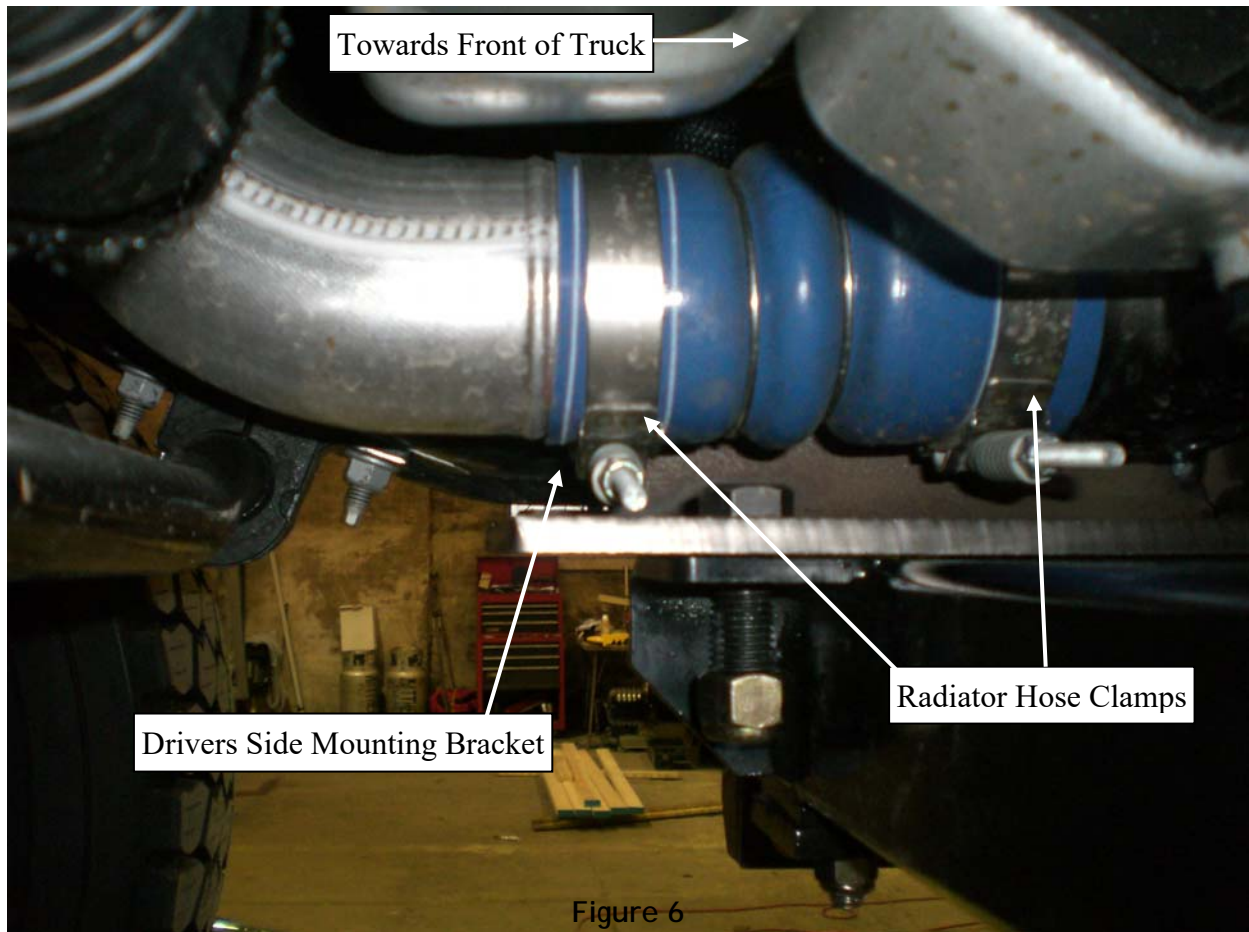

Figure 6

OPERATION, SERVICE AND PARTS OF R-290 FRONT MOUNTING KIT 2008-2016 Ford F-250/350 4x4 Diesel

OPERATION SAFETY PRECAUTIONS

If any operating, services or parts problems are encountered, please call G&B Specialties, Inc. for technical assistance.



- Failure to heed to any of the following warnings could result in severe bodily injury and/or equipment damage.
- Read and understand this manual completely before attempting operation of the railgear equipped vehicle.
- Operating instructions provided below only address the RAFNA railgear equipment. Applicable railway company procedures and policies must be adhered to.
- Railway company rules governing rail travel must be observed at all times.
- Before performing any work under the vehicle or railgear, ensure the engine is turned off and the parking brake is set.
- Never operate the vehicle if the Gross Vehicle Weight Rating (GVWR), Gross Axle Weight Rating Front or Rear (GAWR), or the wheel or tire load ratings are exceeded.

OPERATION AND SERVICE OF FRONT MOUNTING KIT

With the front mounting kit installed on this vehicle, it may be operated as normal, however the front bumper is located further forward than standard. Side wands are located on the front bumper to aid in determining the length and width of the vehicle. Caution must be used when operating the vehicle.

Never operate the vehicle if the Gross Vehicle Weight Rating (GVWR), Gross Axle Weight Rating Front or Rear (GAWR), or the wheel or tire load ratings are exceeded.

The front mounting kit must be serviced regularly to avoid damage to the equipment. Table 1 below provides the Recommended Service Schedule and Table 2 provides Standard Fastener Torque Values.

Table 1: Recommended Service Schedule

Service Required	Initial 62 miles (100 km) of road and/or rail use	Daily	Weekly	Monthly
Inspect front mounting kit fasteners (re-torque if required)		✓	✓	✓

Table 2: Standard Fastener Torque Values

Fastener Size	Fastener Torque Value (ft-lbs) Dry
1" UNC Gr. 8 Fasteners	250
3/4" UNC Gr. 8 Fasteners	175
5/8" UNC Gr. 8 Fasteners	150
1/2" UNC Gr. 8 Fasteners	100
7/16" UNC Gr. 8 Fasteners	65
3/8" UNC Gr. 8 Fasteners	40
1/4" UNC Gr. 8 Fasteners	12