

INSTALLATION OF R-290 REAR MOUNTING KIT 2017-PRESENT FORD F-250/350 4X2/4X4 WITH OEM TOW HITCH

INSTALLATION SAFETY PRECAUTIONS

If any installation problems are encountered, please call G&B Specialties for technical assistance before continuing with the installation process.



- Failure to heed to any of the following warnings could result in severe bodily injury and/or equipment damage.
- Read and understand this manual completely before attempting installation of the equipment.
- Installation instructions provided below only address the RAFNA railgear equipment. Applicable railway company procedures and policies must be adhered to.
- Before performing any work under the vehicle or railgear, ensure the engine is turned off and the parking brake is set.
- Do not start the vehicle with the power steering hoses disconnected. Reconnect all hoses and secure the power steering cooler if the vehicle is started.
- Ensure all removed components are given to the vehicle owner after the installation of the railgear. These components must be re-installed if the railgear is removed from the vehicle.
- Always disconnect the vehicle's battery when welding on the vehicle or railgear to protect the vehicle's electrical system.
- Railway Company rules governing rail travel must be observed at all times.
- Never operate the vehicle if the Gross Vehicle Weight Rating (GVWR), Gross Axle Weight Rating Front or Rear (GAWR), or the wheel or tire load ratings are exceeded.

INSTALLATION OF REAR MOUNTING KIT

The following procedure details the installation of the rear mounting kit. The hardware required for this installation is listed in Table 1.

Part Number	Description	# Req.	Remarks	Check
R-33275D	Rear Mounting Bracket, Drivers Side	1		
R-33275P	Rear Mounting Bracket, Pass Side	1		
R-2960	Railgear Mounting Shim, ½"	4		
R-2960A	Railgear Mounting Shim, 1"	4		
R-2631	Railgear Mounting Shim, 2"	4		
R-33260	Spacer Bumper	4		
R-33261	Machined Bolt	2		
R-990KIT-299C	7/8" UNC Gr. 8 Nylon Insert Lock Nut	2	Rear Mounting Bracket Install	
	7/8" Gr. 8 Washer	4		
	1/2" UNC Gr. 8 Bolt x 2.250" Long	8		
	1/2" UNC Gr. 8 Nylon Insert Lock Nut	8		
	1/2" Gr. 8 Washer	16		
	3/4" UNC Gr. 8 Bolt x 5.50" Long	4	Railgear Mounting	
	3/4" UNC Gr. 8 Bolt x 6.50" Long	4		
	3/4" UNC Gr. 8 Bolt x 7.50" Long	4		
	3/4" UNC Gr. 8 Bolt x 8.50" Long	4		
	3/4" Gr. 8 Washer	8		
	3/4" UNC Gr. 8 Nylon Insert Lock Nut	4		

1. Remove the original spare tire and spare tire heat shield from under the vehicle's cargo box if so equipped. The original spare tire will not be re-installed.
2. Remove the tow hitch from the rear of the frame if so equipped.
3. Place each rear mounting bracket against the underside and outside of the frame rails as shown, just ahead of the rear spring hangers. The three slots in the side of each rear mounting plate should align with the three slots in the side of the frame. The four slots in the bottom of each rear mounting plate should align with the four slots in the lower flange of the frame for the OEM tow hitch.
4. Fasten each rear mounting bracket to the bottom of the frame as shown.

For Install with OEM Tow Hitch (Figure 1, 2 & 3)

1. Install the OEM tow hitch to the bottom of the rear mounting bracket.
2. Tighten but do not torque the fasteners.
3. Ensure the mounting brackets are tight to the underside and outside of the frame and are aligned with each other and that the support bracket is sitting flush against the rear mounting bracket.
4. Torque the 14 mm OEM fasteners to 150 ft-lb dry and the 19 mm OEM fasteners to 175 ft-lb dry. Do not over torque.
5. Remove both bumper mounting brackets and modify slots as per Figure 3.
6. Remount the modified bumper brackets and mount bumper spacer, P/N R-33260 to tow hitch.
7. The supplied railgear mounting shims are to be used as required when mounting the railgear to the rear mounting plates. See Table 2 for bolt length to be used with shim.

Note:

A minimum of 3" of shim is required when installing this unit in conjunction with the OEM tow hitch. If less than 3" of shim is used the railgear may come in contact with the tow hitch when stowed in the road position. If the recommended unit installation height, as specified in the railgear installation manual, cannot be achieved with a minimum of 3" of shim, the tow hitch must be removed from the vehicle or modified by the installer at their own discretion.

Shim Dimension	Bolt Length
3"	5 ½"
3 ½"	5 ½"
4"	6 ½"
4 ½"	6 ½"
5"	7 ½"
5 ½"	7 ½"
6"	8 ½"

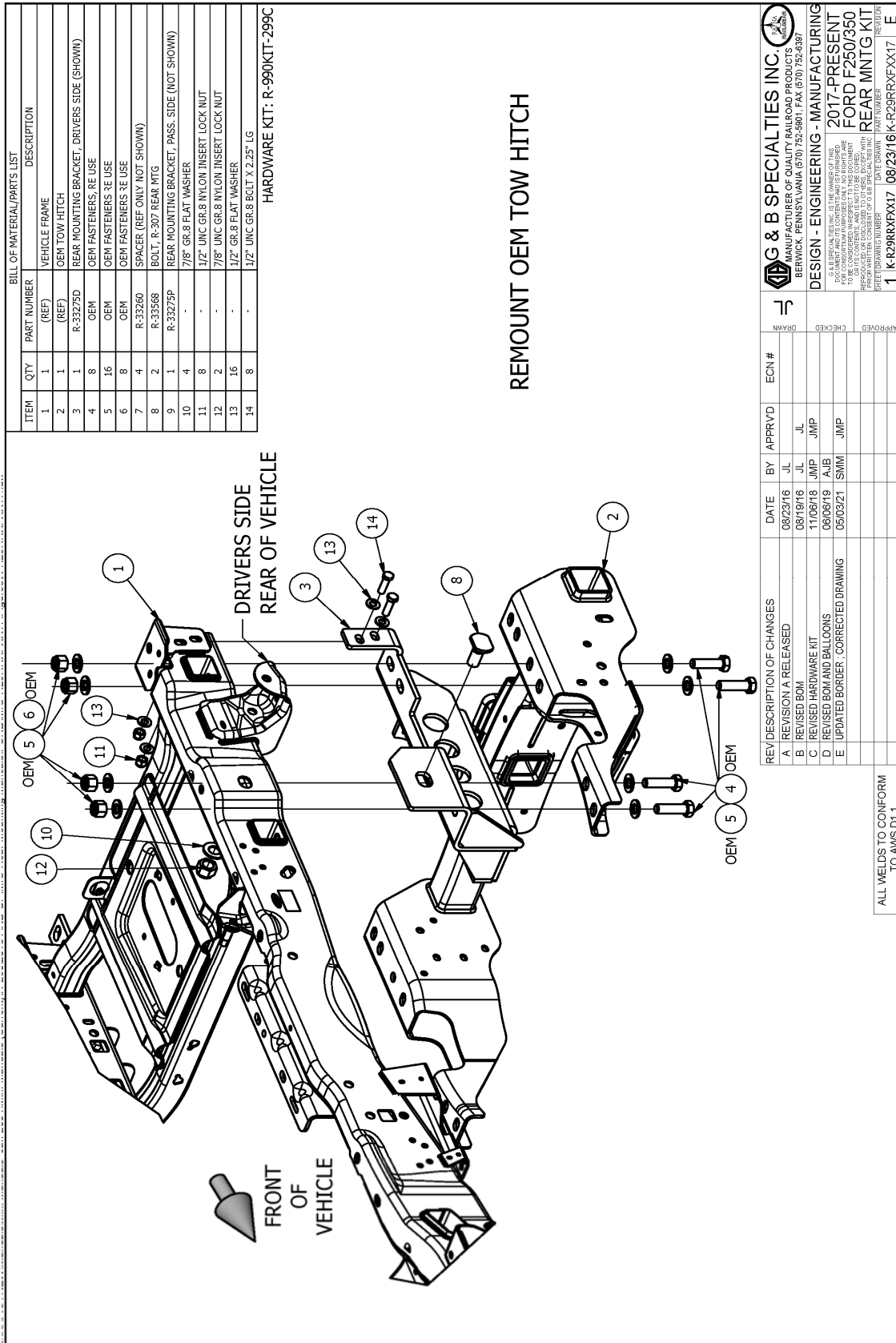

Figure 1

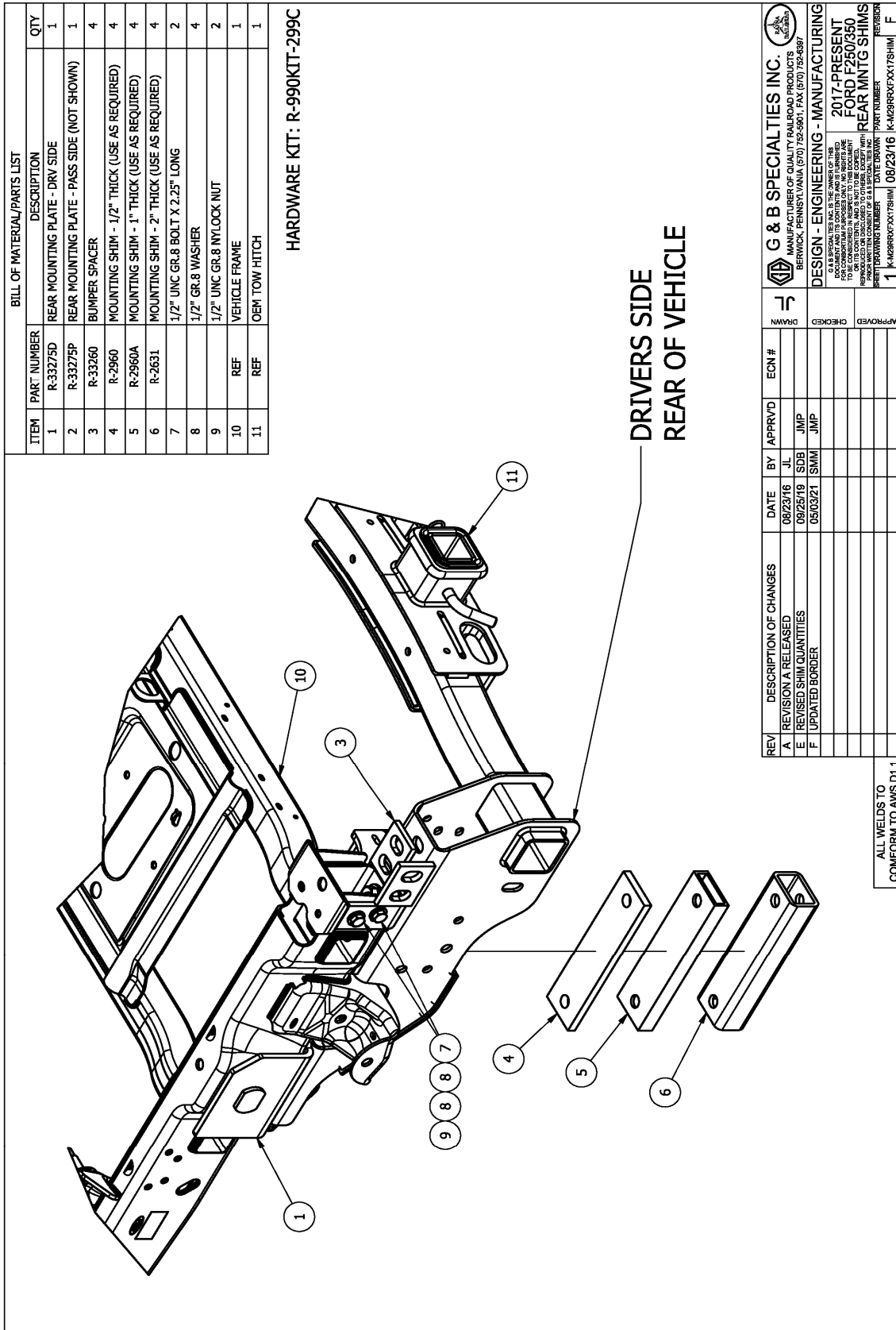

Figure 2



Figure 3

BUMPER BRACKET MODIFICATION

Remove both driver's side bumper brackets, and passenger side bumper bracket. Extend slots as per above photo on both driver and passenger bumper brackets. Reinstall bumper brackets to vehicle.



Figure 4

OPERATION, SERVICE & PARTS OF R-290 REAR MOUNTING KIT 2017-PRESENT FORD F-250/350 4X2/4X4 WITH OEM TOW HITCH

OPERATION SAFETY PRECAUTIONS

If any operating, services or parts problems are encountered, please call G&B Specialties for technical assistance.

- Failure to heed to any of the following warnings could result in severe bodily injury and/or equipment damage.
- Read and understand this manual completely before attempting operation of the railgear equipped vehicle.
- Operating instructions provided below only address the RAFNA railgear equipment. Applicable railway company procedures and policies must be adhered to.
- Railway company rules governing rail travel must be observed at all times.
- Before performing any work under the vehicle or railgear, ensure the engine is turned off and the parking brake is set.
- Never operate the vehicle if the Gross Vehicle Weight Rating (GVWR), Gross Axle Weight Rating Front or Rear (GAWR), or the wheel or tire load ratings are exceeded.

OPERATION AND SERVICE OF REAR MOUNTING KIT

With the rear mounting kit installed on this vehicle, it may be operated as normal.

Never operate the vehicle if the Gross Vehicle Weight Rating (GVWR), Gross Axle Weight Rating Front or Rear (GAWR), or the wheel or tire load ratings are exceeded.

The rear mounting kit must be serviced regularly to avoid damage to the equipment. Table 1 below provides the Recommended Service Schedule and Table 2 provides Standard Fastener Torque Values.

Table 1: Recommended Service Schedule				
Service Required	Initial 100 km (62 Miles) of road and/or rail use	Daily	Weekly	Monthly
Inspect rear mounting kit fasteners (re-torque if required)		✓	✓	✓

Table 2: Standard Fastener Torque Values	
Fastener Size	Fastener Torque Value (ft-lbs) Dry
1" UNC Gr. 8 Fasteners	250
¾" UNC Gr. 8 Fasteners	175
⅝" UNC Gr. 8 Fasteners	150
½" UNC Gr. 8 Fasteners	100
⅜" UNC Gr. 8 Fasteners	40
¼" UNC Gr. 8 Fasteners	12