

INSTALLATION OF R-450 MANUAL FRONT AXLE LOCK KIT (ROD) 2017 AND UP FORD F-450/F-550 4X4, 4X2

INSTALLATION SAFETY PRECAUTIONS

If any installation problems are encountered, please call G&B Specialties for technical assistance before continuing with the installation process.



- Failure to heed to any of the following warnings could result in severe bodily injury and/or equipment damage.
- Read and understand this manual completely before attempting installation of the equipment.
- Installation instructions provided below only address the Rafna railgear equipment. Applicable railway company procedures and policies must be adhered to.
- Before performing any work under the vehicle or railgear, ensure the engine is turned off and the parking brake is set.
- Beware of all pinch points on the railgear and keep all parts of the body clear.
- Ensure all removed components are given to the vehicle owner after the installation of the railgear. These components must be re-installed if the railgear is removed from the vehicle.
- Always disconnect the vehicle's battery when welding on the vehicle or railgear in order to protect the vehicle's electrical system.

INSTALLATION OF MANUAL FRONT AXLE LOCK KIT (ROD)

The following procedure details the installation of the Rod Operated Front Axle Lock Kit. The hardware required for this installation is listed in the table below.

Table 1: K-R45AVXFX005 (R-450 Rod Operated Front Axle Lock Kit)

Part Number	Description	Req.
R-12029D	L-Bracket Weldment Drivers Side	1
R-12029P	L-Bracket Weldment Passengers Side	1
R-5635	Insulator Washer	4
R-4912-A	Hook	2
R-12018	Spacer	2
R-12031	Support Bracket	2
R-4911	Bracket	2
R-4914	Hook Catch	2
R-6944	Rod Guide	2
R-6947	Lock Tab	4
R-6948A	Pull Rod	2
R-1650	Plate	2
R-4686	Quick Release Pin	2
R-12032	Washer, Fuel Cooler Spacer	1
R-990KIT-116A	Nylock Nut, UNC, 1/4"	2
	Flat Washer, Type A, 1/4"	2
	Hex Screw, UNC, 3/8" x 4" Lg	2
	Nylock Nut, UNC, 3/8"	4
	Flat Washer, Type A, 3/8"	6
	Nylock nut, UNC, 1/2"	2
	Flat Washer, Type A, 1/2"	8
	Hex Screw, UNC, 3/4" x 5" Lg	2
	Hex Screw, UNC, 3/4" x 5 1/2" Lg	2
	Nylock nut, UNC, 3/4"	6
	Flat Washer, Type A, 3/4"	10
Cotter pin, 3/16" x 2" Lg	2	

The manual front axle lock kit is to be positioned just rearward of the vehicle's front suspension springs. Mounting holes in the hook hanger and bracket will align with some existing holes in the vehicle frame and suspension arm, respectively. The axle lock hook is designed to swing toward the front of the vehicle while disengaged for the road position and toward the rear of the vehicle while engaged for the rail position. The pull rod is fastened to the hook and routed toward the front of the vehicle to control the hook position.

1. Remove fuel cooler (Figure 8) from inside frame. Hoses should not have to be removed, just bolts taken out to be free of the frame. We will be using one of the existing mounting points for our bracket. Clip will need to be removed from square hole. See (Fig.5) for location.

2. Pop out wiring clips, grounding stud, etc. on top of the frame so that the bracket will sit flat on the frame. Brake clip and grounding stud are located on bracket for re-installation. Pop rivet can be removed from brake clip and installed on bracket with supplied hardware. See Fig. 7 for clip and pop rivet.
3. Find the slotted hole on top of the frame. Take bracket R-12029D (Driver's Side) and align the locating slug on the bracket with the slot in the frame. When done correctly, slug should drop into the slot on the frame and the bracket sit against the top and outer surfaces of the frame. See (Fig. 1).
4. With the bracket on the frame, center punch the slot on the bracket. Remove bracket and drill a 49/64" hole. Hole should line up with existing square hole where we removed the clip from earlier. Check with supplied 3/4" bolt to ensure bolt sits parallel and is not angled. Hole may need to be reamed to ensure this. The hole on the outside of the frame can also be obtained by drilling the square hole on the inside of the frame through to the outside. The bracket is slotted for this reason. Just ensure bolt sits straight and not on an angle. Once hole is in place and bolt sits parallel, re-install fuel cooler leaving out the clip we removed. Install bracket to frame, using R-12032 and 3/4" hardware as show in Fig. 1 & 2. See Fig. 8 for proper install reference. (Passenger side will need the hole drilled through to the inside of the frame. There are no holes present on the passenger side.)
5. On the radius arm you will see a slotted hole with a hole next to it. Take R-4911 and place it on the radius arm with the larger hole in the bracket aligned with the slot, positioned closest to the hole side of the slot. See (Fig.6) Place 3/4" bolt that was supplied through the bracket and radius arm to help hold the bracket, and with the bracket against the bottom of the radius arm, mark the center of the small hole of the bracket on frame. You may also mark the center of the hole on the inside of the frame. Drill a 13/32" hole through the radius arm, or on the inside and outside where marked. With hole drilled, install bracket using the 3/4" and 3/8" hardware supplied in kit. See (Fig.1 & 3) for reference. Ensure not to over-tighten bolts and deform the radius arm.
6. Assemble the hook, R-4912-A, and bracket, R-12031, onto the all thread and stud as shown in Fig. 2. If lateral adjustment is required supplied spacer can be trimmed down, or washers can be added into assembly to maintain proper clearance with frame, suspension arm, and hook. Nylock nut should be tightened enough to secure hook, but not hinder it from swinging.
7. Position each hook so that it is hanging vertically with the hooking surface horizontal. Position each hook catch on each bracket so that the vertical side of the hook just touches the forward-most part of the hook catch and there is a minimal gap between the bottom of the hook catch and the hooking surface. Weld each hook catch to each bracket using a 3/8" all around fillet weld
8. Position each plate at about the center of the forward-facing vertical edge of each hook as shown. Tack weld each plate to each hook temporarily. (Fig.4)

9. Assemble the short-bent end of each pull rod with each plate as shown using one 1/2" washer and one 3/16" x 2" cotter pin. Route the pull rod around the front suspension coil springs and other vehicle components so that it extends out toward the front of the vehicle alongside the railgear front mounting brackets. The pull rods can be heated and bent to fit. Trim the vehicle front bumper as required. (Fig.4)
10. Slide each rod guide onto each pull rod from the handle end at the front of the vehicle. Position each rod guide so that it is approximately 2-3" from the handle end of the pull rod when the pull rod is pushed all the way in, so the hook engages the hook catch. Tack weld each rod guide to a convenient location on the railgear or vehicle temporarily. Do not weld the rod guide to the railgear guide tubes or hydraulic cylinders. It may be necessary to fabricate a bracket to position the rod guides as desired.
11. Test the stroke of each pull rod to ensure that each hook can be fully engaged and disengaged from the hook catch. Ensure that all parts of the axle lock system are clear of all vehicle components. If necessary, the plates previously tack welded to the vertical edge of the hooks can be relocated to adjust the stroke of the pull rods. The rod guides can also be relocated. Once each plate and rod guide position are verified, fully weld each plate to each hook and fully weld each rod guide to the railgear, vehicle, or fabricated bracket.
12. With each pull rod pushed all the way in so the hook fully engages the hook catch, position one lock tab on the pull rod as shown so the hole in the lock tab aligns with the front most holes in the rod guide. Weld the lock tab to the pull rod.
13. With each pull rod pulled out so that the hook fully disengages the hook catch with at least 1/2" clearance, position one lock tab on the pull rod as shown so the hole in the lock tab aligns with the rear most holes in the rod guide. Weld the lock tab to the pull rod.
14. Attach each pin to each chain on the rod guides. Pull the pull rods to fully disengage the hooks and insert the pins through the rod guides and lock tabs.
15. Paint all areas that were welded or heated.
16. Ensure that there is sufficient clearance between the front axle lock components and all vehicle components through their full range of motion.
17. Test the operation of the front axle lock.

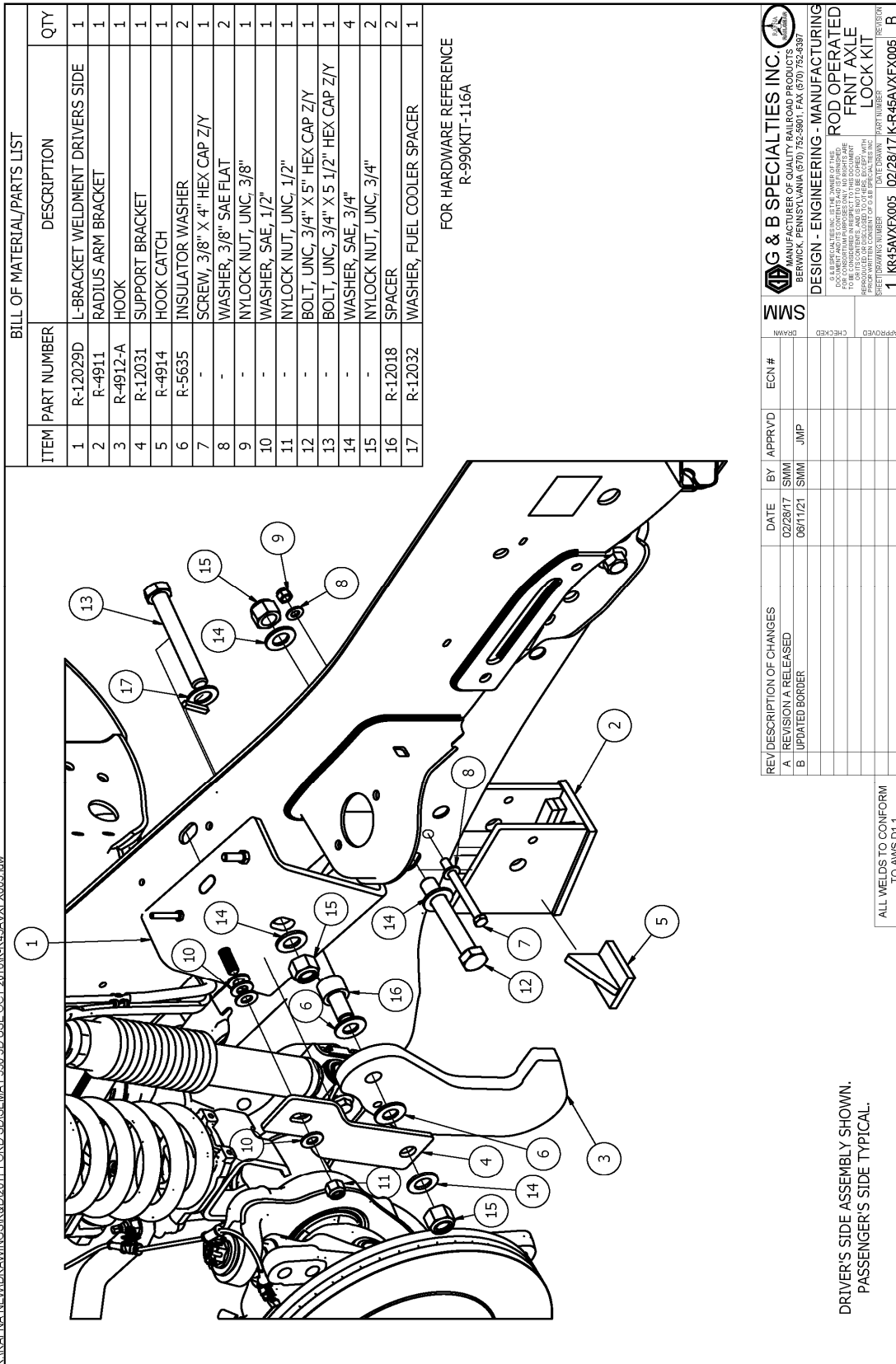

Figure 1

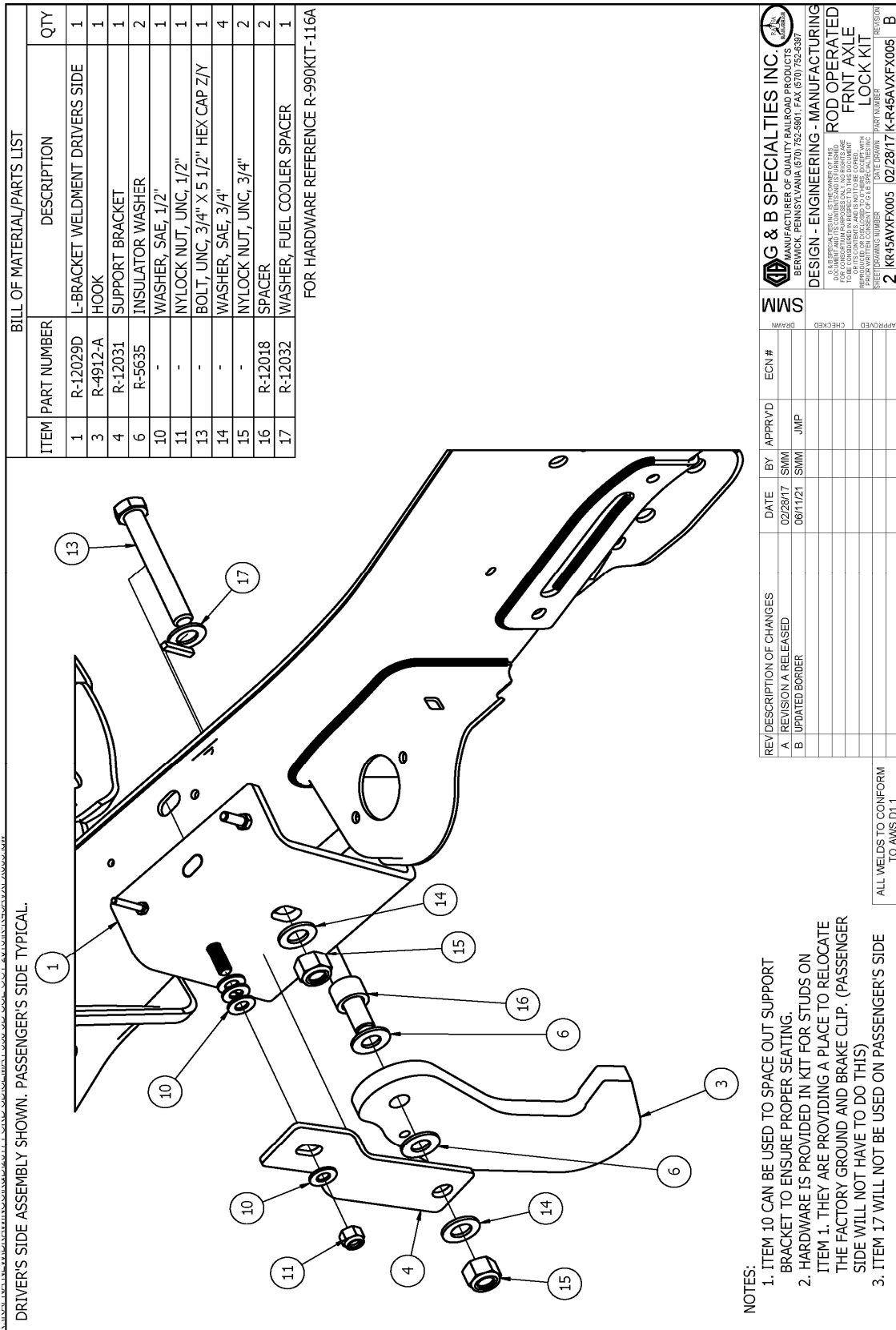

Figure 2

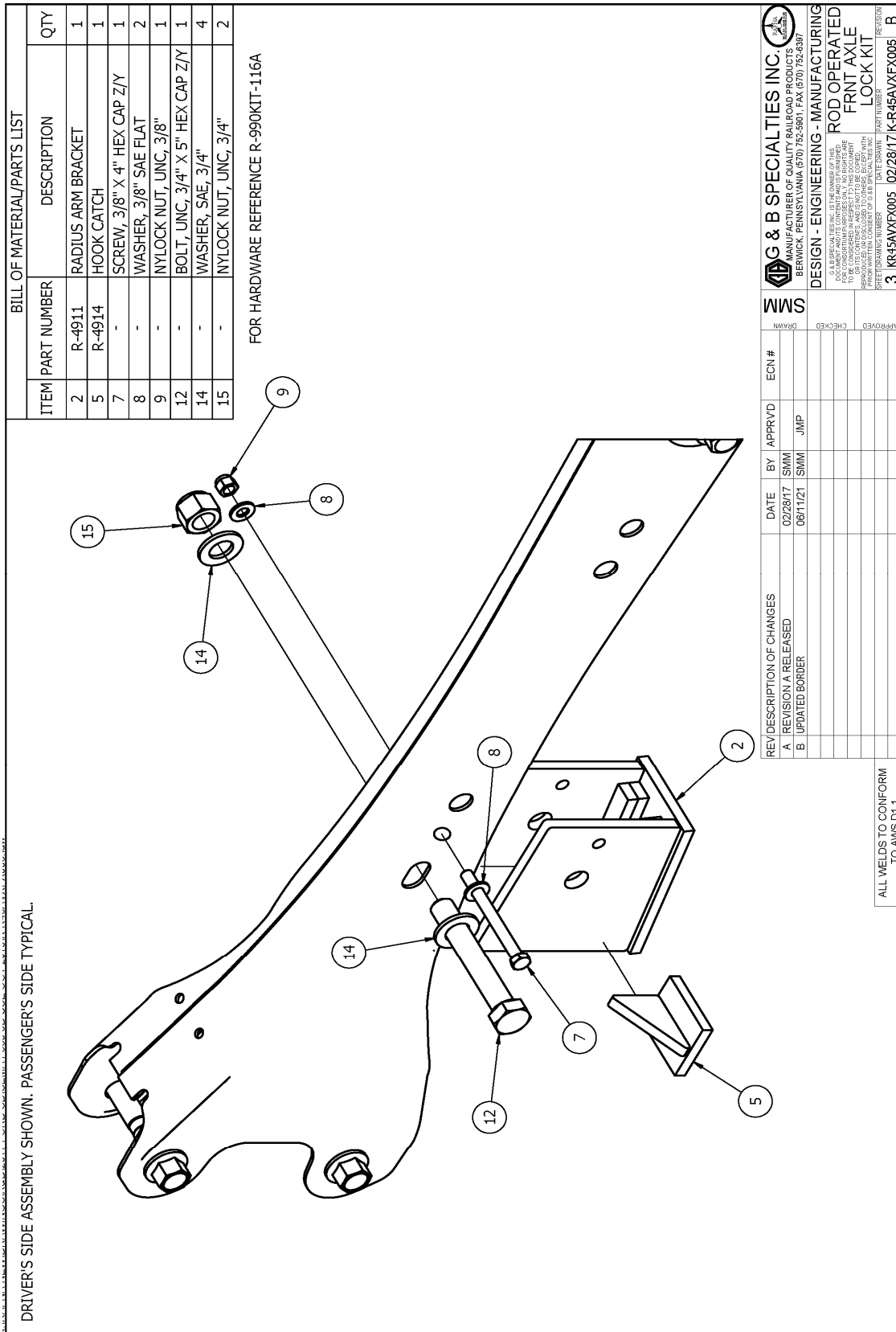

Figure 3

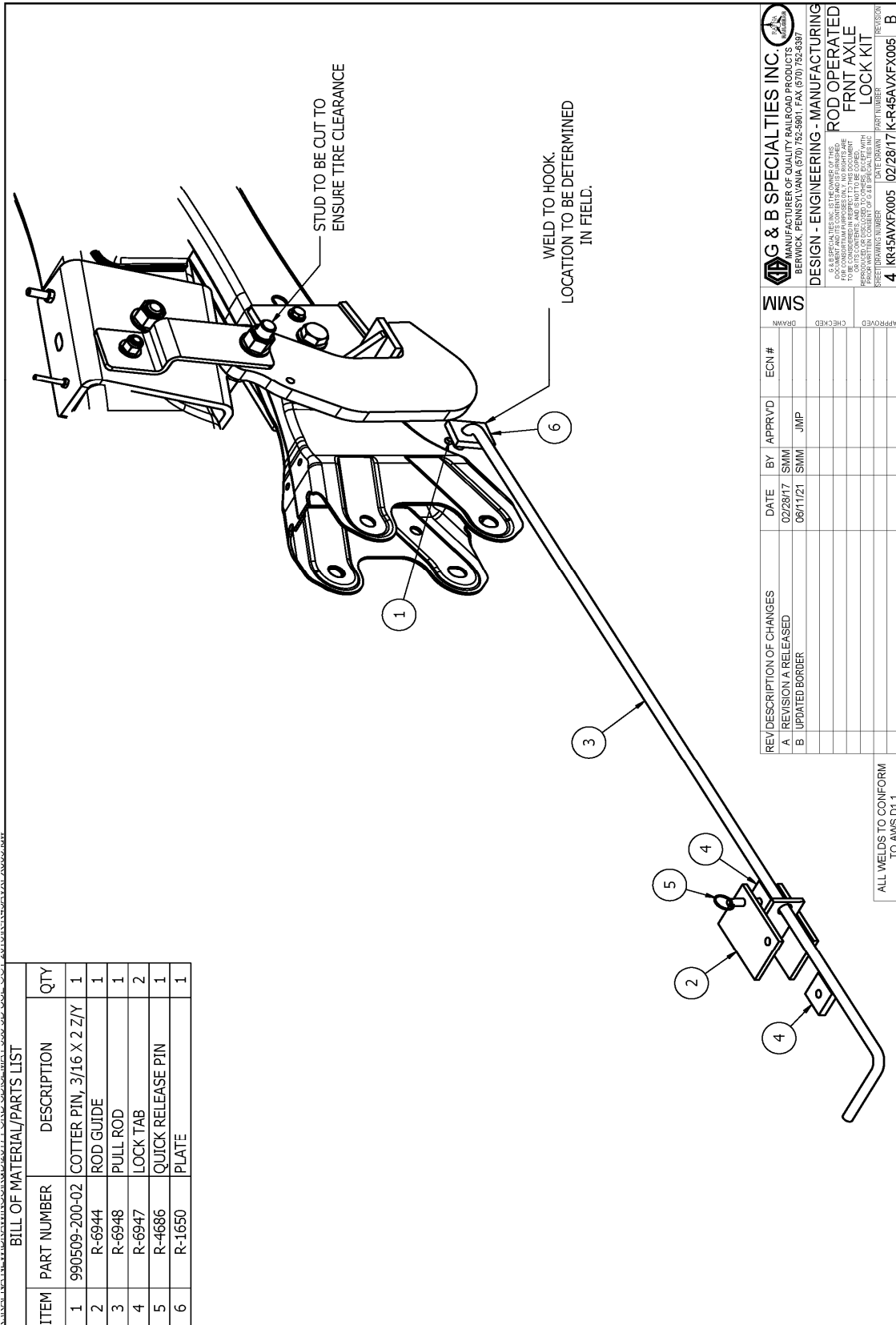

Figure 4

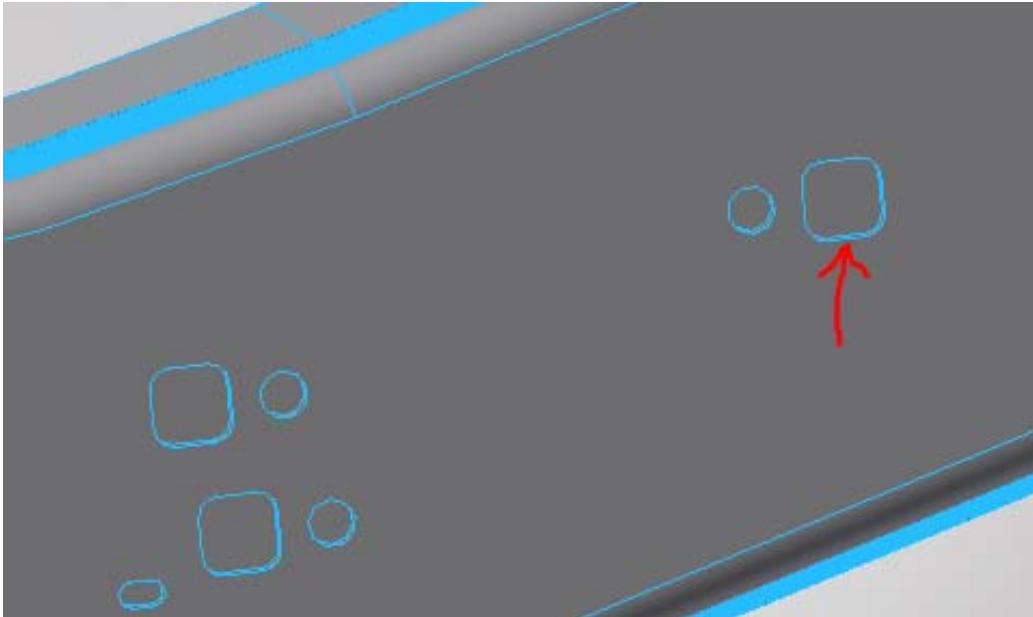

Figure 5

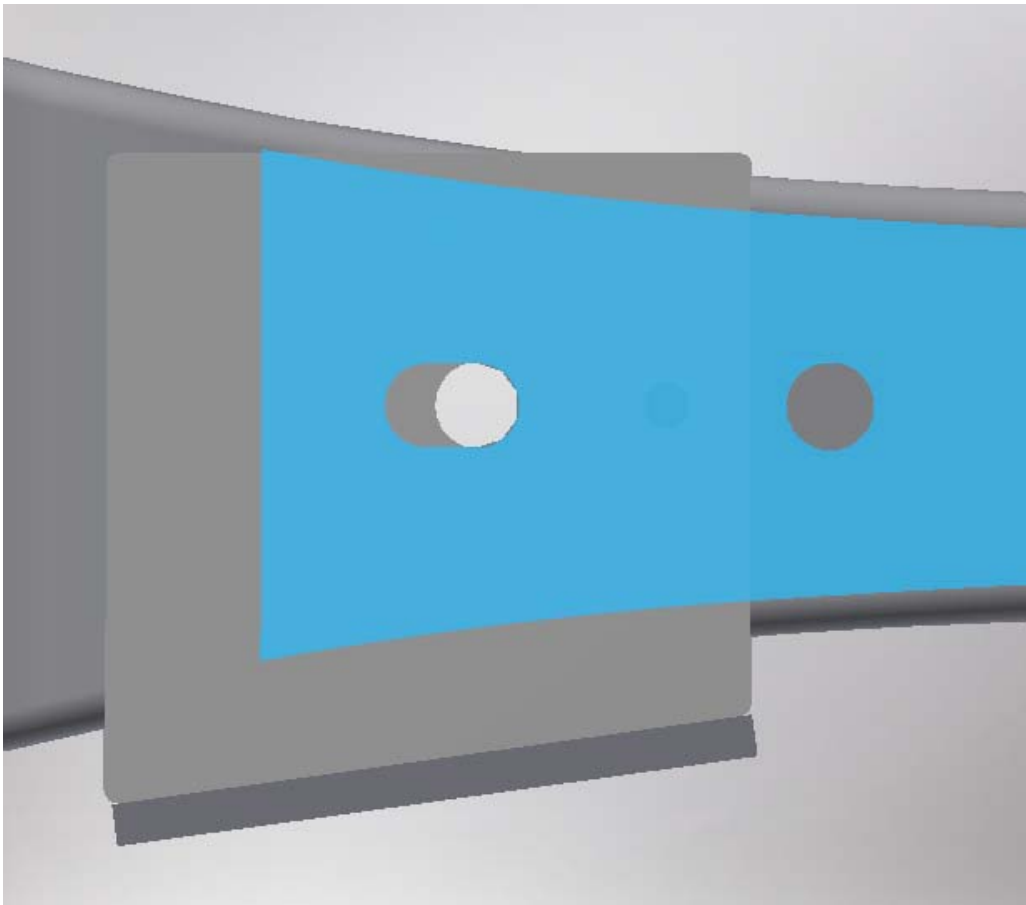

Figure 6



Figure 7

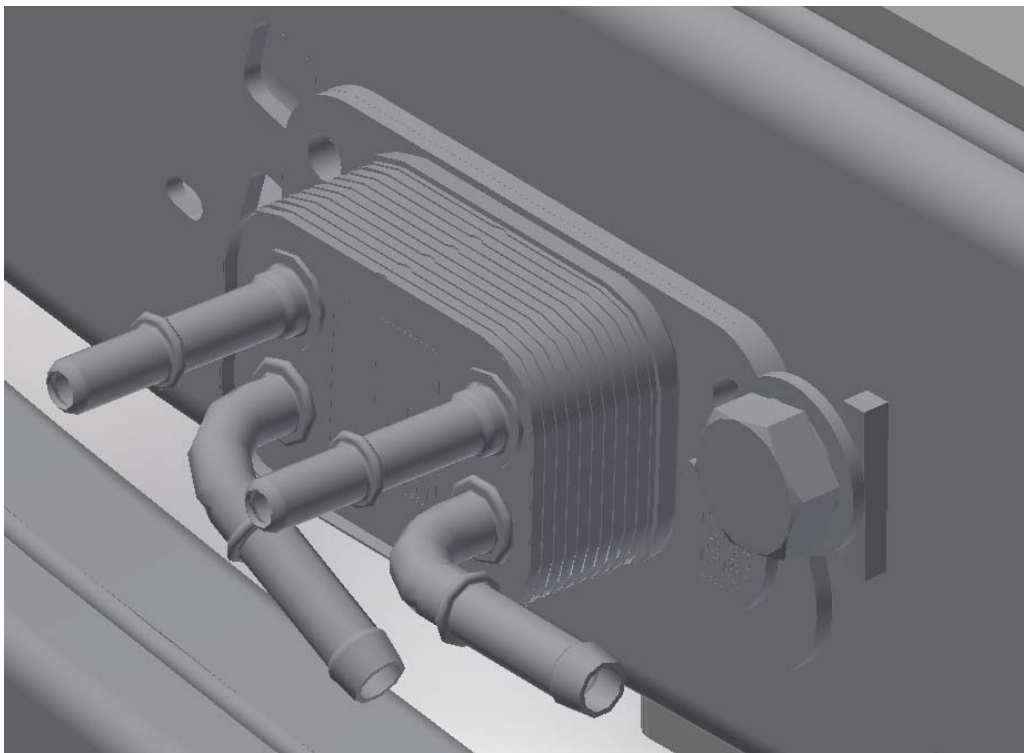

Figure 8

OPERATION OF R-450 MANUAL FRONT AXLE LOCK KIT (ROD) 2017 AND UP FORD F-450/F-550 4X4, 4X2

OPERATION SAFETY PRECAUTIONS

If any installation problems are encountered, please call G&B Specialties for technical assistance before continuing with the installation process.



- Failure to heed to any of the following warnings could result in severe bodily injury and/or equipment damage.
- Read and understand this manual completely before attempting operation of the railgear equipped vehicle.
- Operating instructions provided below only address the Rafna railgear equipment. Applicable railway company procedures and policies must be adhered to.
- Railway Company rules governing rail travel must be observed at all times.
- Before performing any work under the vehicle or railgear, ensure the engine is turned off and the parking brake is set.
- Ensure all removed components are given to the vehicle owner after the installation of the railgear. These components must be re-installed if the railgear is removed from the vehicle.
- Always disconnect the vehicle's battery when welding on the vehicle or railgear in order to protect the vehicle's electrical system.

MANUAL FRONT AXLE LOCK OPERATION (ROD)

With the Front Axle Lock kit installed on this vehicle, it may be operated as normal.

Never operate the vehicle if the Gross Vehicle Weight Rating (GVWR), Gross Axle Weight Rating Front or Rear (GAWR), or the wheel or tire load ratings are exceeded.

Refer to the Railgear Kit Operation, Service and Parts manual for information on the mechanical operation, service and parts of the railgear.

PLACING VEHICLE ON RAIL

1. Grasp the handle for the axle lock rod (one for each side), pull the pin and push the rod in toward the front bumper. Insert pin to lock in place.
2. Visually inspect that both axle lock-up hooks have fully engaged the hook catches welded to the front suspension arms.
3. Proceed to lower the front railgear unit.
4. As the front rail wheels engage the rail, the front of the vehicle will begin to rise.
5. Continue to lower the front railgear unit until the cylinders are fully extended and the railgear lock up hook has engaged.
6. With the front railgear unit in the fully locked rail position, the front tires should be approximately 2" to 3" above the rail head.

REMOVING VEHICLE FROM RAIL

1. Disengage the railgear lock and raise the railgear to the full locked road position.
2. Grasp the handle for the axle lock rod (one for each side), pull the pin and pull the rod out away the front bumper. Insert pin to lock in place.
3. Visually inspect that both axle lock-up hooks have fully retracted from the hook catches welded to the front suspension arms.

MANUAL FRONT AXLE LOCK ADJUSTMENT

The manual front axle lock is adjusted when the vehicle is resting on its tires in its minimum loaded condition with the railgear in the road position and the axle lock engaged. For the axle lock to function properly there are three adjustments to be made:

1. There should be a clearance of 1/8" to 3/8" between the hooking surface of each hook and hook catch. If the clearance is larger than 3/8", steel shims can be welded to the bottom of the hook catch. If the clearance is less than 1/8", any previously installed shims can be removed. If there are no shims to remove, the hook catch can be cut off the bracket and re-welded higher up on the bracket using a 3/8" all around fillet weld.
2. The rear vertical edge of each hook should rest flat against the forward edge of the hook catch when the axle lock is fully engaged. This can be adjusted by cutting the hook catch off the bracket and re-welding it in place using a 3/8" all around fillet weld.
3. Each hook must clear the suspension arm by at least 1/2" through its full range of motion. The hooks can be moved inboard and outboard on the hook hanger pivot post by adjusting the number of plastic washers on each side of the hook.
4. Paint all welded areas after the axle lock is properly adjusted.
5. Ensure that there is sufficient clearance between the front axle lock components and all vehicle components through their full range of motion.

SERVICE OF AXLE LOCK KIT

The Axle Lock kit must be serviced regularly to avoid damage to the equipment. Table 1 below provides the Recommended Service Schedule and Table 2 provides Standard Fastener Torque Values.

Table 1: Recommended Service Schedule

Service Required	Daily	Weekly	Monthly	3 Months	6 Months
Inspect front axle lock fasteners (re-torque if required)	✓	✓	✓	✓	✓
Check / adjust front axle lock hook clearance (see procedure)					✓

Table 2: Standard Fastener Torque Values

Fastener Size	Fastener Torque Value (ft-lbs) Dry
1" UNC Gr. 8 Fasteners	250
¾" UNC Gr. 8 Fasteners	175
⅝" UNC Gr. 8 Fasteners	150
½" UNC Gr. 8 Fasteners	100
⅜" UNC Gr. 8 Fasteners	40
¼" UNC Gr. 8 Fasteners	12