

## INSTALLATION OF R-450 ROTATING REAR RAILGEAR KIT W/ LEVER LOCK- UP 2019-PRESENT RAM 4500/5500 CHASSIS CAB

### INSTALLATION SAFETY PRECAUTIONS

If any installation problems are encountered, please call G&B Specialties, Inc. for technical assistance before continuing with the installation process.



- Failure to heed to any of the following warnings could result in severe bodily injury and/or equipment damage.
- Read and understand this manual completely before attempting installation and operation of the equipment.
- Installation and operation instructions provided below only address the G&B Specialties railgear equipment. Applicable railway company procedures and policies must be adhered to.
- Before performing any work under the vehicle or railgear, ensure that the engine is turned off and the parking brake is set.
- Beware of all pinch points on the railgear and keep all parts of the body clear.
- Always disconnect the vehicle's battery when welding on the vehicle or railgear in order to protect the vehicle's electrical system.
- Railway company rules governing rail travel must be observed at all times.
- Ensure that the position and function of all railgear controls are known before attempting operation.
- Ensure the railgear is locked in road position before starting road travel.
- Ensure all body parts and loose clothing are clear of any moving parts of the equipment.
- If misalignment of the railgear equipment is indicated, promptly perform the alignment procedure.
- Before performing any work under the vehicle or railgear, ensure the engine is turned off and the parking brake is set.
- Never operate the vehicle if the Gross Vehicle Weight Rating (GVWR), Gross Axle Weight Rating Front or Rear (GAWR), or the wheel or tire load ratings are exceeded.

**REAR RAILGEAR KIT**

The following procedure details the installation of the rotating rear railgear kit. The hardware and parts required for this installation are listed in Table 1.

**Table 1: Rotating Rear Railgear Kit Installation Parts**

Part Number	Description	Qty
R-19061B	Rotating Rear Railgear	1
R-18021	Rear Support Bracket	2
R-001	10" Wheel Assembly	2
R-4646R	Rail Sweep Right Side	1
R-4646L	Rail Sweep Left Side	1
S-001031	Railgear Operation Decal	1
R-18103	Wrench	1
R-4837B	R-450 Axle Lockup, Lever Actuated	1
K-R45XXRX4836	R-450 Rotating Rear Manual Lock-up kit	1
R-990KIT-443 Railgear Mounting	7/16" UNC Gr. 8 Bolt x 1 1/2" Long	6
	7/16" UNC Gr. 8 Bolt x 1 3/4" Long	4
	1/2" UNC Gr. 8 Bolt x 1 3/4" Long	4
	1/2" UNC Gr. 8 Bolt x 2" Long	8
	5/8" UNC Gr. 8 Bolt x 2 1/4" Long	4
	3/4" UNC Gr. 8 Bolt x 2 1/4" Long	4
	7/16" Gr. 8 Washer	20
	1/2" Gr. 8 Washer	24
	5/8" Gr. 8 Washer	8
	3/4" Gr. 8 Washer	8
	7/16" UNC Gr. 8 Nylon Insert Lock Nut	10
	1/2" UNC Gr. 8 Nylon Insert Lock Nut	12
	5/8" UNC Gr. 8 Nylon Insert Lock Nut	4
3/4" UNC Gr. 8 Nylon Insert Lock Nut	4	

## INSTALLATION OF REAR RAILGEAR KIT

1. To install the railgear at the correct height, ensure that the vehicle is resting on its six properly inflated tires. Remove tail lights.
2. Position and support the railgear so that the railgear mounting boxes are on either side of the rear of the vehicle frame with the blind end of the hydraulic cylinders facing the rear of the vehicle. The mounting boxes should be flush with the rear and top surface of the vehicle frame (as a starting point) and fit around the vehicle's suspension hangers. The holes in the mounting boxes should align with existing holes in the rear of the vehicle frame. It may be necessary to loosen or remove the fasteners that support the railgear axle lock system to be able to fit the railgear on the frame. Once the railgear is on the frame, tighten and torque the 1/2" fasteners securing the railgear lock system to the railgear to 100 ft-lbs dry. Do not over torque.
3. Ensure that there is approximately 21.5" between the railgear-to-mounting box interface and the ground as shown in Figure 1. The slots in the mounting boxes will allow for approx. 1/4" of vertical adjustment, either up or down. If the 21.5" mounting height cannot be achieved, the vehicle suspension will need to be modified. This modification is not included with the RAFNA railgear.
4. Fasten each railgear mounting box to the vehicle frame using two 5/8" x 2" long bolts, four 5/8" washers and two 5/8" nuts through the existing frame holes at the rear as shown.
5. Repeat step four for two 7/16" x 1 3/4" long bolts, washer and nuts through the existing frame holes as shown.
6. Using the front-most bottom hole in each railgear mounting box as a guide, drill a 25/32" hole through the vehicle frame.
7. Fasten each railgear mounting box to the vehicle frame using through the drilled hole using 3/4" supplied hardware as shown.
8. Using the center hole in each railgear mounting box as a guide, repeat steps 6 and 7.
9. Fasten each rear support bracket to each railgear mounting box using two 1/2" x 1.75" long bolts, four 1/2" washers and two 1/2" nuts. Slide support bracket up until the top of the bracket is resting on the bottom of the truck frame. Torque the 1/2" fasteners to 100 ft-lbs dry. Do not over torque.
10. Torque the 5/8" fasteners to 150 ft-lbs dry and the 3/4" fasteners to 175 ft-lbs dry. Do not over torque.
11. Place the rail wheels below the mounting tables on the railgear axle. Place the rail sweeps to the rear of the rail wheels and on top of the mounting tables. Fasten the rail wheels and rail sweeps to the mounting tables with eight 1/2" x 2.25" long bolts, sixteen 1/2" washers and eight 1/2" nuts.

12. Tighten but do not torque the 1/2" fasteners as they will be torqued following the railgear alignment procedure.

Proceed to install the railgear hydraulic system as per the Hydraulic Kit Installation manual before continuing with the following steps.

13. Follow the Rail Wheel Load Adjustment procedure detailed in the Operation, Service and Parts section of this manual.

14. Follow the Railgear Alignment procedure detailed in the Operation, Service and Parts section of this manual.

15. Follow the Railgear Lock System Adjustment Procedure detailed in the Operation, Service and Parts section of this manual.

16. Follow the Lockup Kit installation procedure detailed in the Lockup Kit Installation and Operation manual.

17. Follow the Rail Sweep Adjustment procedure detailed in the Operation, Service and Parts section of this manual.

18. Torque all fasteners as detailed in the Operation, Service and Parts section of this manual.

19. Grease the railgear at all lubrication points as detailed in the Operation, Service and Parts section of this manual.

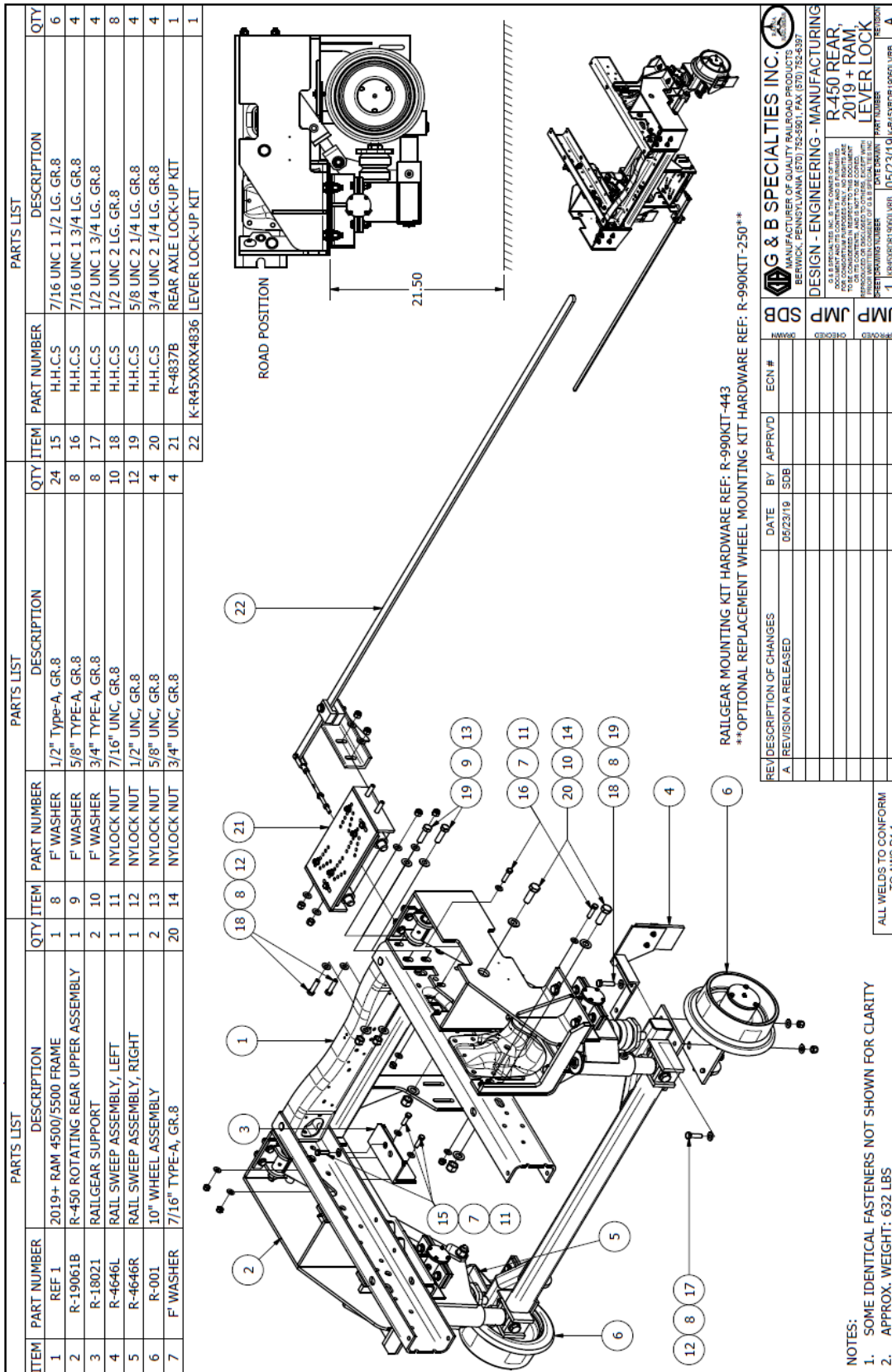

Figure 1

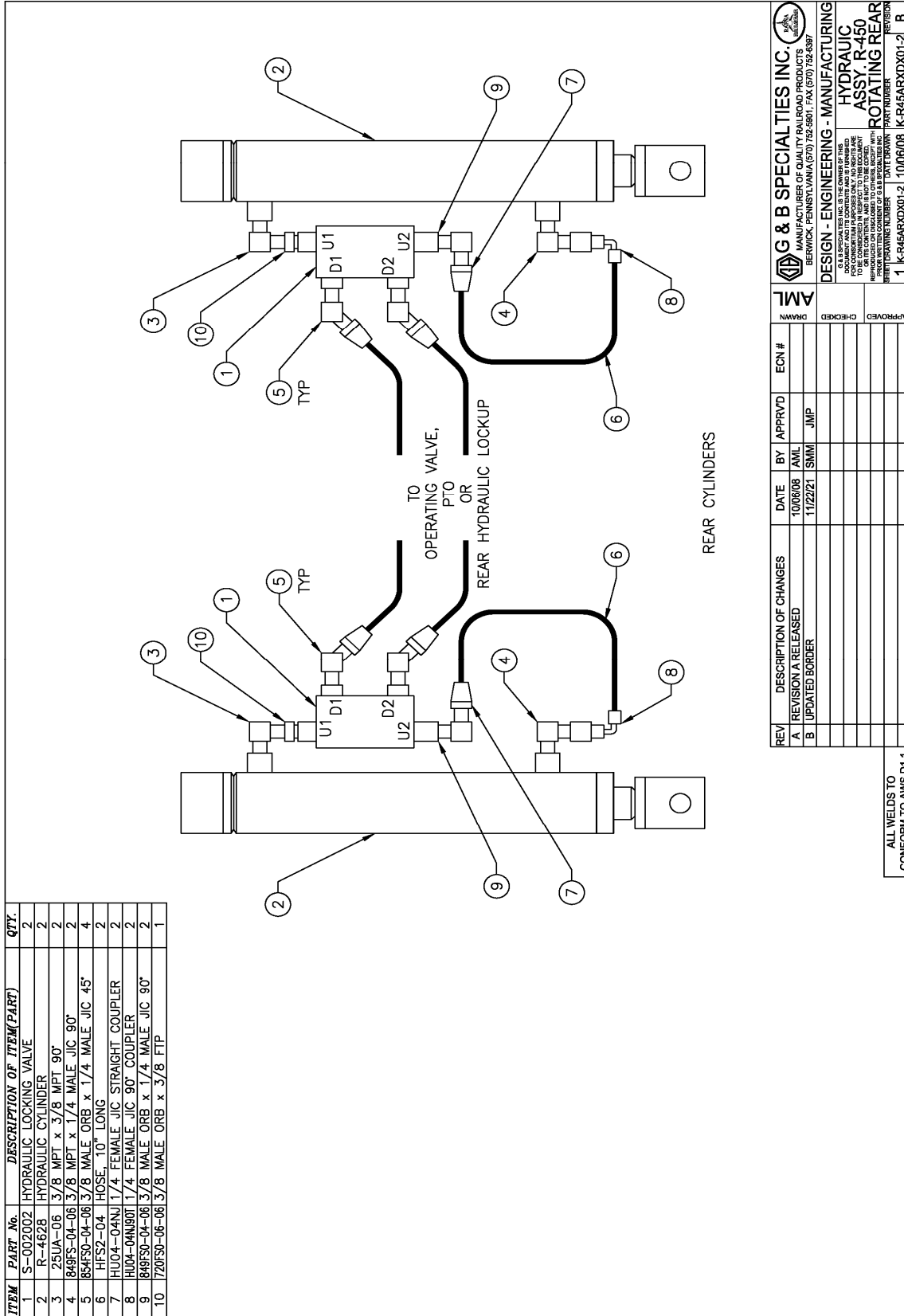

Figure 2

**OPERATION OF R-450 ROTATING REAR RAILGEAR KIT W/ LEVER AXLE  
LOCK-UP  
2008-2018 RAM/SILVER BULLET 4500/5500 CHASSIS CAB**

**OPERATION SAFETY PRECAUTIONS**

If any operating, services or parts problems are encountered, please call G&B Specialties, Inc. for technical assistance.



- Failure to heed to any of the following warnings could result in severe bodily injury and/or equipment damage.
- Read and understand this manual completely before attempting operation of the railgear equipped vehicle.
- Operating instructions provided below only address the RAFNA railgear equipment. Applicable railway company procedures and policies must be adhered to.
- Railway company rules governing rail travel must be observed at all times.
- Ensure that the position and function of all railgear controls are known before attempting operation.
- Ensure the railgear is locked in road or rail position before starting road or rail travel respectively.
- Ensure all body parts and loose clothing are clear of any moving parts of the equipment.
- If misalignment of the railgear equipment is indicated, promptly perform the alignment procedure.
- Before performing any work under the vehicle or railgear, ensure the engine is turned off and the parking brake is set.
- Never operate the vehicle if the Gross Vehicle Weight Rating (GVWR), Gross Axle Weight Rating Front or Rear (GAWR), or the wheel or tire load ratings are exceeded.
- Always disconnect the vehicle's battery when welding on the vehicle or railgear in order to protect the vehicle's electrical system.

## OPERATION OF ROTATING REAR RAILGEAR KIT

With the railgear kit installed on this vehicle, it may be operated as normal, however the vehicle has decreased ground clearance and angles of approach and departure due to the railgear. Caution must be used when operating the vehicle.

Never operate the vehicle if the Gross Vehicle Weight Rating (GVWR), Gross Axle Weight Rating Front or Rear (GAWR), or the wheel or tire load ratings are exceeded.

Refer to the Hydraulic Kit Operation, Service, and Parts section of this manual for information on the location and operation of the railgear hydraulic system controls.

### Placing the Vehicle on Rail - To Lower the Railgear:

1. Disengage the mechanical locking pins by pulling on the lever. Do not force the locking lever. If the lock pins cannot be disengaged, raise the railgear slightly.
2. Hold the locking lever in the disengaged position.
3. Lower the railgear and release the locking lever once the railgear has rotated past the road locked position.
4. As the railgear is being deployed, it will start taking some of the vehicle's load. (If this is not the case, **DO NOT use the railgear**. Inspect the railgear for lubrication and damage.)
5. Continue lowering the railgear until the hydraulic cylinders are fully extended. In this position, the railgear should be 2-3° over center.

### Removing the Vehicle from Rail - To Raise the Railgear:

1. Raise the railgear.
2. Continue raising the railgear until the lock pins click into the road locked position. The hydraulic cylinders should be completely retracted.
3. Ensure that the lock pins are engaged.



**SERVICE OF ROTATING REAR RAILGEAR KIT**

The railgear kit must be serviced regularly to avoid damage to the equipment. Table 2 below provides the Recommended Service Schedule and the detailed service procedures follow.

Figure 3 provides the Non-Standard Fastener Torque Values. Table 3 provides Standard Fastener Torque Values for all other fasteners.

Grease fittings are provided at all railgear lubrication points as shown in Figure 4. The recommended lubricant for all lubrication points on this railgear is **MYSTIK JT-6 LOW TEMP** grease or equivalent. In cold weather areas/seasons, **SHELL DARINA XL102** or equivalent may be used.

**Table 2: Recommended Service Schedule**

Description		Daily	Weekly	Monthly	3Months	6 Months	12 Months
1	Visually inspect the railgear prior to use for damaged or worn parts	✓					
2	Check for loose wheels and fasteners	✓					
3	Ensure the rail gear lock-up system is functioning properly in both the road and rail positions.	✓					
4	Check and adjust truck tire pressure as per requirements	✓					
5	Ensure the vehicle is in good operating condition based on the vehicle operating and maintenance instructions	✓					
6	Check and adjust rail wheel end play (0.005" max.)						✓
7	Inspect railgear wheel flanges for wear. Use the "RAFNA Wheel Flange Indicator" for measurement		✓				
8	Inspect all hydraulic fittings and hoses for leaks or wear	✓					
9	Inspect rail sweeps for proximity to rail head	✓					
10	Grease hydraulic cylinder pivot points			✓			
11	Grease inner tube lower pivot points			✓			
12	Grease inner tubes			✓			
13	Lubricate locking mechanism			✓	✓	✓	
14	Check level on hydraulic reservoir. Top off with appropriate filtered fluid	✓					
15	Inspect and grease railgear wheel bearings						✓
16	Check and correct rail wheel alignment, if gear is removed or damaged, or every 12 months						✓

**Note:**

*For continuous service at ambient temperatures above 40°C (105°F), more frequent lubrication is required.*

Table 3: Standard Fastener Torque Values

Fastener Size	Fastener Torque Value (ft-lbs) Dry
1" UNC Gr. 8 Fasteners	250
3/4" UNC Gr. 8 Fasteners	175
5/8" UNC Gr. 8 Fasteners	150
1/2" UNC Gr. 8 Fasteners	100
3/8" UNC Gr. 8 Fasteners	40
1/4" UNC Gr. 8 Fasteners	12

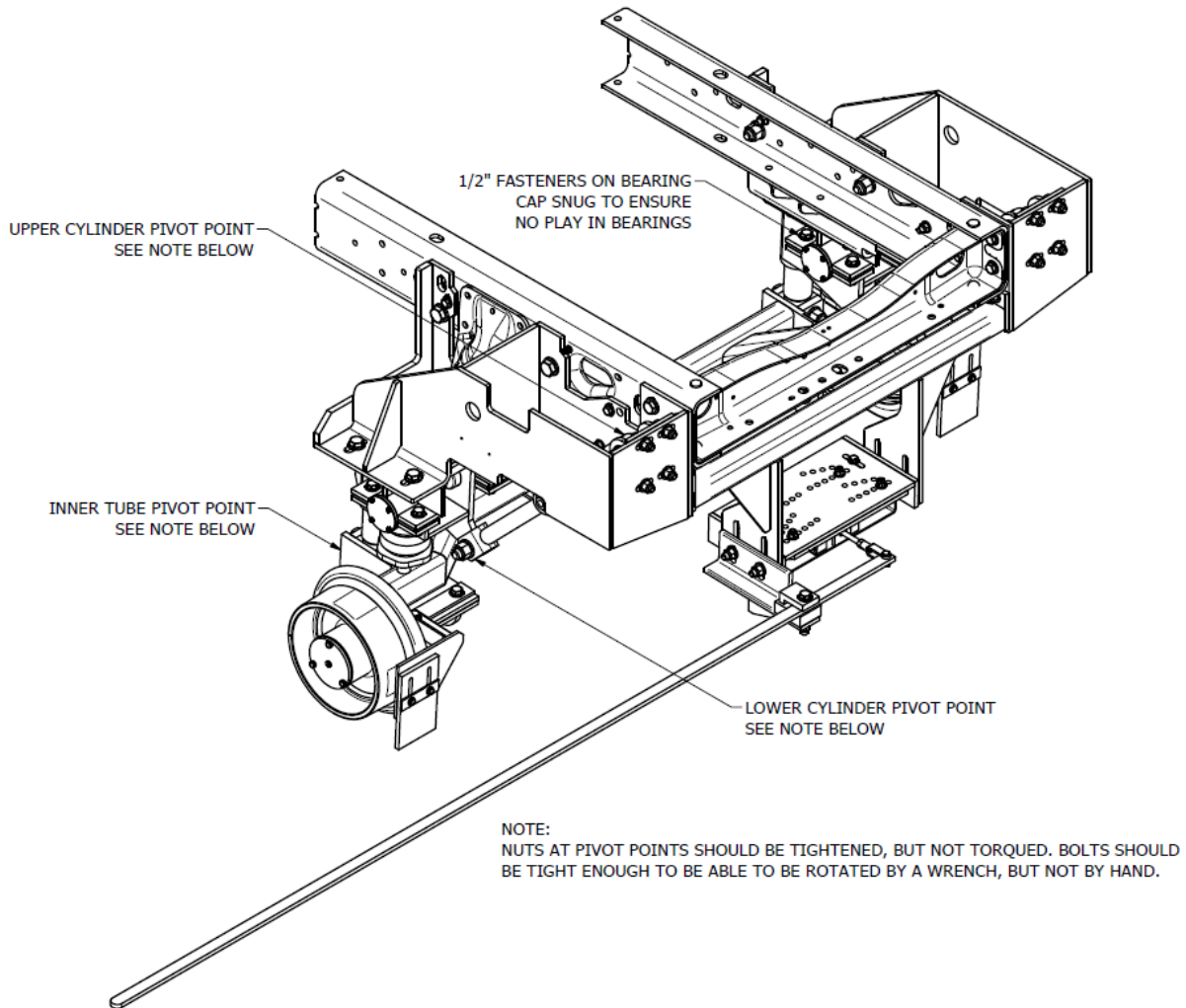
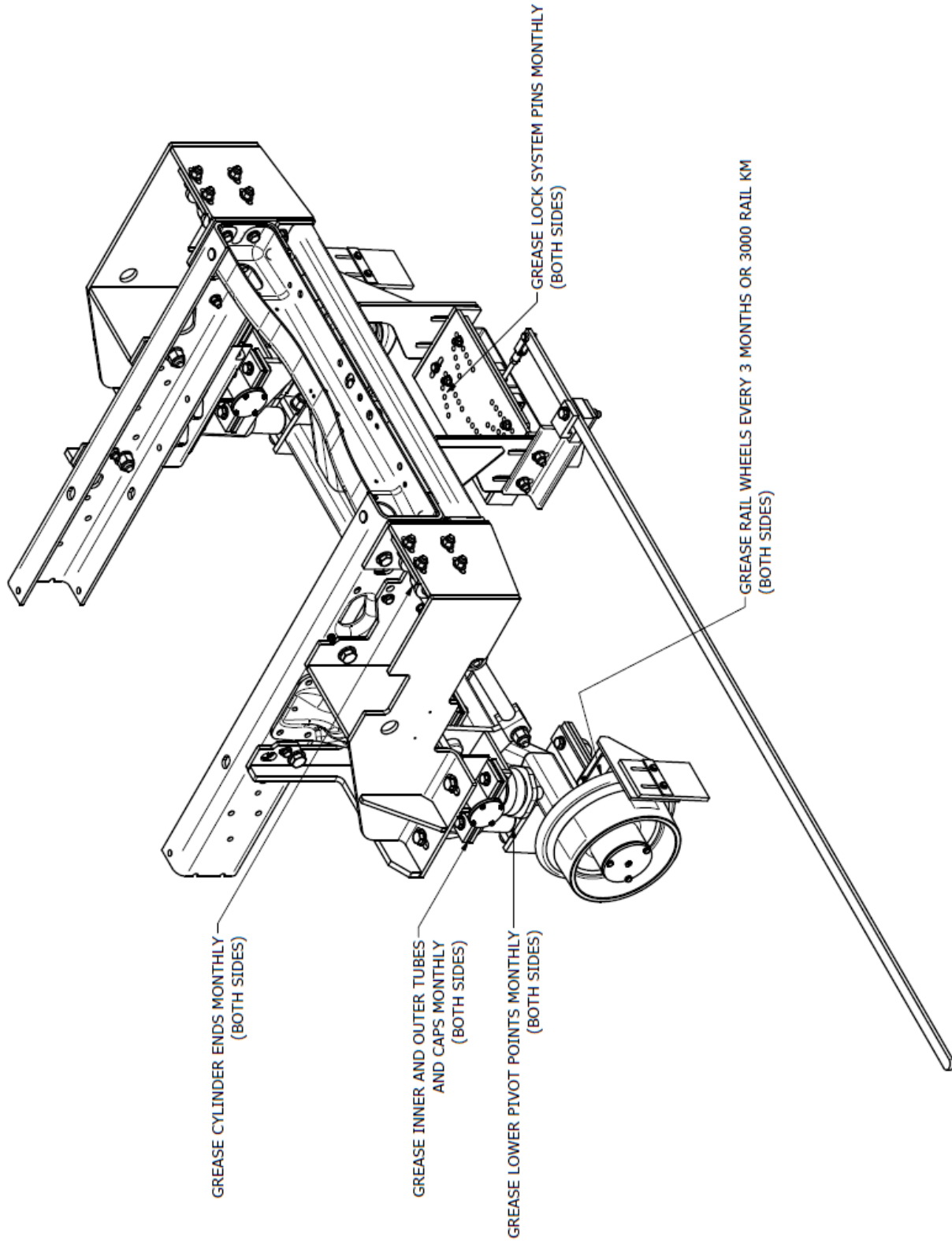

Figure 3  
Non-Standard Fastener Torque Values



**Figure 4**  
**Railgear Lubrication Points**

## RAIL WHEEL BEARING ADJUSTMENT

The rail wheel bearings require periodic adjustment in order to keep the end-play within specification. If the rail wheel bearings are not correctly adjusted, failure may occur that will not be covered under the railgear warranty. Check and adjust the bearing end-play with the railgear in the road position and with the rail wheels free to turn.

Use a magnetic base dial gauge to measure the end-play of each rail wheel bearing. The bearing end-play must be between 0.001" and 0.005". If this is not the case, adjust as follows:

1. Remove the rail wheel hubcap and gasket by removing the three 1/4" bolts and 1/4" lock washers.
2. Remove the spindle nut cotter pin.
3. Ensure that the wheel bearing cavity is full of grease.
4. While rotating the rail wheel forward, torque the spindle nut to 20 ft-lbs. Then loosen the spindle nut and re-torque it to 6 ft-lbs. Re-check and re-adjust the bearing end-play if required. If no torque wrench is available, tighten the spindle nut until the rail wheel is difficult to turn by hand. Then loosen the spindle nut and retighten it just until no looseness can be felt in the bearings. Re-adjust the bearing end-play with a torque wrench as soon as possible.
5. Install a new 3/16" x 2" long cotter pin through the spindle nut. Tighten the spindle nut slightly if needed to insert the cotter pin.
6. Re-install the hubcap and gasket using the 1/4" bolts and new 1/4" lock washers. Blue Loctite can be used on the bolts as an added safety measure. Tighten and torque the 1/4" fasteners to 12 ft-lbs. dry. Do not over torque.

## RAIL SWEEP ADJUSTMENT

The distance between the rail sweep rubber and the rail is adjustable and should be maintained at approximately 1/8". To adjust the rail sweep rubber, with the railgear in the rail position, loosen the two 1/4" fasteners which secure the rail sweep rubber to the rail sweep bracket. Slide the rail sweep rubber up or down for the correct clearance. Tighten and torque the 1/4" fasteners to 12 ft-lbs dry. Do not over torque.

## RAIL WHEEL LOAD ADJUSTMENT

During rail travel, the railgear removes a predetermined portion of the vehicle's load from the vehicle's wheels and carries it on the rail wheels. A minimum amount of load must be maintained on the rail wheels in order to avoid derailment. Likewise, a minimum amount of load must be maintained on the vehicle wheels in order to provide traction for acceleration and braking.

The rail wheel load should be adjusted following the installation of the railgear once the vehicle has had all of its permanent load (service body, crane, welders, etc.) installed. The rail wheel load requires periodic checks; however, it should only require re-adjustment if the railgear is moved, the vehicle equipment is changed, or the vehicle suspension settles or is changed. As non-permanent load is added to and/or removed from the vehicle, the rail wheel load will change also. This is acceptable as long as the weight ratings of the vehicle, axles, wheels, tires and railgear are not exceeded and as long as the minimum rail wheel load is maintained.

The rail wheel load must be a minimum of 800 lbs and is checked as described below using a hydraulic bottle jack equipped with a gauge. If the gauge on the hydraulic bottle jack reads in pounds per square inch (psi), use Table 4 along with the jack bore diameter to convert this reading to pounds (lbs). If the gauge reads in pounds, then no conversion is required.

### Check each rail wheel load as follows:

1. Place the vehicle on a straight and level section of rail with the railgear lowered to the rail position. Ensure the railgear is taking load through the tread of the rail wheel and not on the flange of the rail wheel. The vehicle should only be carrying the permanently attached load (service body, crane, etc.) and any always carried non-attached load (welders, etc.) during this procedure. Do not include the operator or passengers. Ensure the vehicle tires have been inflated to the manufacturer's recommended air pressure and that they are not in contact with any obstructions except the rails.
2. Place the hydraulic bottle jack on a solid surface beneath the rail wheel spindle housing and jack the rail wheel off the rail.
3. Insert a piece of paper between the rail and the rail wheel. Lower the jack until the rail wheel squeezes the paper so that it cannot be pulled out.
4. Slowly jack up the rail wheel while pulling on the paper and observe the jack gauge. When the paper can be pulled out, stop jacking.
5. Record the load or pressure reading on the jack gauge.
6. If necessary, convert the pressure reading to a load reading using the supplied table.

Table 4: Rail Wheel Load vs Jack Pressure and Bore

Jack Pressure (PSI)	Jack Cylinder Bore Diameter (inches)								
	7/8	15/16	1	1 1/16	1 1/8	1 3/16	1 1/4	1 5/16	1 3/8
540	320	370	420	480	540	600	660	730	800
560	340	390	440	500	560	620	690	760	830
580	350	400	460	510	580	640	710	780	860
600	360	410	470	530	600	660	740	810	890
620	370	430	490	550	620	690	760	840	920
640	380	440	500	570	640	710	790	870	950
660	400	460	520	590	660	730	810	890	980
680	410	470	530	600	680	750	830	920	1010
700	420	480	550	620	700	780	860	950	1040
720	430	500	570	640	720	800	880	970	1070
740	440	510	580	660	740	820	910	1000	1100
760	460	520	600	670	760	840	930	1030	1130
780	470	540	610	690	780	860	960	1060	1160
800	480	550	630	710	800	890	980	1080	1190
820	490	570	640	730	820	910	1010	1110	1220
840	510	580	660	740	830	930	1030	1140	1250
860	520	590	680	760	850	950	1060	1160	1280
880	530	610	690	780	870	970	1080	1190	1310
900	540	620	710	800	890	1000	1100	1220	1340
920	550	640	720	820	910	1020	1130	1240	1370
940	570	650	740	830	930	1040	1150	1270	1400
960	580	660	750	850	950	1060	1180	1300	1430
980	590	680	770	870	970	1090	1200	1330	1460
1000	600	690	790	890	990	1110	1230	1350	1480
1020	610	700	800	900	1010	1130	1250	1380	1510
1040	630	720	820	920	1030	1150	1280	1410	1540
1060	640	730	830	940	1050	1170	1300	1430	1570
1080	650	750	850	960	1070	1200	1330	1460	1600
1100	660	760	860	980	1090	1220	1350	1490	1630
1120	670	770	880	990	1110	1240	1370	1520	1660
1140	690	790	900	1010	1130	1260	1400	1540	1690
1160	700	800	910	1030	1150	1280	1420	1570	1720
1180	710	810	930	1050	1170	1310	1450	1600	1750
1200	720	830	940	1060	1190	1330	1470	1620	1780
1220	730	840	960	1080	1210	1350	1500	1650	1810
1240	750	860	970	1100	1230	1370	1520	1680	1840
1260	760	870	990	1120	1250	1400	1550	1700	1870
1280	770	880	1010	1130	1270	1420	1570	1730	1900
1300	780	900	1020	1150	1290	1440	1600	1760	1930
1320	790	910	1040	1170	1310	1460	1620	1790	1960
1340	810	920	1050	1190	1330	1480	1640	1810	1990
1360	820	940	1070	1210	1350	1510	1670	1840	2020
1380	830	950	1080	1220	1370	1530	1690	1870	2050
1400	840	970	1100	1240	1390	1550	1720	1890	2080
1420	850	980	1120	1260	1410	1570	1740	1920	2110
1440	870	990	1130	1280	1430	1590	1770	1950	2140
1460	880	1010	1150	1290	1450	1620	1790	1980	2170
1480	890	1020	1160	1310	1470	1640	1820	2000	2200
1500	900	1040	1180	1330	1490	1660	1840	2030	2230
1520	910	1050	1190	1350	1510	1680	1870	2060	2260
1540	930	1060	1210	1370	1530	1710	1890	2080	2290
1560	940	1080	1230	1380	1550	1730	1910	2110	2320
1580	950	1090	1240	1400	1570	1750	1940	2140	2350
1600	960	1100	1260	1420	1590	1770	1960	2160	2380
1620	970	1120	1270	1440	1610	1790	1990	2190	2410
1640	990	1130	1290	1450	1630	1820	2010	2220	2440
1660	1000	1150	1300	1470	1650	1840	2040	2250	2460
1680	1010	1160	1320	1490	1670	1860	2060	2270	2490
1700	1020	1170	1340	1510	1690	1880	2090	2300	2520
1720	1030	1190	1350	1530	1710	1900	2110	2330	2550
1740	1050	1200	1370	1540	1730	1930	2140	2350	2580

Rail Wheel Load (lbs)

Adjust each rail wheel load as follows:

There are two rubber springs on the railgear located between each railgear outer tube assembly and spring plate. Each spring is held in place by a nylock nut above it and a spring plate with a jam nut below it. The spring plate can be lowered and raised on the threaded rod to correspondingly decrease and increase the rail wheel load.

1. Raise the railgear until the rail wheels are off the rails.
2. Loosen the 1" Nylock nut above each spring and the 1" jam nut under each spring plate.
3. To decrease the load on the rail wheels, lower the spring plates on the threaded rods. To increase the load on the rail wheels, raise the spring plates on the threaded rods. Each side should be adjusted the same amount.
4. Lower the railgear to the rail position and re-check the rail wheel loads. Re-adjust the rail wheel loads if necessary.
5. Raise the railgear until the rail wheels are off the rails. Tighten the 1" jam nut on the threaded rod so that they are tight against the spring plate.
6. Tighten the 1" Nylock nuts above the springs so that the rubber springs are compressed to 3.75".
7. Following the rail wheel load adjustment, the railgear may contact the vehicle if not enough clearance was left during installation. Check the railgear clearance to all vehicle components throughout the full range of railgear and railgear suspension movement. If there is interference with the vehicle exhaust system, it can be bent to fit, ensuring any exhaust system modifications conform to applicable laws and regulations. If there is interference with any other vehicle components, please call G&B Specialties, Inc. for technical assistance.

## RAILGEAR ALIGNMENT

The railgear must be correctly aligned to perform properly, safely, and avoid excessive wear and derailment. The rail wheels can be independently aligned for toe-in/toe-out and the railgear can be adjusted side to side (laterally) on the vehicle. A parallel line system and the following procedure should be used to perform the railgear alignment.

The rail wheel loads should be checked and adjusted, the vehicle should have had a four-wheel alignment (with the complete railgear package installed on the vehicle and any suspension modifications done) and the tires should be properly inflated prior to performing the railgear alignment.

The railgear alignment is done with the vehicle on a straight and level section of rail with the railgear in the rail position and the vehicle wheels pointing straight ahead. The individual rail wheel alignment should be done first, followed by the lateral alignment of the railgear.

Each rail wheel is aligned by loosening the four 1/2" fasteners that secure it to the railgear axle. The rail wheel is then turned into alignment. The four 1/2" fasteners should then be tightened and torqued to 100 ft-lbs dry. Do not over torque.

The railgear is aligned laterally by loosening the eight 5/8" fasteners that secure it to the railgear mounting boxes. The railgear is then moved sideways into alignment. It may be necessary to raise the railgear off the rails to move the railgear side to side. Do not use any force against the railgear guide tubes as this may damage them and restrict suspension movement. The eight 5/8" fasteners should then be tightened and torqued to 150 ft-lbs dry. Do not over torque.

Refer to Figure 5 for alignment measurement and specifications. Use an 18" magnetic straight edge on the back of each rail wheel to measure from.

Following the railgear alignment, the railgear may contact the vehicle if not enough clearance was left during installation. Check the railgear clearance to all vehicle components throughout the full range of railgear and railgear suspension movement. If there is interference with the vehicle bumper, it can be trimmed and reinforced as required. If there is interference with the vehicle exhaust system, it can be bent to fit, ensuring any exhaust system modifications conform to applicable laws and regulations. If there is interference with any other vehicle components, please call G&B Specialties, Inc. for technical assistance.



### RAFNA RAILGEAR ALIGNMENT RACK DATA

GAS OR DIESEL \_\_\_\_\_ VIN# \_\_\_\_\_

VEHICLE MAKE: \_\_\_\_\_ VEHICLE MODEL: \_\_\_\_\_ VEHICLE YEAR: \_\_\_\_\_  
 DOOR STICKER GVWR: \_\_\_\_\_ DOOR STICKER GAWR FRT: \_\_\_\_\_ DOOR STICKER GAWR RR \_\_\_\_\_  
 RAILGEAR S/N: FRT \_\_\_\_\_ RR \_\_\_\_\_ VEHICLE UNIT #,S/N: \_\_\_\_\_  
 RAILGEAR TYPE: \_\_\_\_\_ INSTALLER: \_\_\_\_\_ DATE: \_\_\_\_\_

SET UP PARALLEL STRING LINES  
 A & B MUST BE EQUAL WITHIN 1/32"  
 C & D MUST BE EQUAL WITHIN 1/32"

ADJUST STRING LINES AROUND VEHICLE  
 E, F, G, & H MUST BE EQUAL WITHIN 1/16"  
 I, J, K, & L MUST BE EQUAL WITHIN 1/16"  
 (E, F, G, & H MAY NOT EQUAL I, J, K, & L)

ADJUST RAIL WHEEL ALIGNMENT  
 M & O MUST BE EQUAL WITHIN 1/16"  
 N & P MUST BE EQUAL WITHIN 1/16"  
 Q & S MUST BE EQUAL WITHIN 1/16"  
 R & T MUST BE EQUAL WITHIN 1/16"

ADJUST RAILGEAR LATERAL ALIGNMENT  
 M & O MUST EQUAL N & P WITHIN 1/8"  
 Q & S MUST EQUAL R & T WITHIN 1/8"

ENSURE THAT U & V ARE BETWEEN  
 53- 7/16" AND 53-9/16"

OVER-CENTER ANGLE (DEGREE)  
 FRONT \_\_\_\_\_  
 REAR \_\_\_\_\_

RAIL WHEEL LOADS (LBS)  
 LEFT FRONT \_\_\_\_\_ RIGHT FRONT \_\_\_\_\_  
 LEFT REAR \_\_\_\_\_ RIGHT REAR \_\_\_\_\_

RAIL WHEEL FLANGE TO GROUND CLEARANCE  
 LEFT FRONT \_\_\_\_\_ RIGHT FRONT \_\_\_\_\_  
 LEFT REAR \_\_\_\_\_ RIGHT REAR \_\_\_\_\_

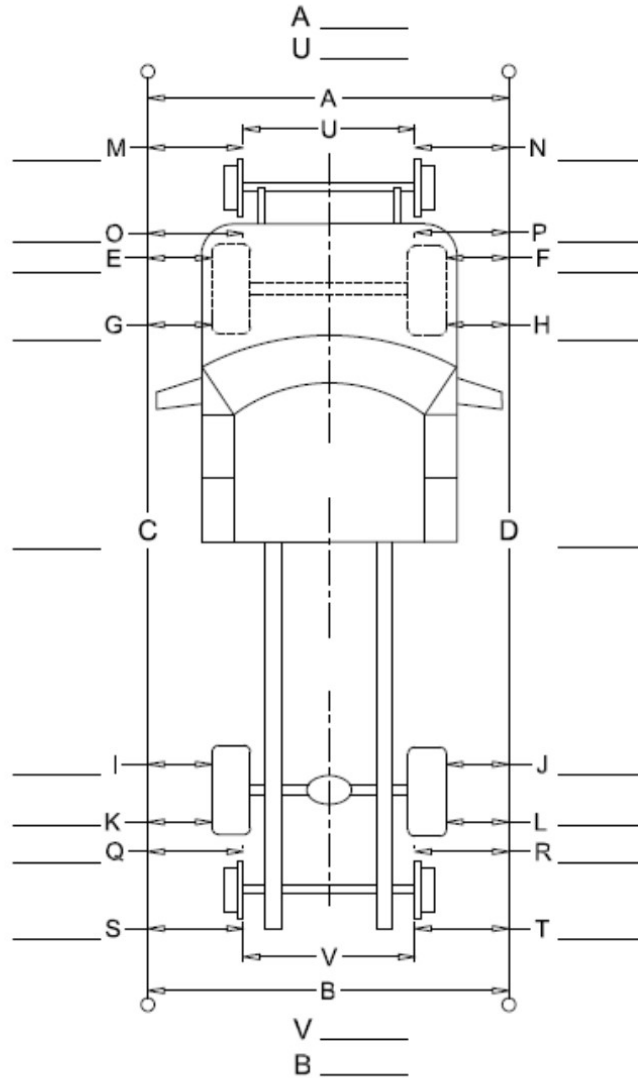

MOUNTING HEIGHT FRONT: \_\_\_\_\_ MOUNTING HEIGHT REAR: \_\_\_\_\_  
**STOCK** TURNING DIAMETER: \_\_\_\_\_ **MODIFIED** TURNING DIAMETER: \_\_\_\_\_  
**OEM:** VEHICLE WEIGHT: \_\_\_\_\_ FRONT GAWR: \_\_\_\_\_ REAR GAWR: \_\_\_\_\_  
**MODIFIED:** VEHICLE WEIGHT: \_\_\_\_\_ FRONT GAWR: \_\_\_\_\_ REAR GAWR: \_\_\_\_\_

**FAX COMPLETED FORM TO JAKE SANUTE AT FAX # 570-802-0491**

MAY 31, 2018 REV "D"

**Figure 5: Railgear Alignment Rack**

**RAFNA RAILGEAR PORTABLE ALIGNMENT DATA**

GAS OR DIESEL \_\_\_\_\_ VIN# \_\_\_\_\_

VEHICLE MAKE: \_\_\_\_\_ VEHICLE MODEL: \_\_\_\_\_ VEHICLE YEAR: \_\_\_\_\_  
 DOOR STICKER GVWR: \_\_\_\_\_ DOOR STICKER GAWR FRT: \_\_\_\_\_ DOOR STICKER GAWR RR \_\_\_\_\_  
 RAILGEAR S/N: FRT \_\_\_\_\_ RR \_\_\_\_\_ VEHICLE UNIT #, S/N: \_\_\_\_\_  
 RAILGEAR TYPE: \_\_\_\_\_ INSTALLER: \_\_\_\_\_ DATE: \_\_\_\_\_

ADJUST RAILGEAR LATERAL ALIGNMENT  
 A MUST EQUAL B WITHIN 1/8"  
 C MUST EQUAL D WITHIN 1/8"

ENSURE THAT U & V ARE BETWEEN  
 53- 7/16" AND 53-9/16"

OVER-CENTER ANGLE (DEGREE)  
 FRONT \_\_\_\_\_  
 REAR \_\_\_\_\_

RAIL WHEEL LOADS (LBS)  
 LEFT FRONT \_\_\_\_\_ RIGHT FRONT \_\_\_\_\_  
 LEFT REAR \_\_\_\_\_ RIGHT REAR \_\_\_\_\_

RAIL WHEEL FLANGE TO GROUND CLEAR-  
 ANCE  
 LEFT FRONT \_\_\_\_\_ RIGHT FRONT \_\_\_\_\_  
 LEFT REAR \_\_\_\_\_ RIGHT REAR \_\_\_\_\_

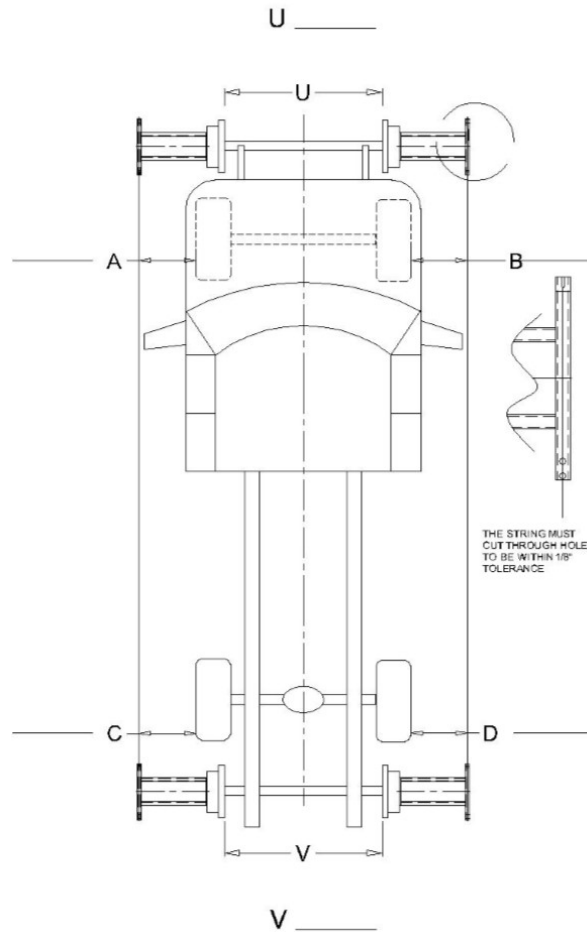

MOUNTING HEIGHT FRONT: \_\_\_\_\_ MOUNTING HEIGHT REAR: \_\_\_\_\_  
**STOCK** TURNING DIAMETER: \_\_\_\_\_ **MODIFIED** TURNING DIAMETER: \_\_\_\_\_  
**OEM:** VEHICLE WEIGHT: \_\_\_\_\_ FRONT GAWR: \_\_\_\_\_ REAR GAWR: \_\_\_\_\_  
**MODIFIED:** VEHICLE WEIGHT: \_\_\_\_\_ FRONT GAWR: \_\_\_\_\_ REAR GAWR: \_\_\_\_\_

**FAX COMPLETED FORM TO JAKE SANUTE AT FAX # 570-802-0491**

MAY 31, 2018 REV B

**Figure 6: Railgear Alignment Portable**

## RAILGEAR LOCK SYSTEM ADJUSTMENT PROCEDURE

The rear railgear lock system provides a mechanical locking mechanism to hold the railgear axle in the road position. For the system to function properly, the contact surface of the angle plate on the axle and the top surface of the locking pins must have a contact length of approximately 3/4" to 7/8" as shown. If these criteria are not met, the following procedure can be followed:

1. Raise the railgear so that the lock angle on the rear axle is parallel to the ground. Support the railgear axle and the lock-up system. **\*The railgear may not be fully retracted. The railgear should rotate up past parallel for the lock-up to work properly\***
2. Remove lock-up cover (if equipped).
3. Loosen the four 1/2" fasteners that secure the lock-up support to the lock-up frame.
4. Adjust the lock-up support and/or rear railgear up or down accordingly so that the pin and the contact surface of the angle plate are parallel. Tighten but do not torque the four 1/2" fasteners.
5. Remove the four inside 3/8" fasteners that secure the lock-up plate to the lock-up support.
6. Loosen the two outside 3/8" fasteners that secure the lock-up plate to the lock-up support.
7. Adjust the lock-up plate in or out accordingly so that the contact surface of the angle plate and the top surface of the lock pins have a contact length of approximately 3/4" to 7/8".
8. The holes in the lock-up plate and the lock-up support allow for horizontal adjustment in 1/8" increments. Align the closest set of holes that will allow a contact length of approximately 3/4" to 7/8".
9. Re-install the four inside 3/8" fasteners that secure the lock-up plate to the lock-up support, that were removed in step #5 above. **Tighten but do not torque at this time.**
10. Retract the lock pins and lower the railgear. Raise the railgear and ensure that the lock system has been properly adjusted and functioning properly and that there are no interferences between lock-up and railgear axle.
11. Repeat the above steps as necessary.
12. Tighten two outside 3/8" fasteners that secure the lock-up plate to the lock-up support.
13. **Torque the 3/8" fasteners to 40 ft-lbs dry. Do not over torque.**

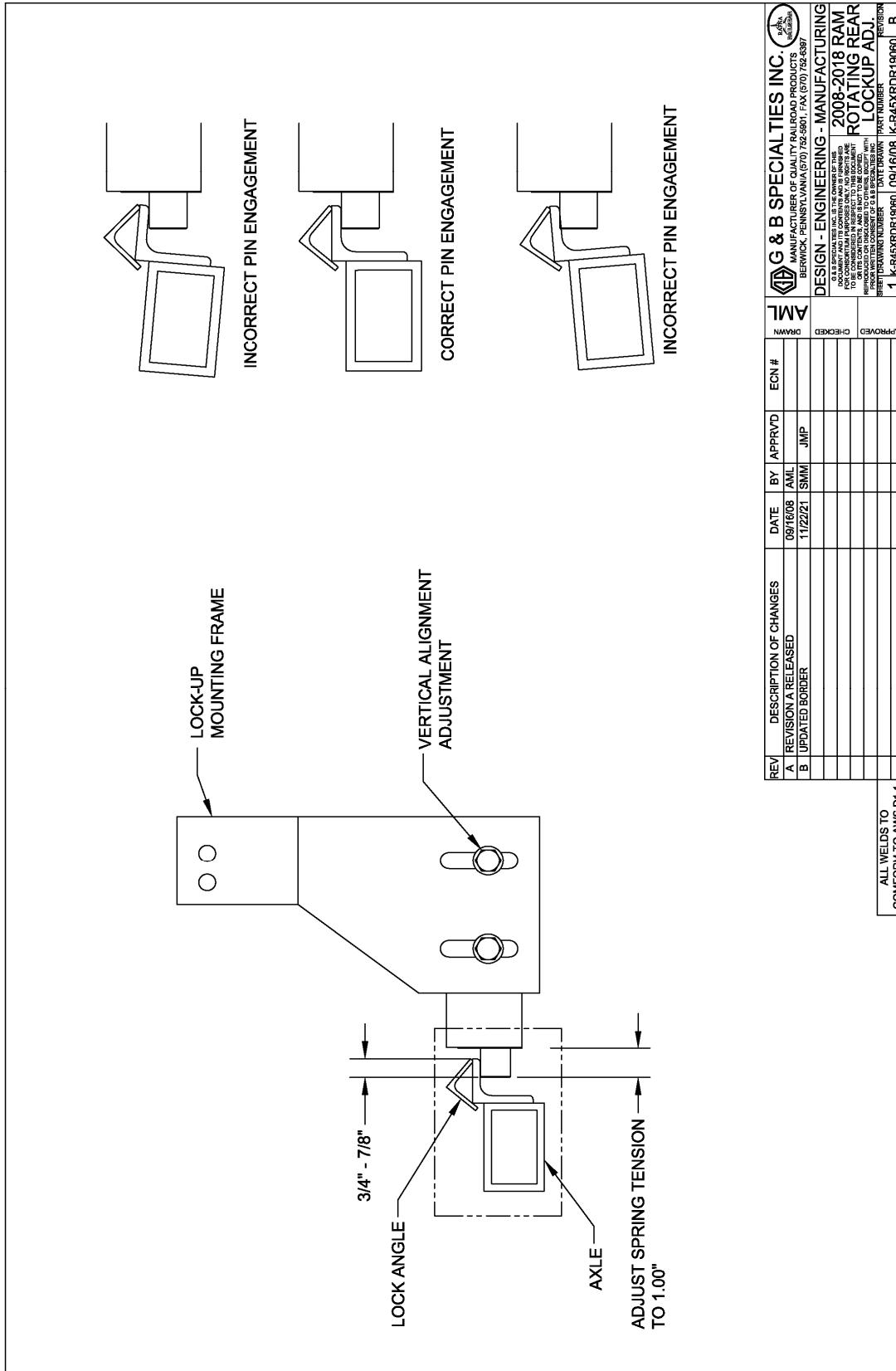

Figure 7

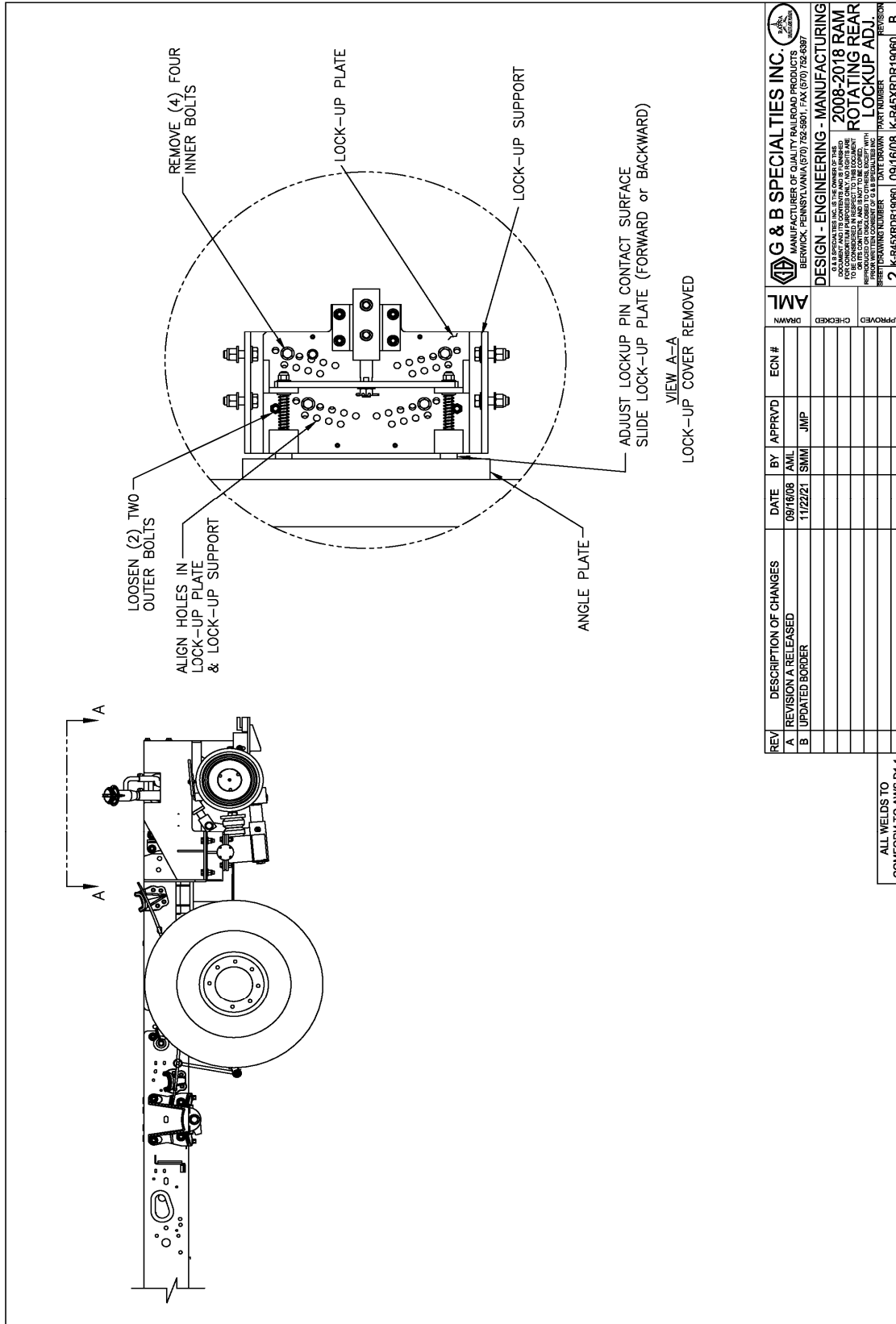

Figure 8

**WHEEL WEAR STANDARDS AND RECOMMENDATIONS**

At the present time, G&B produces 8", 10", 12", 14", and 16" steel wheels. Each size has a different flange and tread thickness, which dictates the allowable wear. Although the following numbers are recommended limits, risk of failure is increased when not followed. Rail gauge can be supplied by G&B Specialties for 8", 10", 12", 14", and 16" rail wheels. They are used as go/no go gauges. When placed on rail wheels they will indicate how much wear is still permissible or if the rail wheels need to be replaced.

The gauge for the R-450 model railgear can be ordered using the following part number; S-001200

- Rail wheel failure can result in equipment damage or failure, personal injury, or death.

**Flange Wear Limits:**

The maximum flange wear is indicated on the rail wheel gauge. When the gauge is placed on the rail wheel, if a gap is seen between the gauge and the maximum flange wear line, the rail wheel needs to be replaced.

**Tread Wear Limits:**

For tread wear, use the following chart in conjunction with the appropriate rail wheel gauge.

NOMINAL RAIL WHEEL DIAMETER (INCHES)	MIN. ALLOWABLE WHEEL DIAMETER (INCHES)
10	9 3/4

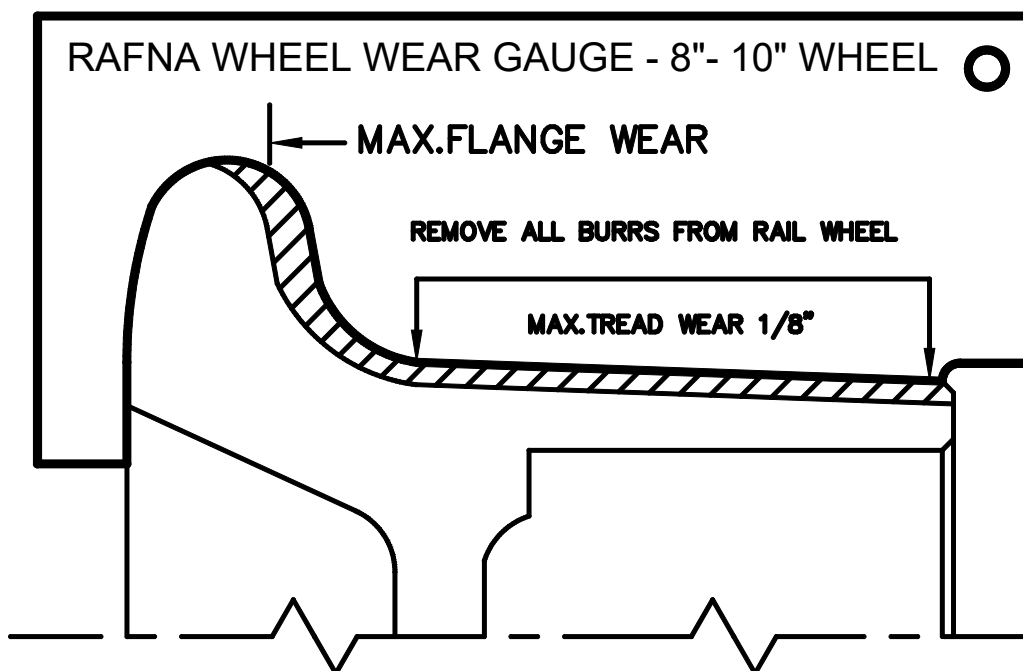

## PARTS OF R-450 ROTATING REAR RAILGEAR KIT

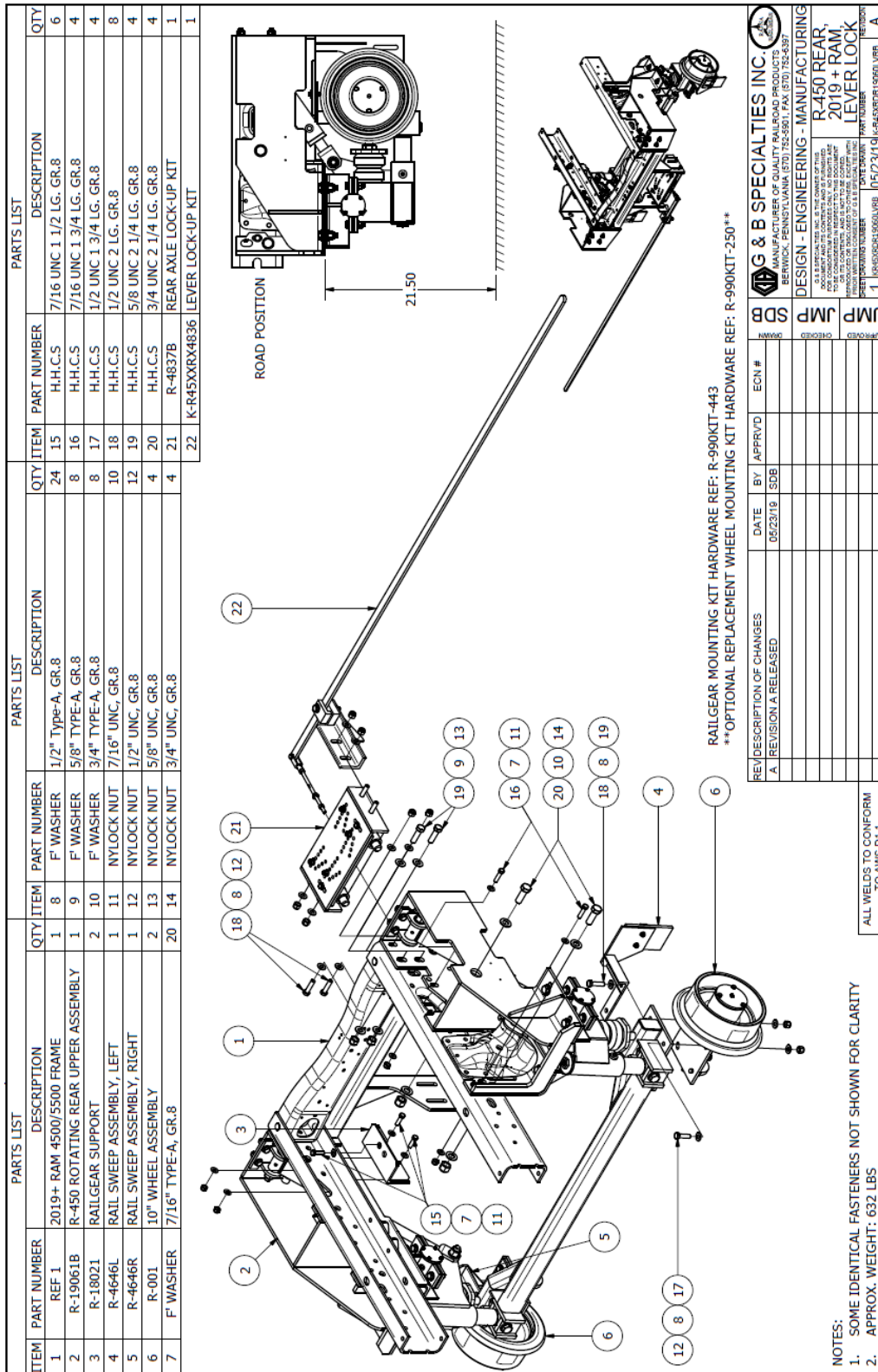

Figure 9

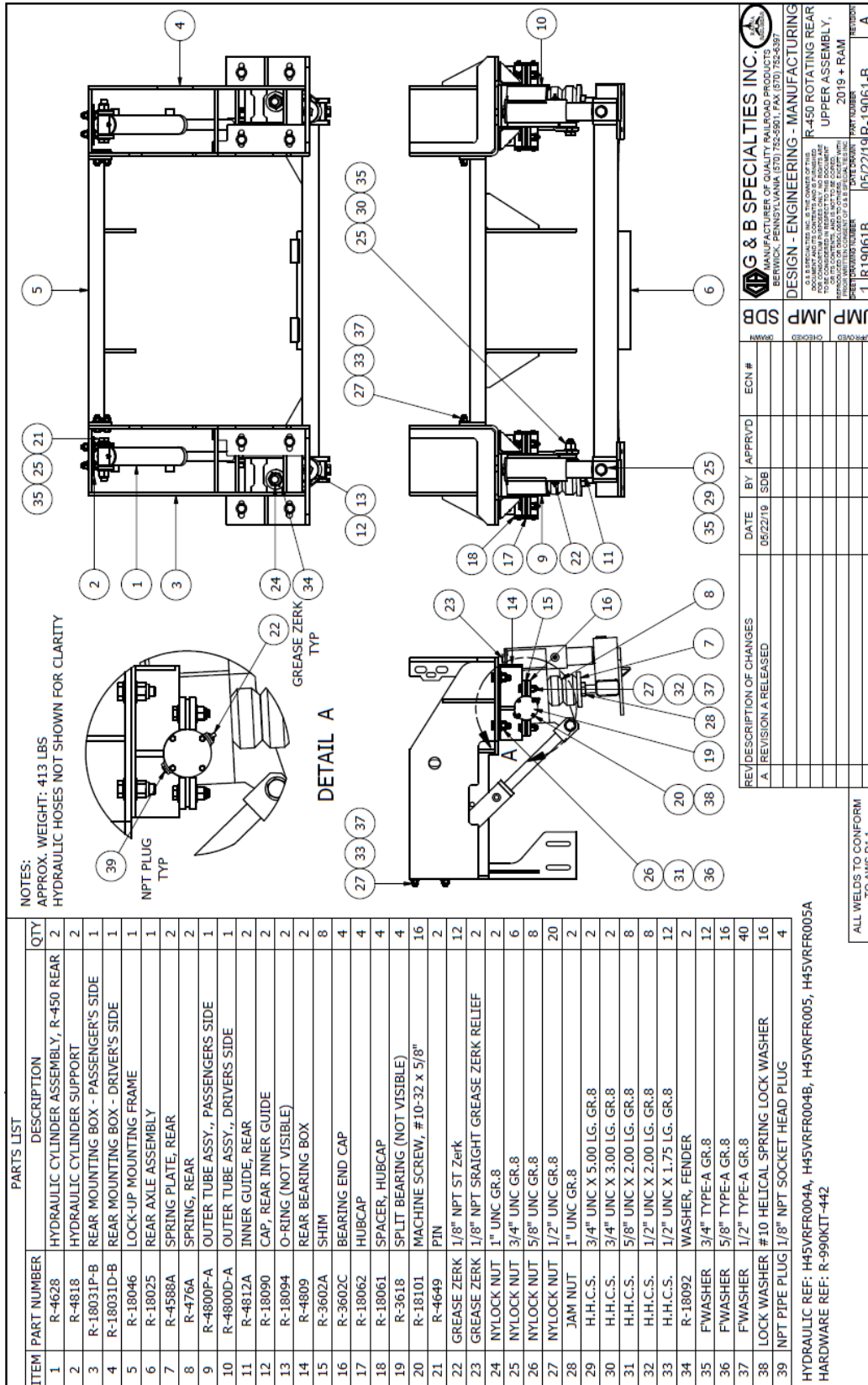

Figure 10



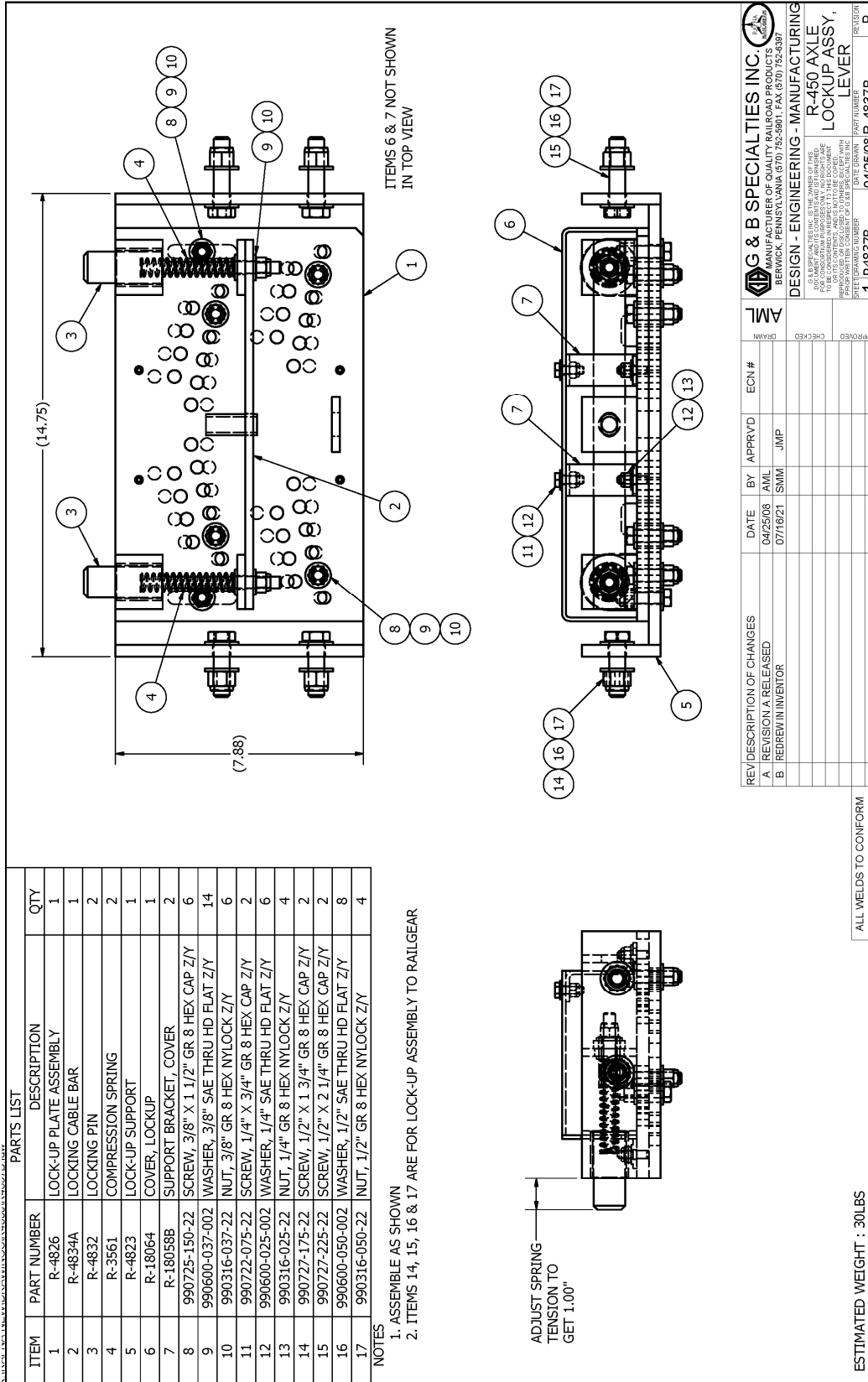

Figure 11

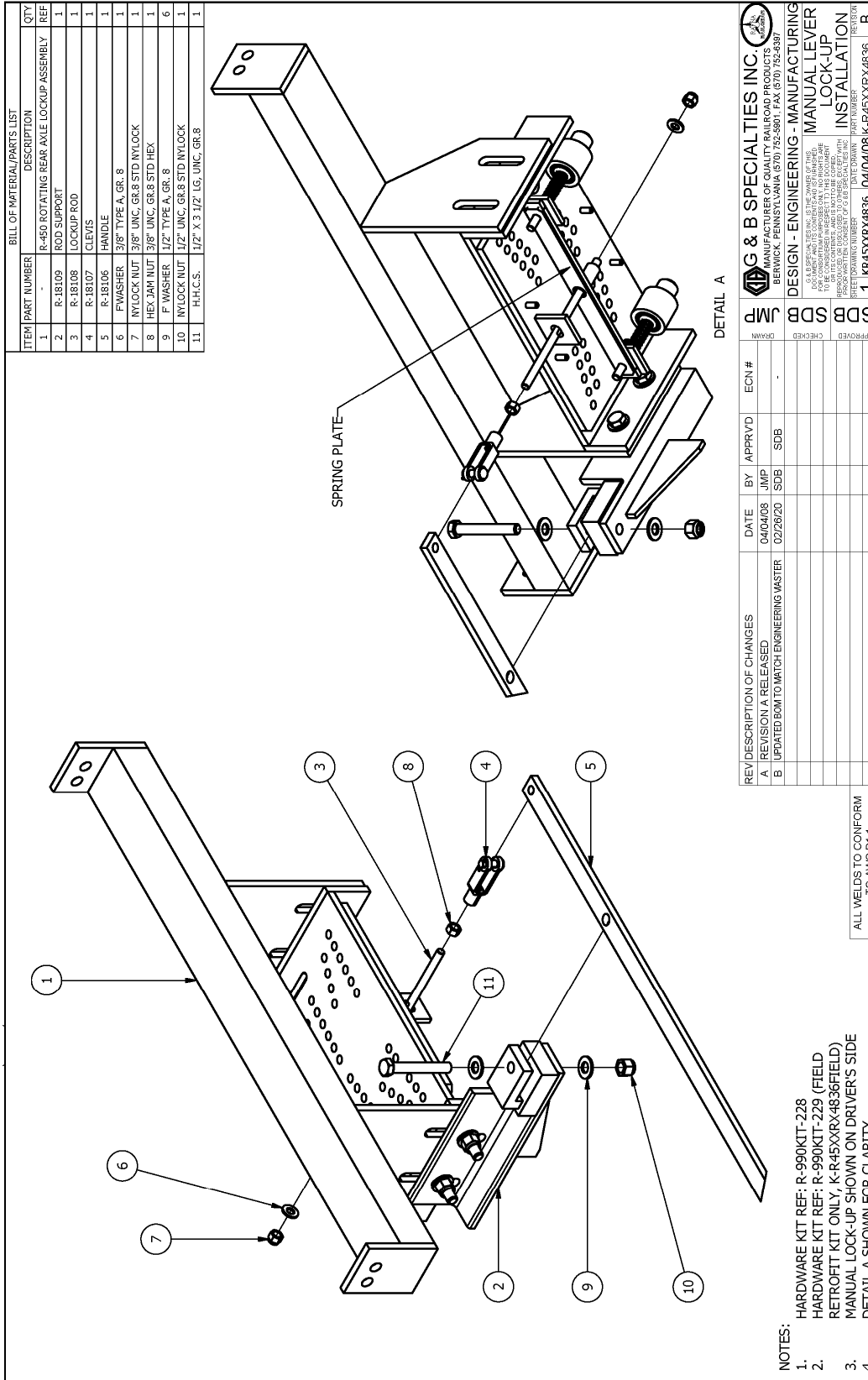

Figure 12

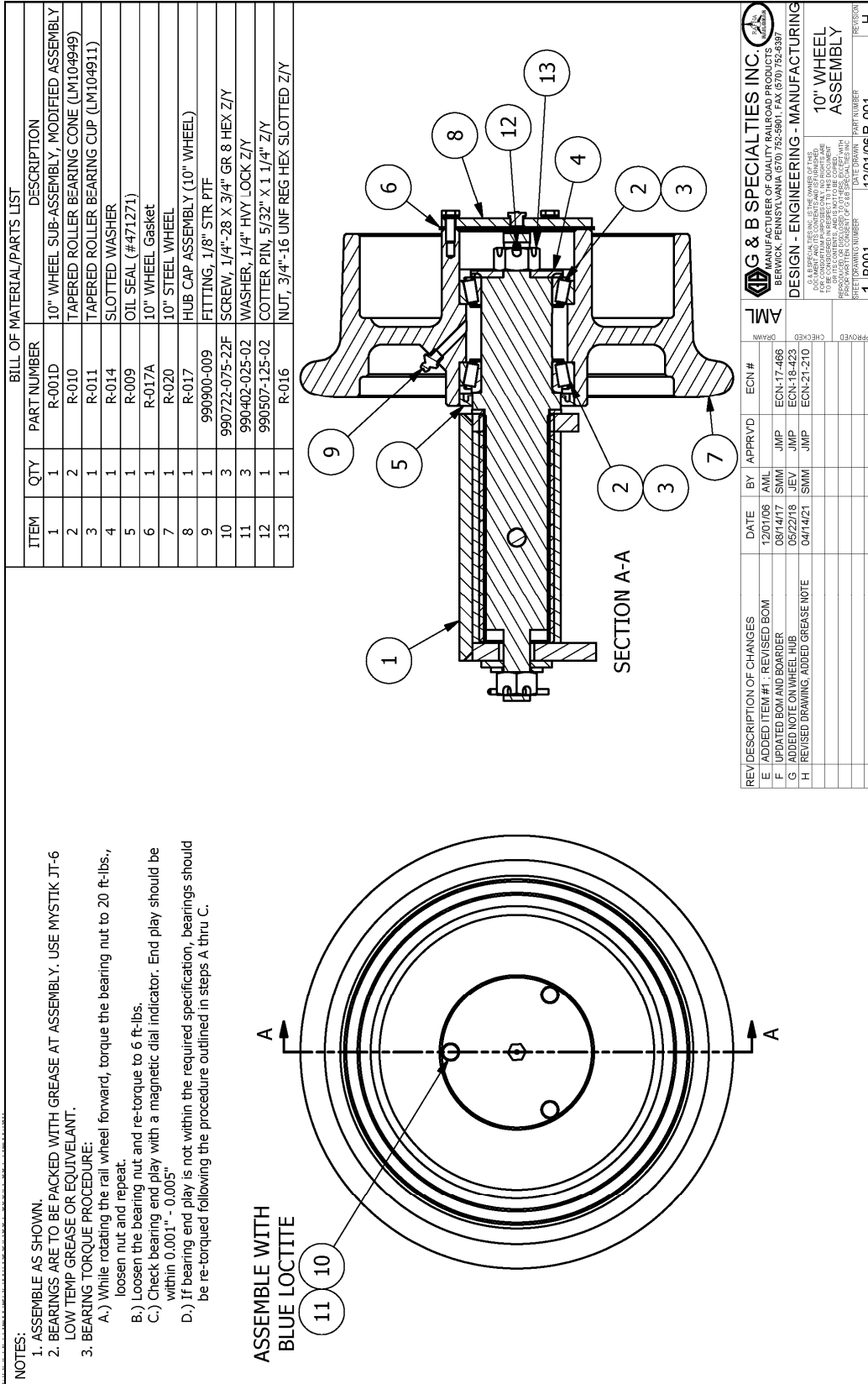

Figure 13

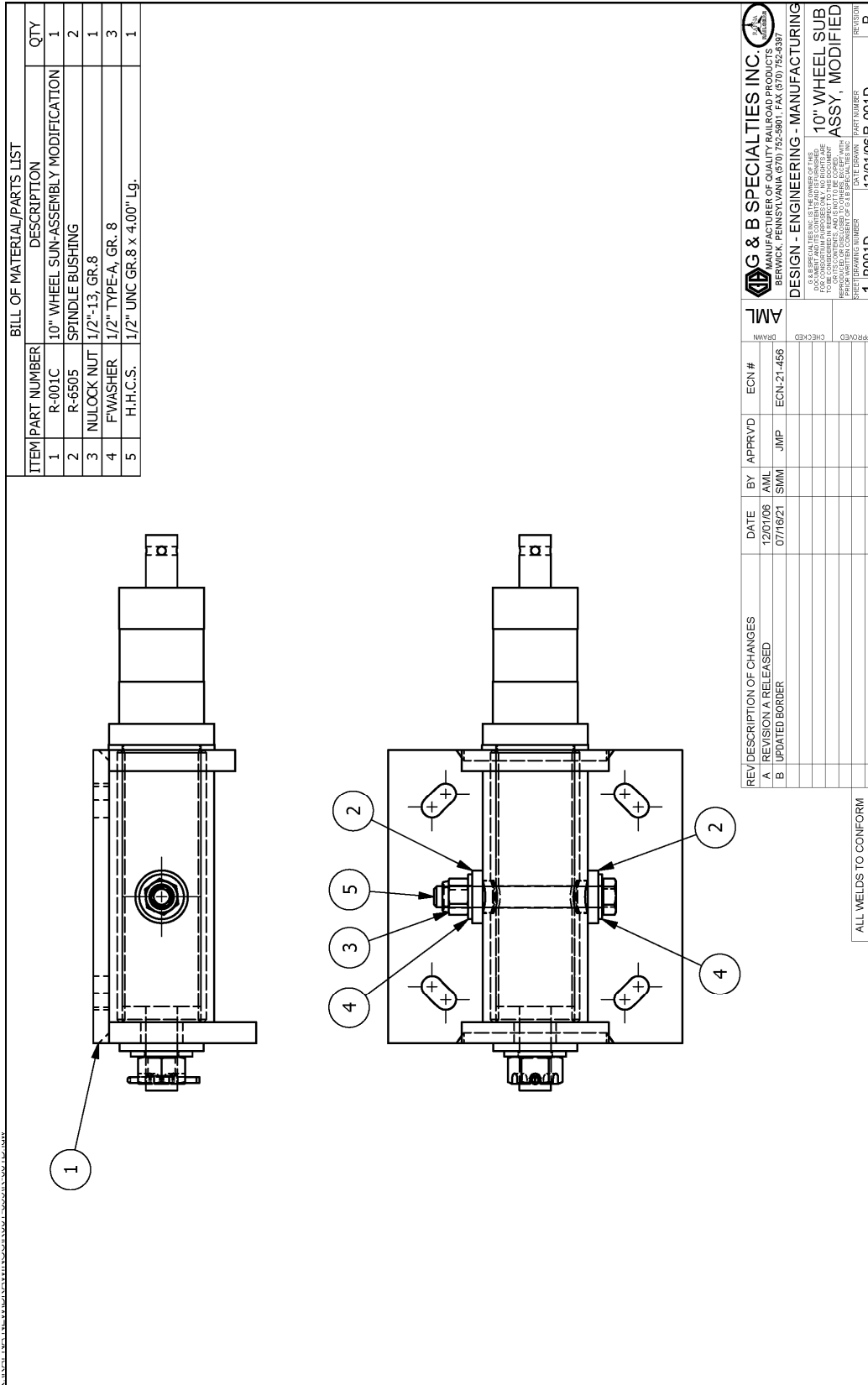

Figure 14

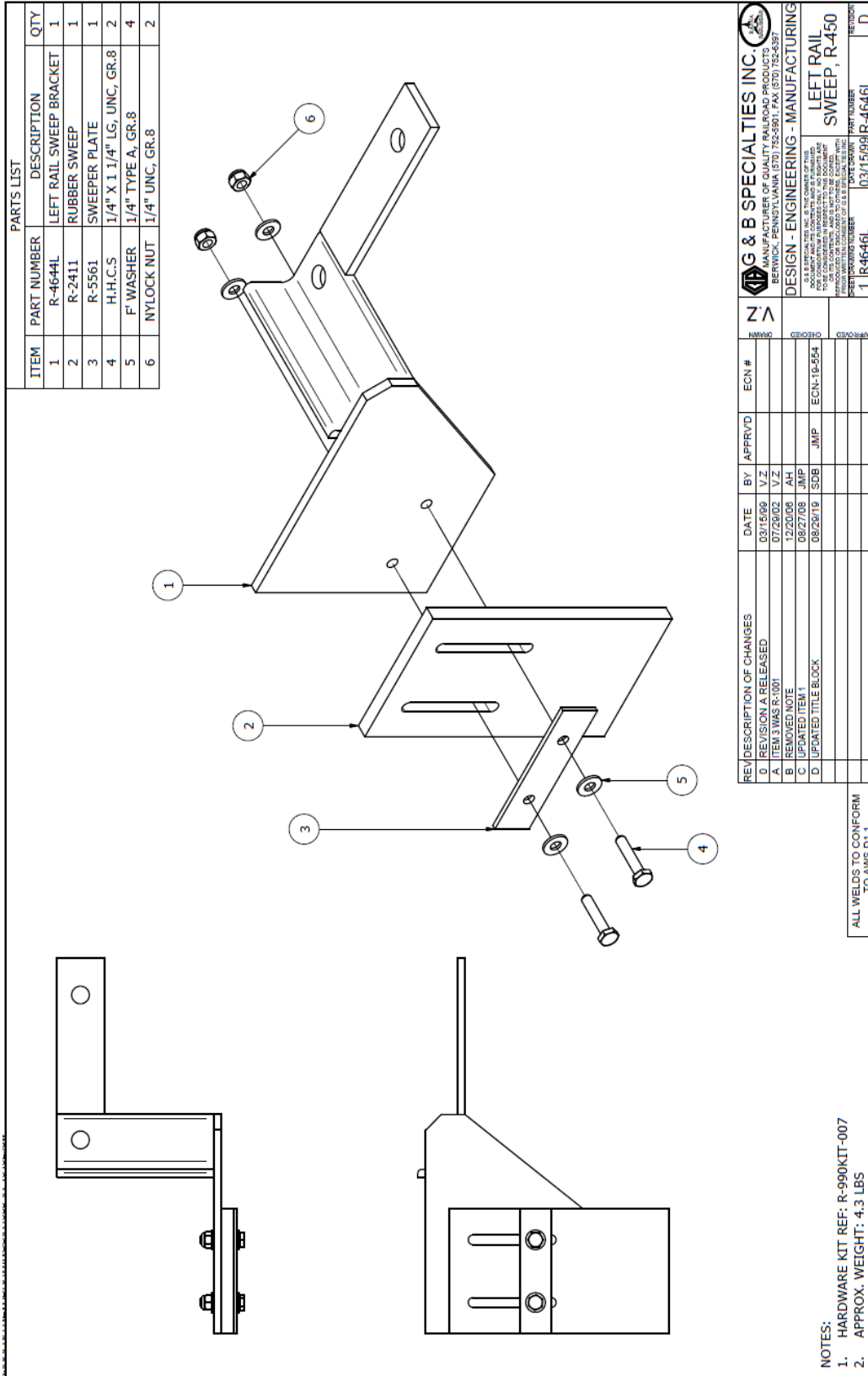

Figure 15





