

INSTALLATION OF R-650 AIR BRAKE KIT

SAFETY PRECAUTIONS

If any installation problems are encountered, please call G&B Specialties, Inc. for technical assistance before continuing with the installation process.



- Failure to heed to any of the following warnings could result in severe bodily injury and/or equipment damage.
- Read and understand this manual completely before attempting installation of the equipment.
- Installation instructions provided below only address the G&B Specialties railgear equipment. Applicable railway company procedures and policies must be adhered to.
- Before performing any work under the vehicle or railgear, ensure the engine is turned off and the parking brake is set.
- Use only Department of Transportation (DOT) approved air brake components when tapping into the vehicle's brake system.
- Use pipe thread sealer on all NPT connections to prevent leaks.
- It is the sole responsibility of the installer to ensure that the modified vehicle and railgear air brake systems comply with the Federal Motor Vehicle Safety Standards regulation #121 (FMVSS-121) and the Canadian Motor Vehicle Safety Standards regulation #121 (CMVSS-121). The modification to the vehicle's brake system must also comply with any federal, state/provincial, and local regulations. Failure to do so may affect the vehicle's braking ability.

INSTALLATION PROCEDURE

The following procedure details the installation of the Air Brake Kit on either the front or rear railgear. The hardware required for this installation is listed in Table 1. All necessary air brake hoses and fittings are to be supplied by the installer.

Table 1: Air Brake Kit Installation Parts

Part Number	Description	Quantity
R-22207D	Brake Assy, Drivers Side	1
R-22207P	Brake Assy, Passengers Side	1
S-006001	Control Valve	1
S-006002	Synchro Valve	1
S-006003	Pressure Reduction Valve	1
S-006004	R-12 Relay Valve	1
S-006006	On/Off Plate	1
R-8594	Ball Valve	1
HY-24ST-02	1/8" NPT Plug	1
HY-24ST-12	3/4" NPT Plug	1
HY-24SA-04	1/4" Male NPT Hydraulic Adapter	2

1. Ensure that the vehicle's parking brake is engaged and that the vehicle is blocked from rolling, then drain the vehicle's air system.
2. Install and weld the brake assemblies to the front railgear axle as shown.
3. The rear railgear unit is shipped from the factory with the brake assemblies pre-installed.
4. Choose an appropriate location within the vehicle's cab and install the air brake control valve with the accompanying on/off plate.
5. Fasten the synchro valve delivery port to the pressure reduction valve supply port using one of the two supplied 1/4" male NPT hydraulic adapters. Fasten the pressure reduction valve delivery port to the relay valve control port using the other supplied 1/4" male NPT hydraulic adapter.
6. Choose an appropriate location on the vehicle or railgear as close as possible to the railgear air brake assemblies to mount these valves and install using the mounting bracket supplied with the relay valve. Ensure that the exhaust ports of the valves are pointing downward.
7. Turn the ball valve to the "off" position and install it directly onto a free port on the vehicle's air tank using an appropriate DOT-approved air brake fitting.

8. Using appropriate DOT-approved air brake hose and fittings connect the control valve supply port to a constant 125 PSI air supply on the vehicle. This can be done by tapping into a constant 125 PSI line or by a "T" fitting off the previously installed ball valve.
9. Connect one of the control valve's delivery ports to the synchro valve control port using appropriate DOT-approved air brake hose and fittings. Plug the unused delivery port of the control valve using the supplied 1/8" plug.
10. **For front railgear brakes only:** Locate the vehicle's front brake quick release valve air supply line. Using appropriate DOT-approved air brake hose and fittings, "T" into this supply line as close to the vehicle cab and the air brake control valve as possible and connect the hose to the synchro valve supply port.
11. **For rear railgear brakes only:** Locate the vehicle's rear brake relay valve control line. Using appropriate DOT-approved air brake hose and fittings, "T" into this control line and connect the hose to the synchro valve supply port.
12. Connect the unused port of the ball valve to one of the two relay valve supply ports using appropriate DOT-approved air brake hose and fittings. Using the supplied 3/4" plug, plug the unused relay valve supply port.
13. Connect each of the two air brake actuators to the delivery ports of the relay valve using appropriate DOT-approved air brake hoses and fittings.
14. Ensure that the air brake hoses are clear of any hot and/or sharp edges. Tie back the air brake hoses to the railgear and/or vehicle frame, ensuring that there is enough slack in the hoses to accommodate the movement of the railgear.
15. Turn "on" the ball valve and leave it in the "on" position.
16. Refer to the Air Brake Kit Operation, Parts and Service Manual to adjust the air brake shoe clearance.
17. Re-charge the vehicle's air brake system, turn on the air brake control valve, and apply the vehicles brakes repeatedly while checking for air leaks.
18. Statically test the railgear air brake system function. With the air brake control valve in the "On" position the railgear air brakes should function together with the vehicle's brakes. With the air brake control valve in the "Off" position the railgear air brakes should be inactive when the vehicle's brakes are applied and released.
19. Raise the railgear to the road position. Ensure that the railgear is locked in place.

20. During final rail testing of the vehicle, the pressure reduction valve can be adjusted to vary the braking effort to reduce rail wheel skid or increase braking force. Refer to the Operation, Service and Parts Manual for this adjustment.

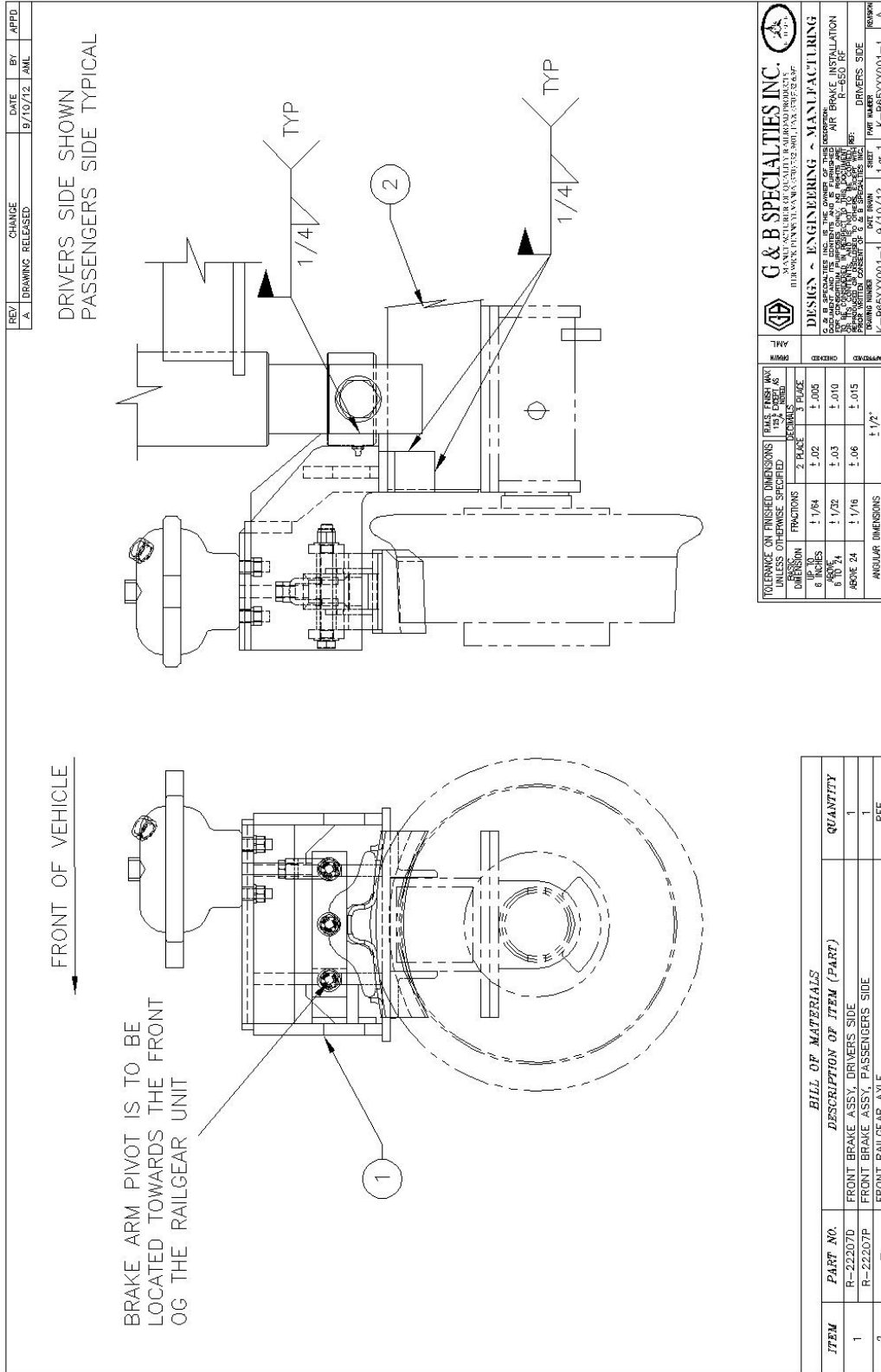

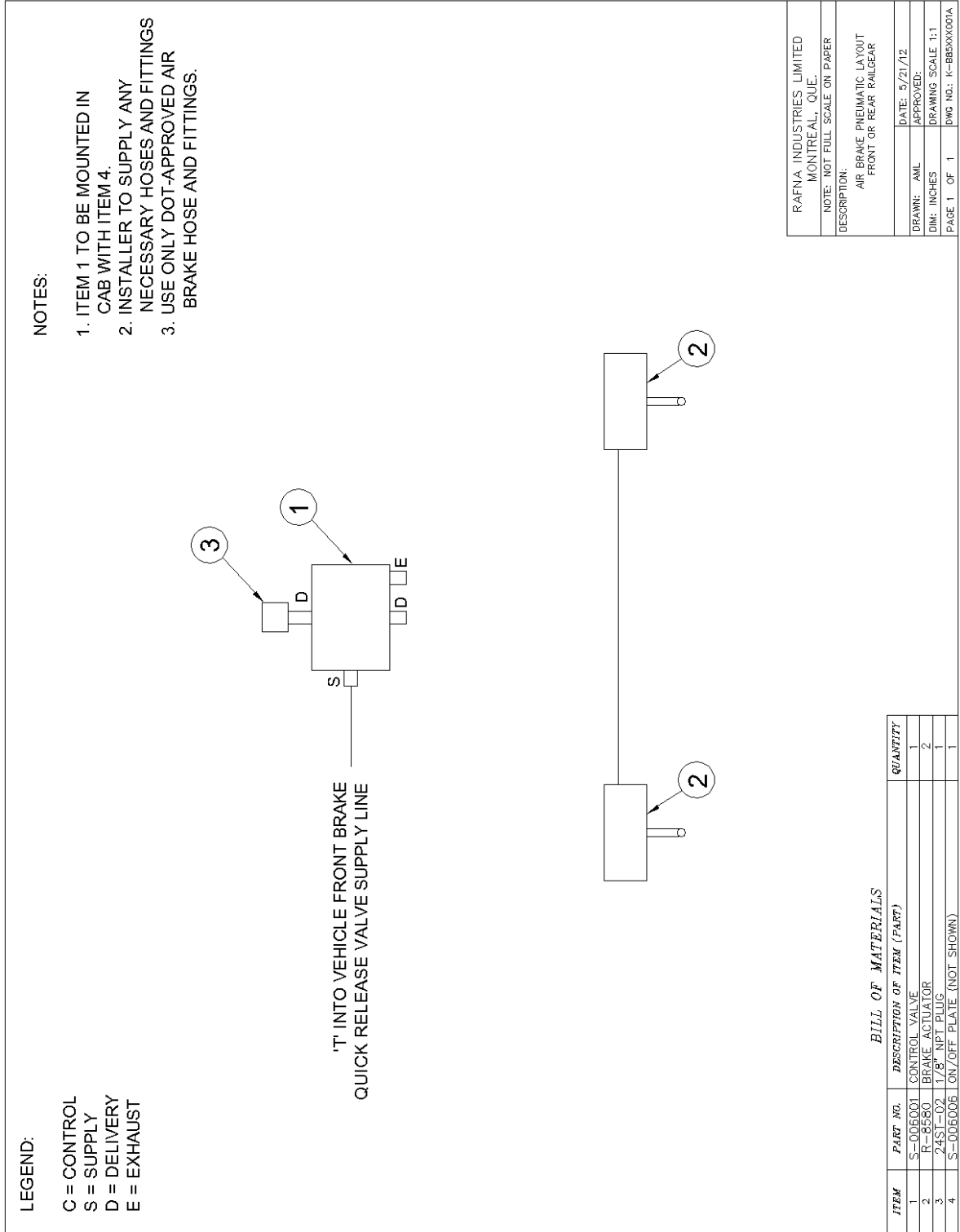

For Brake Isolation

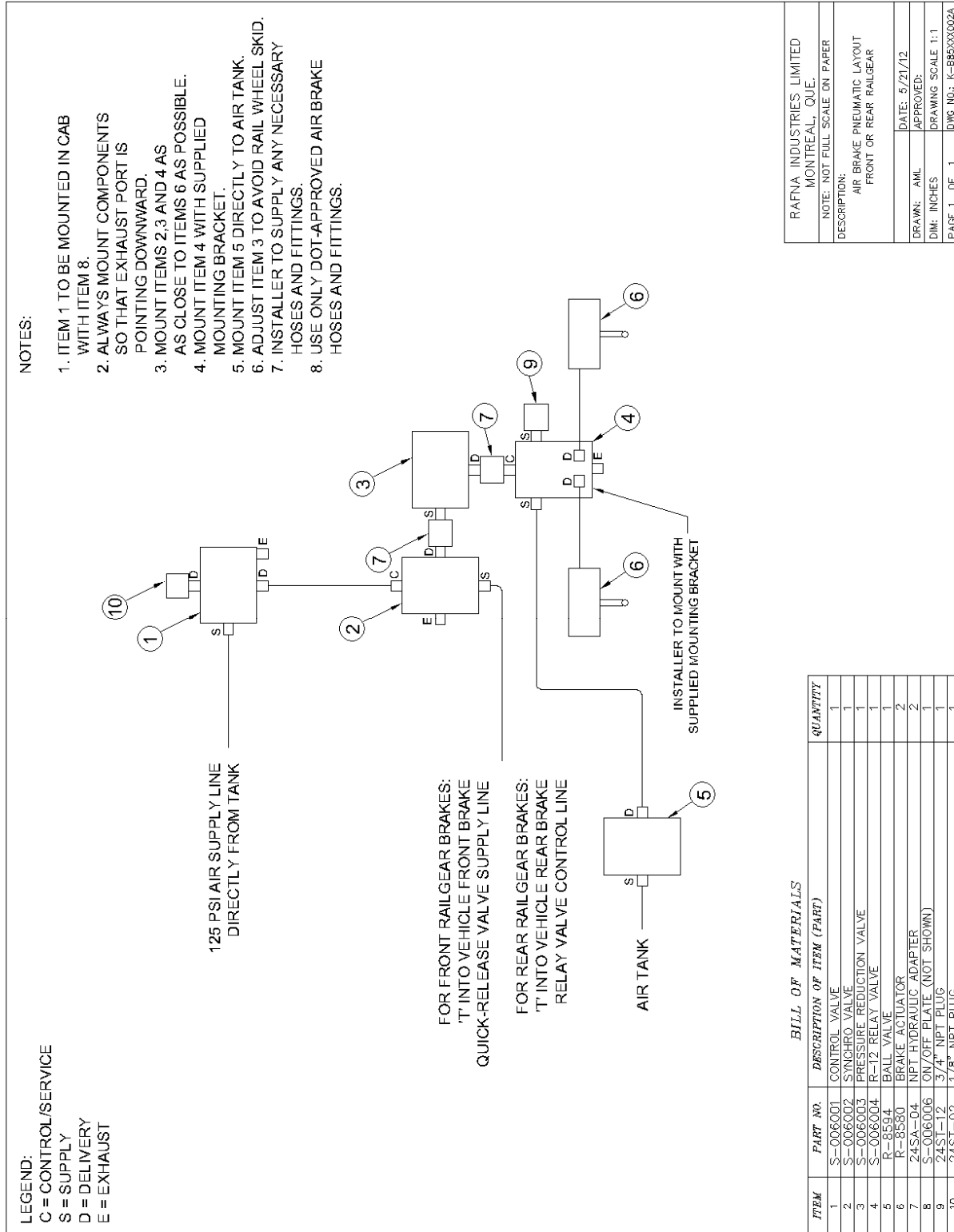

For Brake Isolation / Synchronization

OPERATION, SERVICE AND PARTS OF AIR BRAKE KIT

SAFETY PRECAUTIONS

If any operating, service or parts problems are encountered, please call G&B Specialties, Inc. for technical assistance.



- Failure to heed to any of the following warnings could result in severe bodily injury and/or equipment damage.
- Read and understand this manual completely before attempting operation of the railgear-equipped vehicle.
- Operating instructions provided below only address the G&B Specialties railgear equipment. Applicable railway company procedures and policies must be adhered to.
- Railway company rules governing rail travel must be observed at all times.
- Before performing any work under the vehicle or railgear, ensure the engine is turned off and the parking brake is set.
- Ensure all body parts and loose clothing are clear of any moving parts of the railgear. Be aware of all pinch points.
- Despite the added braking power provided by the railgear air brakes, braking distance while on rail is greater than when on road.
- Do not turn the air brake control valve "On" or "Off" while the vehicle service brakes are applied.
- Never operate the vehicle if the Gross Vehicle Weight Rating (GVWR), Gross Axle Weight Rating Front or Rear (GAWR), or the wheel or tire load ratings are exceeded.

OPERATION OF AIR BRAKE KIT

With the air brake kit installed on this vehicle, it may be operated as normal, however the railgear air brakes must be turned "Off" during road travel and "On" during rail travel. The railgear air brake kit provides additional braking power when on rail. Braking distance on rail is much greater than when on road and will be adversely affected by inclement weather.

Never operate the vehicle if the Gross Vehicle Weight Rating (GVWR), Gross Axle Weight Rating Front or Rear (GAWR), or the wheel or tire load ratings are exceeded.

A dash mounted railgear air brake control valve is provided to turn "Off" and isolate the railgear air brakes from the vehicle's air brakes while on road. When travelling on rail, with the air brake control valve in the "On" position, the railgear air brakes act together with the vehicle's air brakes to provide added braking power through the rail wheels.

To Operate the Vehicle on Road:

1. Engage the vehicle parking brake and release the vehicle service brakes.
2. Turn the dash mounted railgear air brake control valve to the "Off" position. **Do not turn the control valve "Off" while the vehicle service brakes are applied.**
3. Apply the vehicle service brakes and release the vehicle parking brakes.
4. Proceed with road travel. The railgear air brakes will remain in-active.

To Operate the Vehicle on Rail:

1. Engage the vehicle parking brake and release the vehicle service brakes.
2. Turn the dash mounted railgear air brake control valve to the "On" position. **Do not turn the control valve "On" while the vehicle service brakes are applied.**
3. Apply the vehicle service brakes and release the vehicle parking brakes.
4. Proceed with rail travel. The railgear air brakes will function with the vehicle air brakes when the vehicle brake pedal is pressed.
5. If rail wheels skid or if more braking force is desired, refer to the Railgear Air Brake Pressure Reduction Valve Adjustment procedure.

SERVICE OF AIR BRAKE KIT

The air brake kit must be serviced regularly to avoid damage to the equipment. Table 1 below provides the Recommended Service Schedule and the detailed service procedures follow.

Do not torque the ½" fasteners which pass through the brake linkage. These fasteners must remain slightly loose to allow the air brakes to function freely.

Table 2 provides all other Standard Fastener Torque Values.

Table 1: Recommended Service Schedule

Service Required	Initial 100 km (62 Miles) of road and/or rail use	Daily	Weekly	Monthly
Inspect air brake kit fasteners (re-torque if required)		✓	✓	✓
Check air brake kit for air leaks (repair if required)		✓	✓	✓
Check / adjust brake shoe to rail wheel clearance (see procedure)				✓
Check brake shoe wear (see procedure)				✓

Table 2: Standard Fastener Torque Values

Fastener Size	Fastener Torque Value (ft-lbs) Dry
1" UNC Gr. 8 Fasteners	250
¾" UNC Gr. 8 Fasteners	175
⅝" UNC Gr. 8 Fasteners	150
½" UNC Gr. 8 Fasteners	100
⅜" UNC Gr. 8 Fasteners	40
¼" UNC Gr. 8 Fasteners	12

BRAKE SHOE TO RAIL WHEEL CLEARANCE ADJUSTMENT

The clearance between the brake shoe and the rail wheel must be correctly adjusted to prevent brake drag and to ensure proper braking ability. Check and adjust the brake shoe to rail wheel clearance as follows:

1. With the air brake control valve turned "Off" and the railgear air brakes in the retracted position, visually inspect the railgear air brake components for excessive damage and/or wear and measure the brake shoe to rail wheel clearance.

Acceptable Brake Shoe To Rail Wheel Clearance

$\frac{1}{8}$ " - $\frac{1}{4}$ "

2. If the brake shoe to rail wheel clearance is not within specifications, adjust as follows:
 - a) Loosen the jam nut above the yoke on the air brake actuator rod.
 - b) Disconnect the yoke from the brake linkage by removing the bolt.
 - c) Turn the yoke on the air brake actuator rod up to increase the clearance or down to decrease the clearance. Note that due to the leverage ratio on the brake linkage, the yoke must be moved up or down twice the desired distance of the brake shoe.
 - d) When moving the yoke down on the brake actuator rod, do not move the yoke down beyond the point at which the inside bottom face of the yoke is flush with the end of the actuator rod. This is the wear limit of the brake shoe. Replace the brake shoe and re-adjust.
 - e) Re-install the yoke onto the linkage. Do not torque the $\frac{1}{2}$ " fasteners which pass through the brake linkage. These fasteners must remain slightly loose to allow the air brakes to function freely.
 - f) Tighten the jam nut above the yoke on the air brake actuator rod.
3. Re-check the brake shoe to rail wheel clearance and re-adjust as necessary.

RAILGEAR AIR BRAKE PRESSURE REDUCTION VALVE ADJUSTMENT

The pressure reduction valve limits the amount of control air sent to the railgear air brakes and therefore limits the amount of brake force. The pressure reduction valve is supplied set at approximately 50 PSI and can be increased or decreased by up to 50 % (+/-25 PSI) by adjusting the pressure reduction valve setting as follows:

1. Loosen the locknut under the pressure reduction valve cap by turning it counter- clockwise.
2. Turn the pressure reduction valve cap clockwise to increase the braking force or counter-clockwise to decrease the braking force.
3. Turn the locknut clockwise to tighten the locknut against the cap.
4. Test the air brakes and readjust if necessary.

PARTS OF AIR BRAKE KIT

LEGEND:

C = CONTROL
 S = SUPPLY
 D = DELIVERY
 E = EXHAUST

NOTES:

- ITEM 1 TO BE MOUNTED IN CAB WITH ITEM 4.
- INSTALLER TO SUPPLY ANY NECESSARY HOSES AND FITTINGS
- USE ONLY DOT-APPROVED AIR BRAKE HOSE AND FITTINGS.

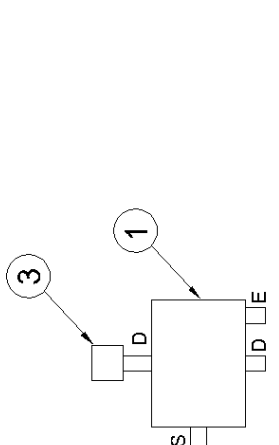

'T' INTO VEHICLE FRONT BRAKE QUICK RELEASE VALVE SUPPLY LINE

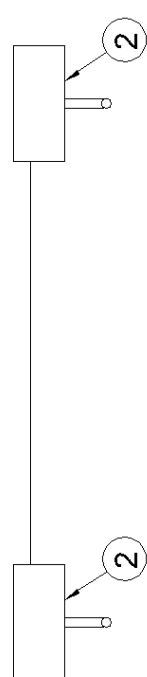

<i>BILL OF MATERIALS</i>			
ITEM	PART NO.	DESCRIPTION OF ITEM (PART)	QUANTITY
1	S-006001	CONTROL VALVE	1
2	R-8560	BRAKE ACTUATOR	2
3	245T-02	1/8" NPT PLUG	1
4	S-006006	ON/OFF PLATE (NOT SHOWN)	1

RAFNA INDUSTRIES LIMITED MONTREAL, QUE.	
NOTE: NOT FULL SCALE ON PAPER	
DESCRIPTION: AIR BRAKE PNEUMATIC LAYOUT FRONT OR REAR RAILGEAR	
DRAWN: AML	DATE: 5/21/12
DIM: INCHES	APPROVED:
DWG NO: K-BB5XXX001A	DRAWING SCALE 1:1
PAGE 1 OF 1	

