

INSTALLATION OF HYDRAULIC KIT
ALL R-890 RAILGEAR UNITS - VF, VFBC, VR (SLEWING)
(Applicable to all R-890 Units Built after 07/01/06)

INSTALLATION SAFETY PRECAUTIONS

If any installation problems are encountered, please call G&B Specialties for technical assistance before continuing with the installation process.



- Failure to heed to any of the following warnings could result in severe bodily injury and/or equipment damage.
- Read and understand this manual completely before attempting installation of the equipment.
- Installation instructions provided below only address the G&B Specialties railgear equipment. Applicable railway company procedures and policies must be adhered to.
- Before performing any work under the vehicle or railgear, ensure the engine is turned off and the parking brake is set.
- Beware of all pinch points on the railgear and keep all parts of the body clear.
- When routing hydraulic hoses, ensure that the hoses do not contact any sharp edges or hot surfaces.
- The railgear's hydraulic system should be on a separate circuit dedicated to the railgear.
- A relief valve should be installed on the railgear hydraulic circuit.
- For vehicles operating more than just the railgear from the PTO pump, a main relief valve should be installed just after the PTO pump to protect the PTO pump.

INSTALLATION OF HYDRAULIC KIT

The following procedure details the installation of the hydraulic kit. The hardware required for this installation is listed in table 1.

Table 1: Hydraulic Kit Installation Parts

Part Number	Description	Qty
R-2407	Operating Valve Bracket	3
R-559-11	Operating Valve Handle (Pre-Installed on Valve)	3
S-802020	Operating Valve	3
HY-849FSO-06-06	Hydraulic Adapter (Pre-Installed on Valve)	4
HY-871FS-06	Hydraulic Adapter (Pre-Installed on Valve)	2
HY-830FS-06	Hydraulic Adapter (Pre-Installed on Valve)	2
S-001033	Operating Decal - For Front Railgear	1
S-001034	Operating Decal - For Rear Railgear	1
-	¼" UNC Gr. 8 Bolt x 2.25" Long	9
-	¼" SAE Washer	18
-	¼" UNC Gr. 3 Nylock Nut	9
Not Supplied	Hydraulic Hoses, Couplers and Fittings	As Req'd

1. The vehicle's PTO pump should be selected to supply 3-5 gallons per minutes (GPM) of oil at 2500 PSI at the front and rear railgear operating valves. A main relief valve should be installed just after the PTO pump to protect it. For vehicles operating more than just the railgear from the PTO pump, the railgear's hydraulic system should be on a separate circuit dedicated to the railgear. A relief valve should be installed on the railgear hydraulic circuit.
2. Install the operating valves:
 - a) Choose a suitable location on the vehicle to mount the three railgear operating valves using the supplied weld-on operating valve brackets. Ensure that there will be sufficient room for the operator to stand safely out of the way of moving parts. Two of the operating valves are equipped with hydraulic fittings; one operating valve equipped with the fittings should be installed near the front railgear and the other operating valve equipped with the fittings should be installed near the rear railgear, both within reach of their respective railgear vertical lock system handles. The third operating valve with no fittings should be installed near the rear railgear within reach of the slewing lock system push-pull cable handle and the other rear operating valve. Weld the operating valve brackets in place.
 - b) Fasten the operating valves to the operating valve brackets using the supplied ¼" fasteners. Torque to 12 ft-lbs dry. Do not over-torque.

3. Install the front and rear railgear vertical motion hydraulics:
 - a) For the vertical motion hydraulics, the operating valve work ports are fitted with a 'T' fitting and a 90° fitting. The check valves located on the railgear have a 'D1' port with a 'T' fitting and a 'D2' port with a straight fitting. Note that caps on the operating valve 'T' fittings and the check valve 'T' fittings are to accommodate the vehicle hydraulic axle lock-up if equipped.
 - b) Fabricate, terminate and connect an appropriate hydraulic hose to reach from the 'T' fitting of the operating valves to the straight fitting in the 'D2' ports on their respective check valves.
 - c) Fabricate, terminate and connect an appropriate hydraulic hose to reach from the 90° fitting on the operating valves to the 'T' fitting in the 'D1' ports of their respective check valves.
 - d) Install appropriate fittings in the 'P' (pressure) and 'T' (tank) ports of the operating valves.
 - e) Fabricate, terminate and connect an appropriate hydraulic hose to reach from the railgear hydraulic system pressure line to the front railgear operating valve 'P' port.
 - f) Fabricate, terminate and connect an appropriate hydraulic hose to reach from the front railgear operating valve 'T' port to the rear railgear operating valve 'P' port.
4. Install the rear railgear slewing (side-to-side) motion hydraulics:
 - a) For the slewing motion hydraulics, the operating valve work ports are not fitted with any fittings. The check valve located on the railgear has a 'D1' port and a 'D2' port, both equipped with straight fittings.
 - b) Install appropriate fittings in the operating valve work ports, 'P' (pressure) port, and 'T' (tank) port.
 - c) Fabricate, terminate and connect an appropriate hydraulic hose to reach from the operating valve upper work port (closest to the operating valve handle) to the check valve 'D2' port.
 - d) Fabricate, terminate and connect an appropriate hydraulic hose to reach from the operating valve lower work port to the check valve 'D1' port.
 - e) Fabricate, terminate and connect an appropriate hydraulic hose to reach from the rear railgear vertical motion operating valve 'T' (tank) port to the rear railgear slewing motion operating valve 'P' (pressure) port.

- f) Fabricate, terminate and connect an appropriate hydraulic hose to reach from the rear railgear slewing motion operating valve 'T' port to the vehicle's hydraulic return line.
5. Ensure that none of the hoses contact any sharp edges or hot surfaces. Secure these hoses in place with tie-wraps. Ensure that there is enough slack in the hoses for the railgear to function. Where necessary, fasten the hoses to the frame with installer-supplied 'P' hose clips and hardware.
6. Affix the supplied front and rear railgear operation decals in suitable locations adjacent to their respective operating valves.
7. Adjust the operating valve relief valve pressure as per the procedure in the Hydraulic Kit Operation, Service and Parts manual.
8. Test the operation of the controls. Refer to the operation procedure in the Railgear Kit and Hydraulic Kit Operation, Service and Parts manuals.

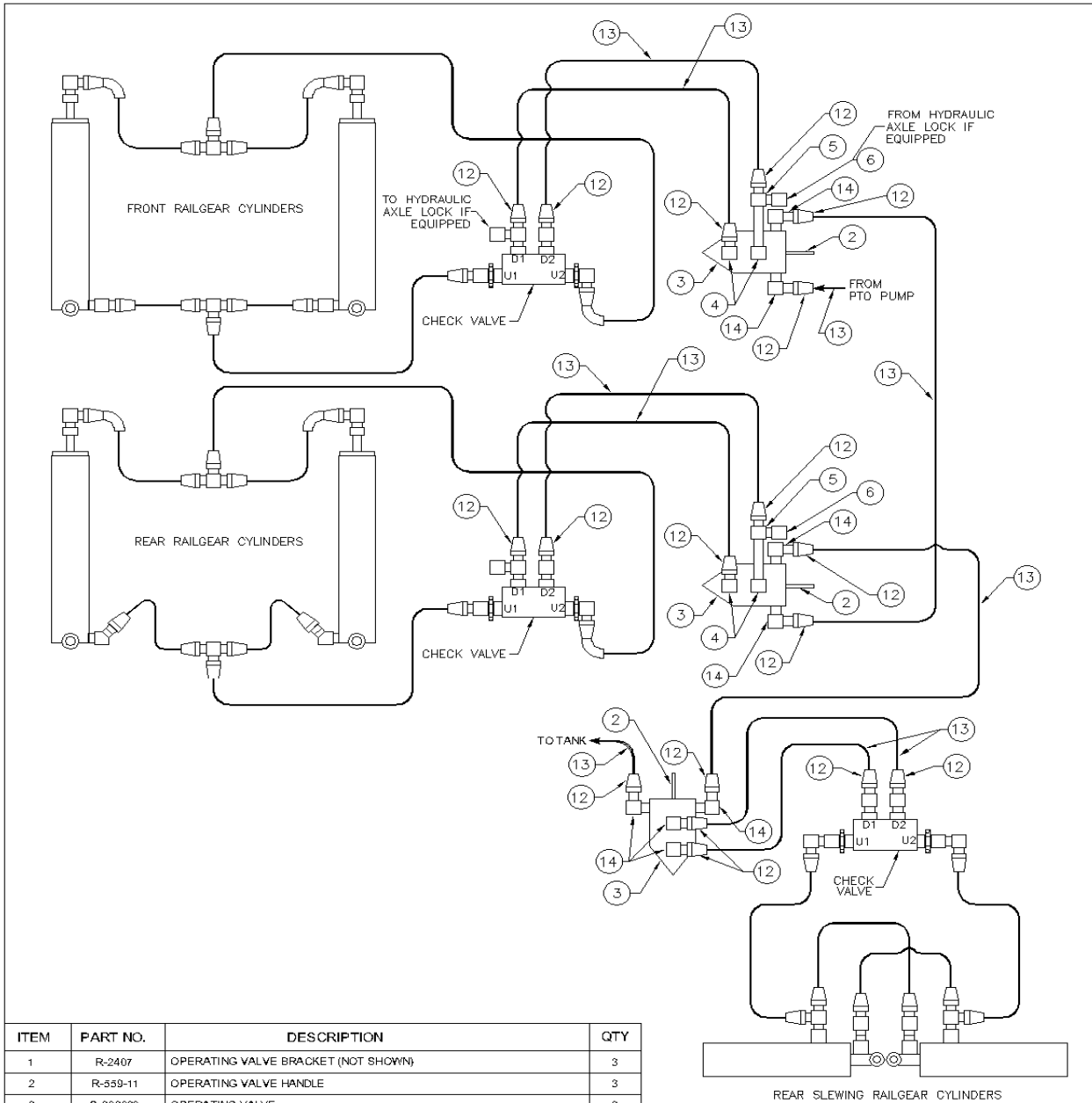

ITEM	PART NO.	DESCRIPTION	QTY
1	R-2407	OPERATING VALVE BRACKET (NOT SHOWN)	3
2	R-559-11	OPERATING VALVE HANDLE	3
3	S-802020	OPERATING VALVE	3
4	HY-849FSO-06	HYDRAULIC FITTING	4
5	HY-871FS-06	HYDRAULIC FITTING	2
6	HY-830FS-06	HYDRAULIC FITTING	2
7	S-001033	OPERATING DECAL (NOT SHOWN)	1
8	S-001034	OPERATING DECAL (NOT SHOWN)	1
9	-	1/4" UNC GR. 8 BOLT X 2.25" LONG (NOT SHOWN)	9
10	-	1/4" SAE WASHER (NOT SHOWN)	18
11	-	1/4" UNC GR. 3 NY LOCK NUT (NOT SHOWN)	9
12	-	HYDRAULIC COUPLER TO FIT (SUPPLIED BY INSTALLER)	N/A
13	-	HYDRAULIC HOSE TO FIT (SUPPLIED BY INSTALLER)	N/A
14	-	HYDRAULIC FITTING TO FIT (SUPPLIED BY INSTALLER)	N/A

REV	CHANGE	DATE	BY	APR
A	DRAWING RELEASED	6/20/06	AML	

G & B SPECIALTIES INC.
DESIGN - ENGINEERING - MANUFACTURING

DESCRIPTION:
R-890 HYDRAULIC KIT W/ SLEWING REAR

REFERENCE:
ALL R-890 UNITS BUILT AFTER 7/01/06

P/N: K-H89XTX002 DATE: JUN/20/04

DRAWN: AML APPR:

DIM: INCHES SCALE: N/A

SHEET: 1 OF 1 DWG#: K-H89XTX002

OPERATION, SERVICE AND PARTS OF HYDRAULIC KIT

(Applicable to all R-890 Units Built after 07/01/06)

SAFETY PRECAUTIONS

If any operating, service or parts problems are encountered, please call G&B Specialties for technical assistance.



- Failure to heed to any of the following warnings could result in severe bodily injury and/or equipment damage.
- Read and understand this manual completely before attempting operation of the railgear-equipped vehicle.
- Operating instructions provided below only address the Rafna Industries railgear equipment. Applicable railway company procedures and policies must be adhered to.
- Railway company rules governing rail travel must be observed at all times.
- Before performing any work under the vehicle or railgear, ensure the engine is turned off and the parking brake is set.
- Ensure all body parts and loose clothing are clear of any moving parts of the railgear. Be aware of all pinch points.
- Never operate the vehicle if the Gross Vehicle Weight Rating (GVWR), Gross Axle Weight Rating Front or Rear (GAWR), or the wheel or tire load ratings are exceeded.

OPERATION OF HYDRAULIC KIT

With the hydraulic kit installed on this vehicle, it may be operated as normal.

Never operate the vehicle if the Gross Vehicle Weight Rating (GVWR), Gross Axle Weight Rating Front or Rear (GAWR), or the wheel or tire load ratings are exceeded.

Refer to the Railgear Kit Operation, Service and Parts manual for information on the mechanical operation, service and parts of the railgear.

Location And Operation Of The Railgear Hydraulic System Controls:

1. The PTO must be engaged following the manufacturer's instructions. The railgear should not move until the operating valve is actuated.
2. The front railgear is equipped with an operating valve to control the vertical motion of the railgear. The rear railgear is equipped with two operating valves; one for the railgear's vertical motion and one for the slewing (side-to-side) motion. The direction of motion of the railgear is selected by actuating the appropriate operating valve; the railgear should only move in the selected direction.
3. To stop the movement of the railgear, bring the handle on the respective railgear operating valve to the center position.
4. Disengage the PTO following the manufacturer's instructions.

SERVICE OF HYDRAULIC KIT

The hydraulic kit must be serviced regularly to avoid damage to the equipment. Table 1 provides the Recommended Service Schedule and table 2 provides Standard Fastener Torque Values.

The recommended oil for the railgear hydraulic system is **DEXRON III** or equivalent. In extremely cold weather areas/seasons, Tellus S4 VX32 or equivalent may be used.

Table 1: Recommended Service Schedule

Service Required	Initial 100 km (62 Miles) of road and/or rail use	Daily	Weekly	Monthly
Inspect hydraulic kit fasteners (re-torque if required)		✓	✓	✓
Inspect all hydraulic fittings and hoses for leaks and wear.		✓	✓	✓

Table 2: Standard Fastener Torque Values

Fastener Size	Fastener Torque Value (ft-lbs) Dry
1" UNC Gr. 8 Fasteners	250
¾" UNC Gr. 8 Fasteners	175
⅝" UNC Gr. 8 Fasteners	150
½" UNC Gr. 8 Fasteners	100
⅜" UNC Gr. 8 Fasteners	40
¼" UNC Gr. 8 Fasteners	12

HYDRAULIC SYSTEM RELIEF VALVE SETTING

The following procedure details how to adjust the railgear pressure relief valve settings. One relief valve is located on each operating valve and there may be one or more additional relief valves in the railgear hydraulic system. An adjustment of the relief valve settings should be carried out at installation and/or if ever there appears to be inadequate hydraulic pressure to operate the railgear.

1. Locate the hydraulic hose that connects the front railgear operating valve to the railgear hydraulic system pressure line. Release the pressure in the railgear hydraulic system and disconnect this hose from the front railgear operating valve.
2. Install a combination test gauge (up to 3000 PSI) and shutoff valve between the disconnected hydraulic hose and the front operating valve. The pressure gauge will indicate the relief valve setting, while the shutoff valve will enable a false load to be put on the hydraulic pump. Ensure that the shutoff valve is installed between the test gauge and front operating valve.
3. Engage the hydraulic pump.
4. Close the shutoff valve to enable the railgear hydraulic system relief valve to start releasing pressure. The pressure reading on the test gauge should indicate 2000 PSI. If this reading is incorrect, adjust the railgear hydraulic system relief valve accordingly.
5. Once the correct pressure on the railgear hydraulic system relief valve is obtained, open the shutoff valve.
6. Proceed to adjust each operating valve relief valve setting as follows:
 - a) Have an assistant watch the test gauge pressure reading while adjusting the relief valve settings.
 - b) Ensure the shutoff valve has been completely opened.
 - c) With the railgear fully raised in road position, select "UP" on the operating valve OR with the railgear fully slewed to one side, select that same direction on the operating valve. Hold in this position until the hydraulic oil passes over the relief valve and a reading is taken on the test gauge.
 - d) The pressure should be 1800 PSI on all operating valves. Adjust the relief valve setting accordingly.
 - e) Proceed to adjust the second and third operating valve relief valve setting.
7. Release the pressure in the railgear hydraulic system and remove the test gauge and shutoff valve.
8. Reconnect and tighten all hydraulic hoses.

PARTS OF HYDRAULIC KIT

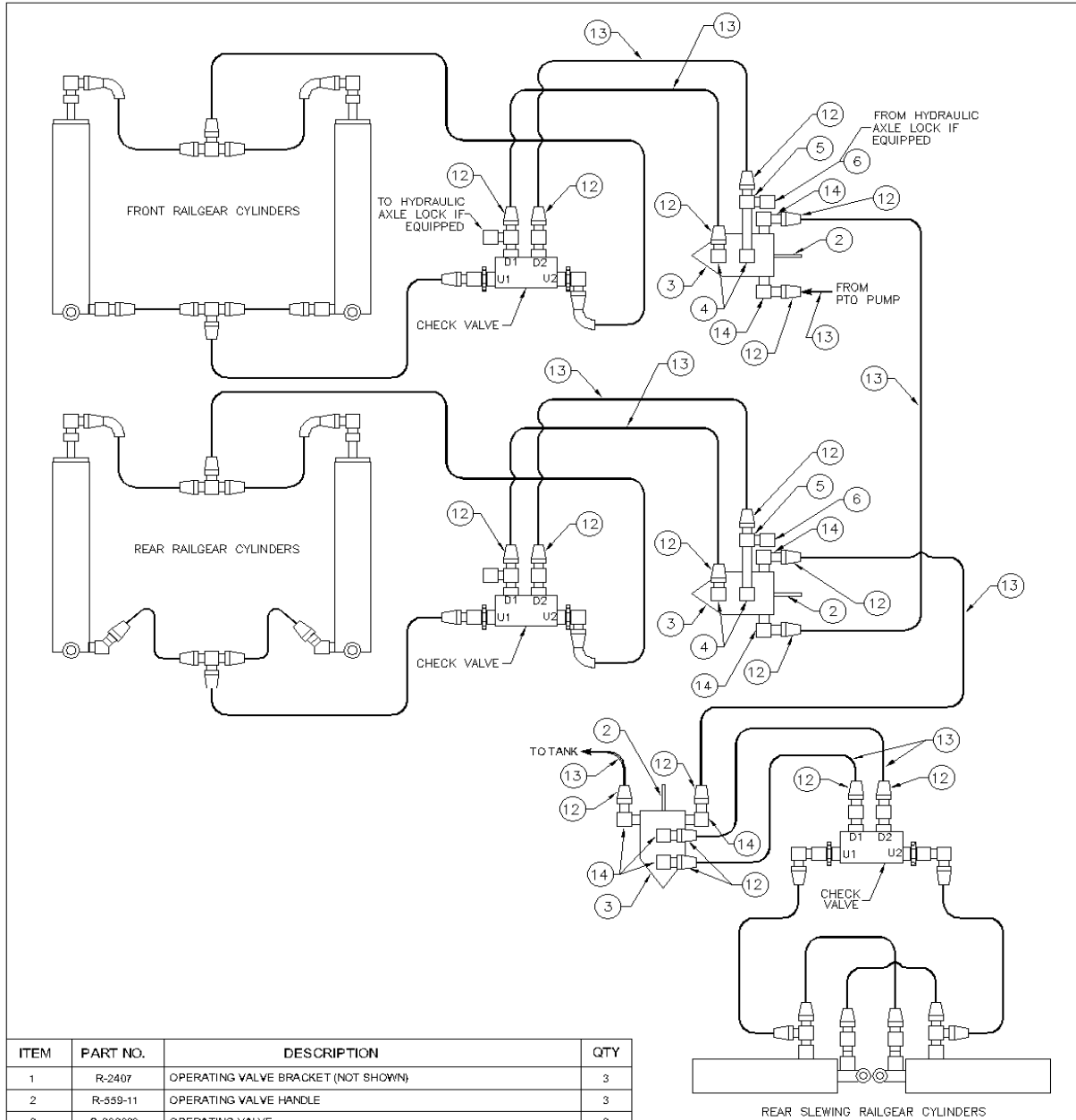

ITEM	PART NO.	DESCRIPTION	QTY
1	R-2407	OPERATING VALVE BRACKET (NOT SHOWN)	3
2	R-559-11	OPERATING VALVE HANDLE	3
3	S-802020	OPERATING VALVE	3
4	HY-849FSO-06	HYDRAULIC FITTING	4
5	HY-871FS-06	HYDRAULIC FITTING	2
6	HY-830FS-06	HYDRAULIC FITTING	2
7	S-001033	OPERATING DECAL (NOT SHOWN)	1
8	S-001034	OPERATING DECAL (NOT SHOWN)	1
9	-	1/4" UNC GR. 8 BOLT X 2.25" LONG (NOT SHOWN)	9
10	-	1/4" SAE WASHER (NOT SHOWN)	18
11	-	1/4" UNC GR. 3 NY LOCK NUT (NOT SHOWN)	9
12	-	HYDRAULIC COUPLER TO FIT (SUPPLIED BY INSTALLER)	N/A
13	-	HYDRAULIC HOSE TO FIT (SUPPLIED BY INSTALLER)	N/A
14	-	HYDRAULIC FITTING TO FIT (SUPPLIED BY INSTALLER)	N/A

A	DRAWING RELEASED	6/20/06	AML
REV	CHANGE	DATE	BY
 G & B SPECIALTIES INC. <small>1100 W. HICKORY AVE. SUITE 100, BERWICK, PA 17604-1000 800-541-6988 FAX 717-532-0200 WWW.GBSP.COM</small>			
DESIGN • ENGINEERING • MANUFACTURING			
DESCRIPTION: R-890 HYDRAULIC KIT W/ SLEWING REAR			
REFERENCE: ALL R-890 UNITS BUILT AFTER 7/01/06			
P/N: K-H89XTX002		DATE: JUN/20/04	
DRAWN: AML		APPR:	
DIM: INCHES		SCALE: N/A	
SHEET: 1 OF 1		DWG#: K-H89XTX002	