

TECHNICAL SERVICE BULLETIN
RAFNA RAILGEAR

ISSUE DATE: July 2, 2007

TSB NUMBER: TSB172

HAZARD / URGENCY RATING

| | |
|---|--|
| X | DANGER - Physical harm is possible if TSB is not observed or followed |
| X | WARNING - Equipment damage is possible if TSB is not observed or followed |
| X | CAUTION - Essential issue affecting operation, service, parts or installation |
| X | INFORMATIONAL - Advisory which may be of interest |

APPLICABLE EQUIPMENT:

G&B Specialties R-290 Railgear Front Bumper Extensions for 2008 Ford F-Series
(F250, F350, F450, F550)

SUMMARY:

Use **Loctite Red** when installing fasteners for front frame extensions.
(See loctite notes on references drawings TSB172-1 and TSB172-2)
For reference only

IMPACT:

Eliminates fasteners from coming loose.

ACTION:

Apply **Loctite Red** on fasteners during assembly as shown on reference drawings TSB172-1 and TSB172-2.
For reference only

**TECHNICAL SERVICE BULLETIN
RAFNA RAILGEAR**

ISSUE DATE: July 2, 2007

TSB NUMBER: TSB172

HAZARD / URGENCY RATING

| | |
|---|--|
| X | DANGER - Physical harm is possible if TSB is not observed or followed |
| X | WARNING - Equipment damage is possible if TSB is not observed or followed |
| X | CAUTION - Essential issue affecting operation, service, parts or installation |
| X | INFORMATIONAL - Advisory which may be of interest |

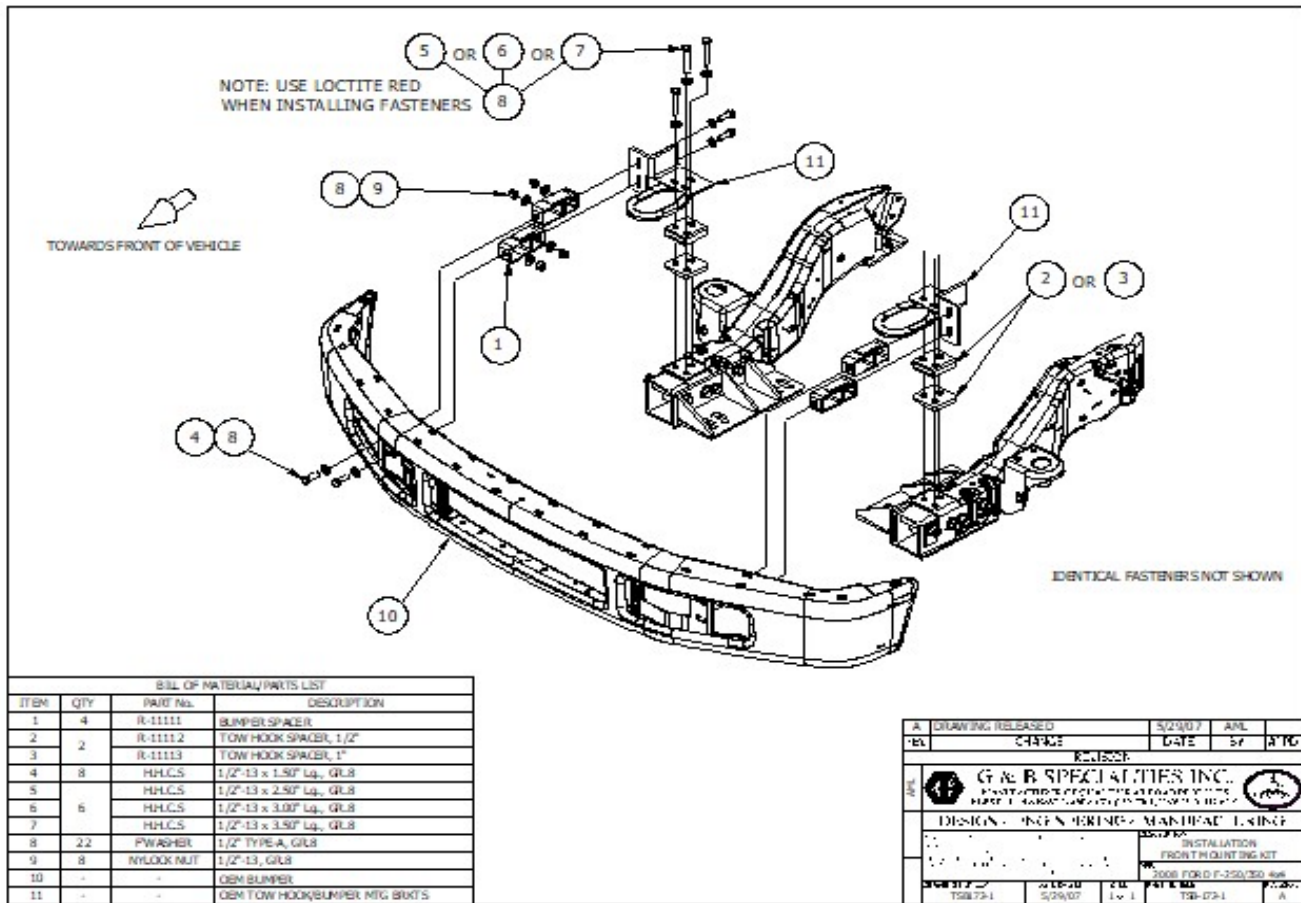

**TECHNICAL SERVICE BULLETIN
RAFNA RAILGEAR**

ISSUE DATE: July 2, 2007

TSB NUMBER: TSB172

HAZARD / URGENCY RATING

| | |
|---|--|
| X | DANGER - Physical harm is possible if TSB is not observed or followed |
| X | WARNING - Equipment damage is possible if TSB is not observed or followed |
| X | CAUTION - Essential issue affecting operation, service, parts or installation |
| X | INFORMATIONAL - Advisory which may be of interest |

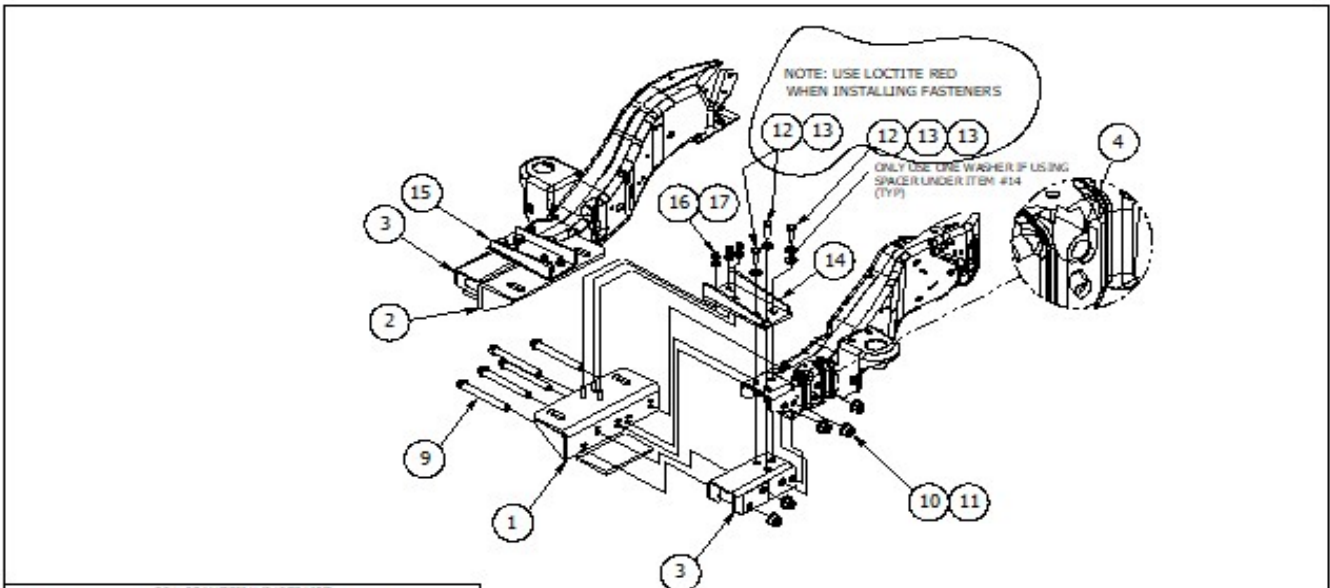

| BILL OF MATERIAL/PARTS LIST | | | |
|-----------------------------|-----|-------------|--------------------------------------|
| ITEM | QTY | PART No. | DESCRIPTION |
| 1 | 1 | R-111 200-A | MOUNTING BRACKET, DRIVERS SIDE |
| 2 | 1 | R-11 120P-A | MOUNTING BRACKET, PASSENGERS SIDE |
| 3 | 2 | R-1200-A | FRAME EXTENSION |
| 4 | 2 | R-11100 | FRAME SPACER |
| 5 | 2 | R-2631 | RAILGEAR MOUNTING SHIM, 2" |
| 6 | 2 | R-2060 | RAILGEAR MOUNTING SHIM, 1/2" |
| 7 | 2 | R-11127 | RAILGEAR MOUNTING SHIM, 1/8" |
| 8 | 2 | R-11128 | RAILGEAR MOUNTING SHIM, 1/4" |
| 9 | 10 | H.H.C.S | 5/8"-11 x 6.00" Lg., GRLB |
| 10 | 20 | P.WASHER | 5/8" TYPE-A, GRLB |
| 11 | 10 | NYLOCK NUT | 5/8"-11, GRLB |
| 12 | 6 | H.H.C.S | 1/2"-13 x 2.00" Lg., GRLB |
| 13 | 8 | P.WASHER | 1/2" TYPE-A, GRLB |
| 14 | 1 | R-11 120D | UPPER SUPPORT BRKT., DRIVERS SIDE |
| 15 | 1 | R-11 120P | UPPER SUPPORT BRKT., PASSENGERS SIDE |
| 16 | 8 | P.WASHER | 3/8" TYPE-A, GRLB |
| 17 | 6 | NYLOCK NUT | 3/8"-11, GRLB |

| | | | | |
|--------|--|---------------|---|-------|
| A | DRAWING RELEASED | 4/23/07 | AML | |
| REV | 7447 F | EXT | 30 | 2/0 |
| REV |  G & B SPECIALTIES INC. 535 WEST 3 RD STREET, BERWICK, PA 17004 (717) 752-5901 FAX (717) 752-6397 | | | |
| DESIGN | ENGINEERING | MANUFACTURING | INSTALLATION FRONT MOUNT BRACKET 2008 ROTO P 250/350 4x2 | |
| REV | DATE | BY | CHKD | APP'D |
| 58172 | 4/23/06 | J.V.1 | TSB-D2-2 | A |