

**TECHNICAL SERVICE BULLETIN
RAFNA RAILGEAR**

ISSUE DATE: 6/23/14

TSB NUMBER: TSB-192

HAZARD / URGENCY RATING

X	DANGER - Physical harm is possible if TSB is not observed or followed
X	WARNING - Equipment damage is possible if TSB is not observed or followed
X	CAUTION - Essential issue affecting operation, service, parts or installation
X	INFORMATIONAL - Advisory which may be of interest

APPLICABLE EQUIPMENT:

R-290

SUMMARY:

When the axle Stover nut is used too many times, it loses the ability to maintain the proper torque. If the Stover nut is used too many times it is prone to loosening and falling off. For this reason, a onetime application is being required. Due to size variance of the grommets on the bellows it is necessary to compress to dimensions shown in order to maintain a consistent distance across the head of the axle bolt and the axle Stover nut. After the grommet has been compressed an additional washer has to be added to also maintain a consistent distance.

IMPACT:

Failure to replace the nuts and bolts can cause the nut to fall off and the axle bolt to fall out of the axle. Failure to maintain the proper assembly distance between the axle Stover nut and the head of the bolt can cause either too much or too little movement in the axle bushings.

ACTION:

New OEM fastener kit (R-990KIT-345) must be used when changing out axles and or doing any kind of repair work where bolts and nuts are removed. This fastener kit will be included when new replacement axles are ordered. Axle Stover nut and bolt will be a one use only application. When new nuts and bolts are replaced use red high strength lock tight. The grommets on the bellows will have to be compressed within tolerances listed on drawing number R2930RW ASSY (see sheet below). An additional washer is to be added between the bushing and the compressed bellows as shown below.

R:\RAFNA NEW\DRAWINGS\R2900\IR-2930RW ASSY.dwg

BILL OF MATERIAL PARTS LIST

ITEM	QTY	PART NUMBER	DESCRIPTION
1	1	R-2930RW	AXLE TUBE
2	8	Washer	3/4" TYPE-A, GR8
3	2	R-29041	Slotted Bushing/Bushing
4	2	R-29041A	Bushing (NOT SHOWN)
5	2	R-29042	Pin
6	2	Grease Zerk	1/8 NPT ST. Zerk
7	2	LOCK NUT	5/8" UNC. STOVER
8	2	R-1505	BELLOWS

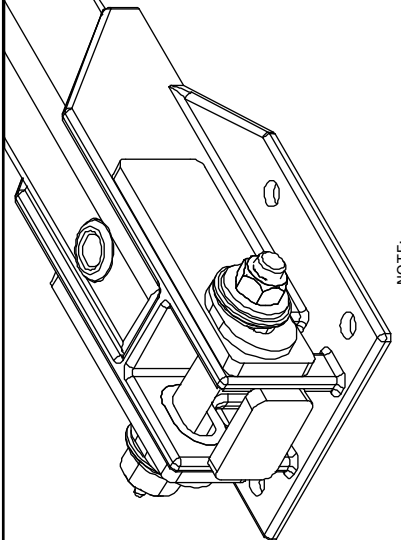

NOTE:

1. GUIDE TUBE, BOOT, UPPER AND LOWER CROSS FRAMES ARE NOT SHOWN FOR CLARITY.
2. NUTS AND BOLTS NEED TO BE REPLACED AFTER EACH USE.
3. USE LOCKTITE 262 (RED) HIGH STRENGTH WITH REPLACED NUTS AND BOLTS.

SPECIAL NOTE:
ON BELLOW P/N R-1505 MUST CHECK GROMMET HAS TO BE BETWEEN .134" - .110" WIDTH. IF NOT PRESS TO GET DESIRED WIDTH.

DETAIL A

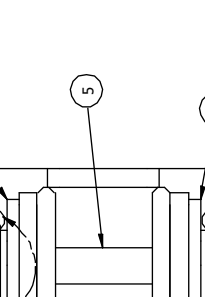

DO NOT SCALE DRAWING

TO DIMENSIONS UNLESS OTHERWISE SPECIFIED	UNIT	TOLERANCE
ANGLES	DEGREES	±.05
BORES	INCHES	±.0005
CHAMFERED ENDS	INCHES	±.0005
DIAMETERS	INCHES	±.0005
LENGTHS	INCHES	±.0005
RADIUSES	INCHES	±.0005
THICKNESSES	INCHES	±.0005
WIDTHS	INCHES	±.0005

ALL WELDS TO CONFORM TO AWS D1.1

* A NEW OEM FASTENER KIT (R-990KIT-354) MUST BE USED WHEN CHANGING OUT AXLES AND OR DOING ANY KIND OF REPAIR WORK WHERE BOLTS AND NUTS ARE REMOVED. * (ie... ONE TIME USE ONLY).

* THIS FASTENER KIT WILL BE INCLUDED WHEN NEW REPLACEMENT AXLES ARE ORDERED. *

R:\RAFNA NEW\DRAWINGS\R2900\IR-2930RW ASSY.dwg

REV	CHANGE	DATE	BY	APPD
E	SPECIAL NOTE CHANGED	12/3/14	KND	JL
D	ADDITIONAL INFORMATION ADDED	7/11/14	KND	JL
C	WASHERS ADDED/SPECIAL NOTE	6/19/14	KND	JL
B	ADDITION OF NOTES 2 & 3	6/17/14	KND	JL
A	DRAWING RELEASED	8/29/2013	JL	JL

G & B SPECIALTIES INC.
DESIGN - ENGINEERING - MANUFACTURING

1200 W. 3RD STREET, BERWICK, PA 17004
TEL: 717-752-5901 FAX: 717-752-6397

DRAWING NUMBER: R2900RW ASSY
DATE DRAWN: 8/29/2013
SHEET: 1 OF 1
REV: R-2930RW ASSY E

