

INSTALLATION OF R-450 VERTICAL FRONT RAILGEAR KIT ALL RAILGEAR UNITS

INSTALLATION SAFETY PRECAUTIONS

If any installation problems are encountered, please call G&B Specialties, Inc. for technical assistance before continuing with the installation process.



- Failure to heed to any of the following warnings could result in severe bodily injury and/or equipment damage.
- Read and understand this manual completely before attempting installation of the equipment.
- Installation instructions provided below only address the RAFNA railgear equipment. Applicable railway company procedures and policies must be adhered to.
- Before performing any work under the vehicle or railgear, ensure that the engine is turned off and the parking brake is set.
- Beware of all pinch points on the railgear and keep all parts of the body clear.
- Always disconnect the vehicle's battery when welding on the vehicle or railgear in order to protect the vehicle's electrical system.
- Ensure all removed components are given to the vehicle owner after the installation of the railgear. These components must be re-installed if the railgear is removed from the vehicle.
- Railway Company rules governing rail travel must be observed at all times.
- Never operate the vehicle if the Gross Vehicle Weight Rating (GVWR), Gross Axle Weight Rating (GAWR), or the wheel or tire load ratings are exceeded.

INSTALLATION OF VERTICAL FRONT RAILGEAR KIT

The following procedure details the installation of the front railgear kit. The hardware required for this installation is listed in the table below.

Table 1: Vertical Front Railgear Kit: K-R45VXXR4531C

Part Number	Description	Qty
R-4531AC	Vertical Front Railgear	1
R-001	10" Wheel Assembly	2
R-1000R	Rail Sweep, Driver's Side	1
R-1000L	Rail Sweep, Passenger's Side	1
R-051	Side Wand Set	1
R-2687AL	Front Bumper	1
R-4699	Front Bumper Support	2
R-4698	Collar	2
S-001031	Railgear Operation Decal	1
R-990KIT-204 Rail Wheel Mounting (2 Kits)	1/2" UNC Gr.8 Bolt x 2 1/4" Long	8
	1/2" Gr.8 Washer	16
	1/2" UNC Gr.8 Nylon Insert Lock Nut	8
R-990KIT-024 Railgear Mounting Hardware	3/4" UNC Gr.8 Bolt x 2 1/2" Long	8
	3/4" Gr.8 Washer	16
	3/4" UNC Gr.8 Nylon Insert Lock Nut	8

1. Ensure that the front mounting kit has been installed on the vehicle prior to installing the railgear kit.
2. In order to install the railgear at the correct height, ensure and that the vehicle is resting on all of its properly inflated tires.
3. Position and support the railgear so that the mid-height mounting holes on the railgear align with the slots in the front mounting plates as shown. Center the railgear on the slots.
4. Fasten the railgear to the front mounting plates using four 3/4" bolts, eight 3/4" washers and four 3/4" nuts as shown. Tighten but do not torque the 3/4" fasteners as they will be torqued after the alignment procedure is completed.
5. Place the rail wheels below the mounting tables on the railgear axle. Place the rail sweeps in front of the rail wheels and on top of the mounting tables. Fasten the rail wheels and rail sweeps to the mounting tables with eight 1/2" x 2 1/4" long bolts, sixteen 1/2" washers and eight 1/2" nuts.
6. Tighten but do not torque the 1/2" fasteners as they will be torqued following the railgear alignment procedure.

Note:

Install the railgear hydraulic system as per the Hydraulic Kit Installation manual before continuing with the following steps.

7. Install the railgear operation decal near to the railgear hydraulic controls where it is clearly visible to the operator.
8. Follow the “Vehicle Front Tire Clearance Adjustment” procedure detailed in the “Operations” section of this manual.
9. Position the collars on the railgear outer tube so that they are tight against the top of the railgear upper cross frame clamps as shown. Weld the collars in place using 1/4” fillet welds on the top surface of the collars.
10. Follow the “Railgear Alignment” procedure detailed in the “Operations” section of this manual.
11. Fasten the hook to the hook supports using one 1/2” x 2 1/2” long bolt, two 1/2” washers and one 1/2” nut. Tighten but do not torque this 1/2” fastener, as the hook must be free to swing.
12. Support the front railgear in the road position. Align the hook supports on the railgear frame so that the hook will engage the latch. Ensure that the hook can swing freely to engage and disengage.
13. Clamp the hook supports in place. Using the slots in the hook supports as templates, drill four 13/32” diameter holes in the railgear frame through the center of the slots. Fasten the hook supports to the railgear frame using four 3/8” x 1 1/4” long bolts, eight 3/8” washers and four 3/8” nuts. Torque the 3/8” fasteners to 40 ft-lbs dry. Do not over torque.
14. Follow the Railgear Lock System Adjustment Procedure detailed in operations section of this manual.
15. Fasten front bumper supports to the bumper provided in this kit using four 1/2” x 2 1/4” long bolts, eight 1/2” washers and four 1/2” nuts as shown. Torque the 1/2” fasteners to 100 ft-lbs dry. Do not over torque.
16. Align the front bumper supports with the front railgear cross channel. Weld the front bumper supports to the railgear cross channel using 1/4” fillet welds, both sides. Ensure that that the bumper does not obstruct the headlights.
17. Fasten the side wands to the front bumper with the supplied fasteners.
18. Follow the Rail Sweep Adjustment procedure detailed in “Operations” section of this manual.
19. Torque all fasteners as detailed in “Operations” section of this manual.
20. Grease the railgear at all lubrication points as detailed in “Operations” section of this manual.
21. Paint any parts that were welded or heated.

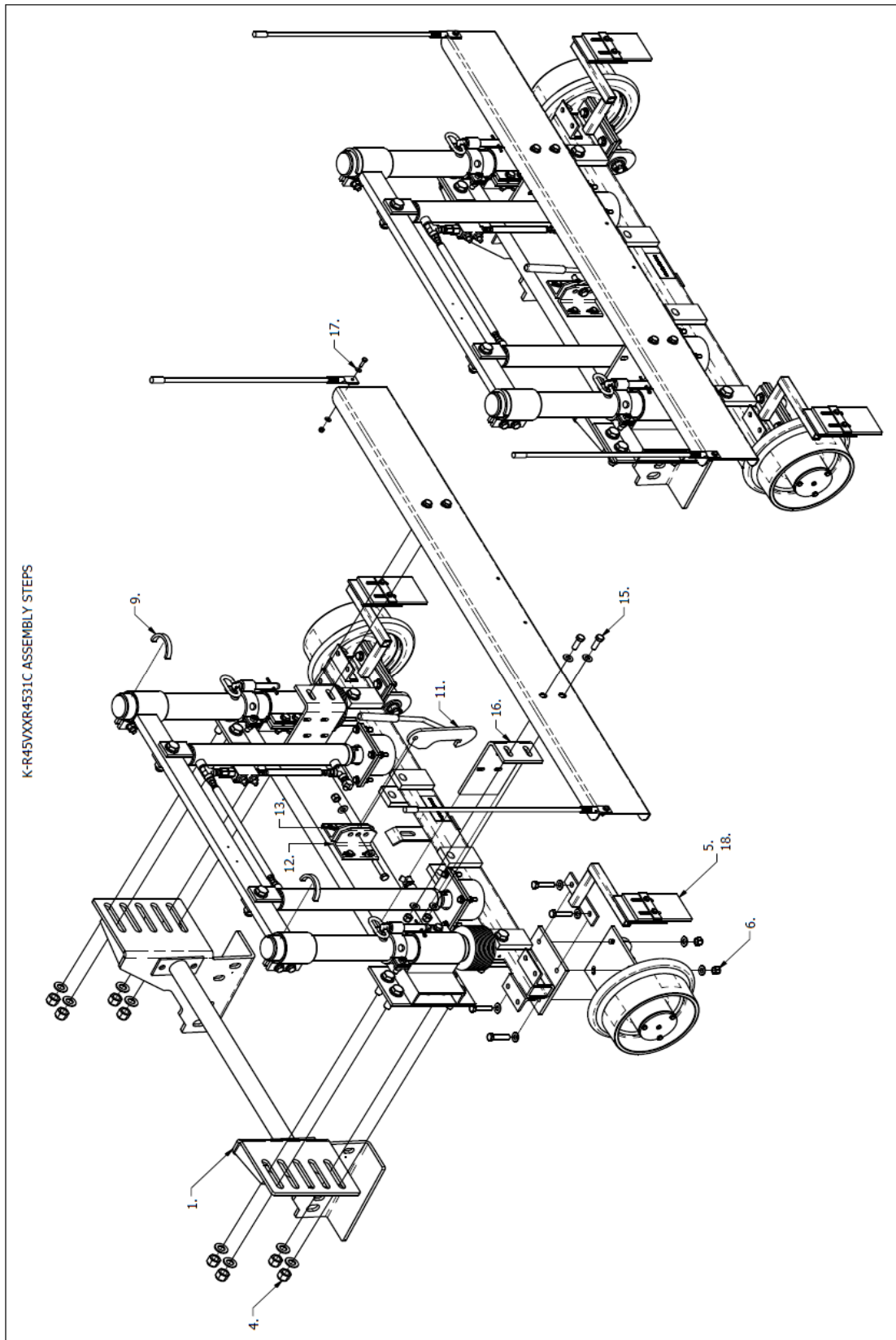

Figure 1

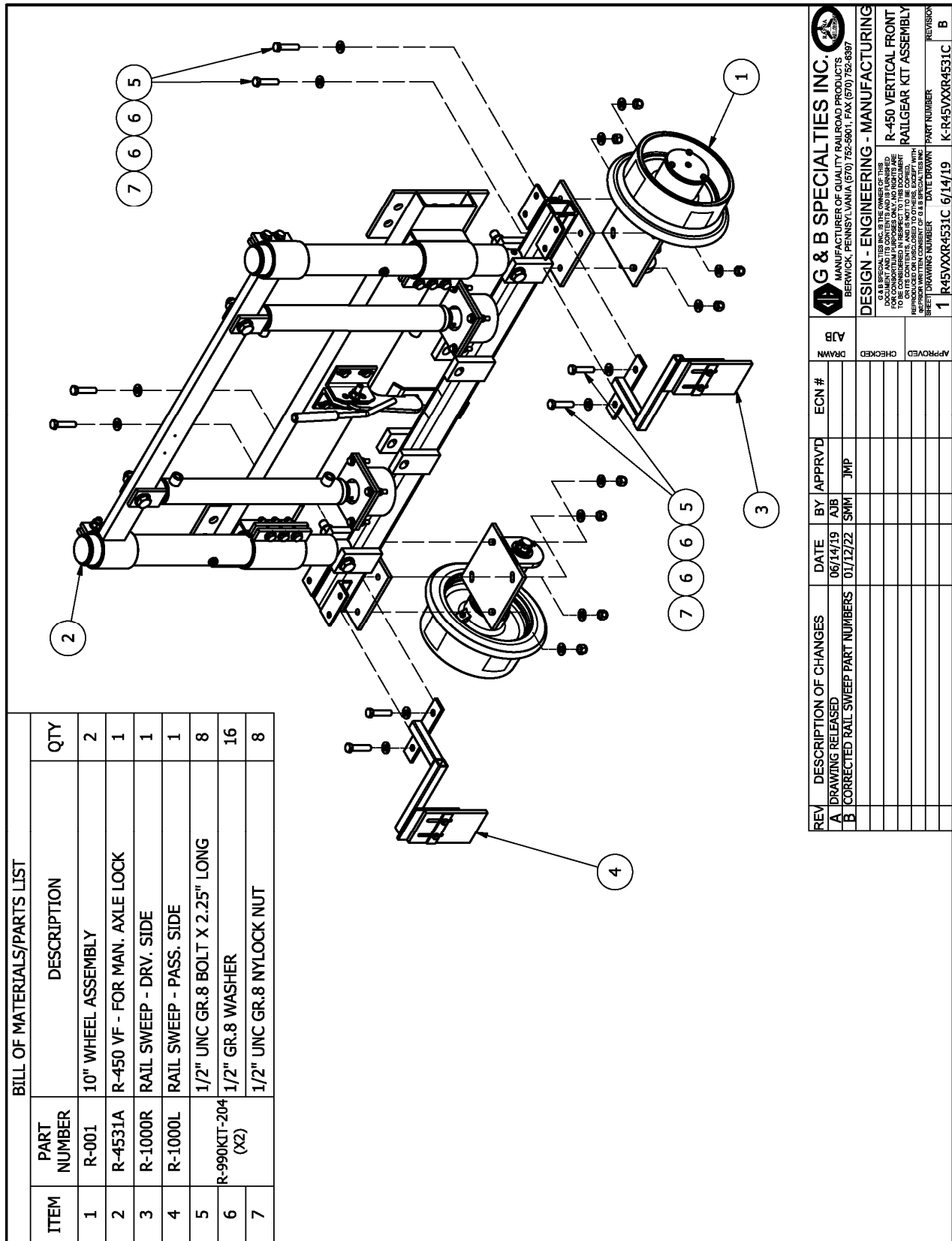

Figure 2

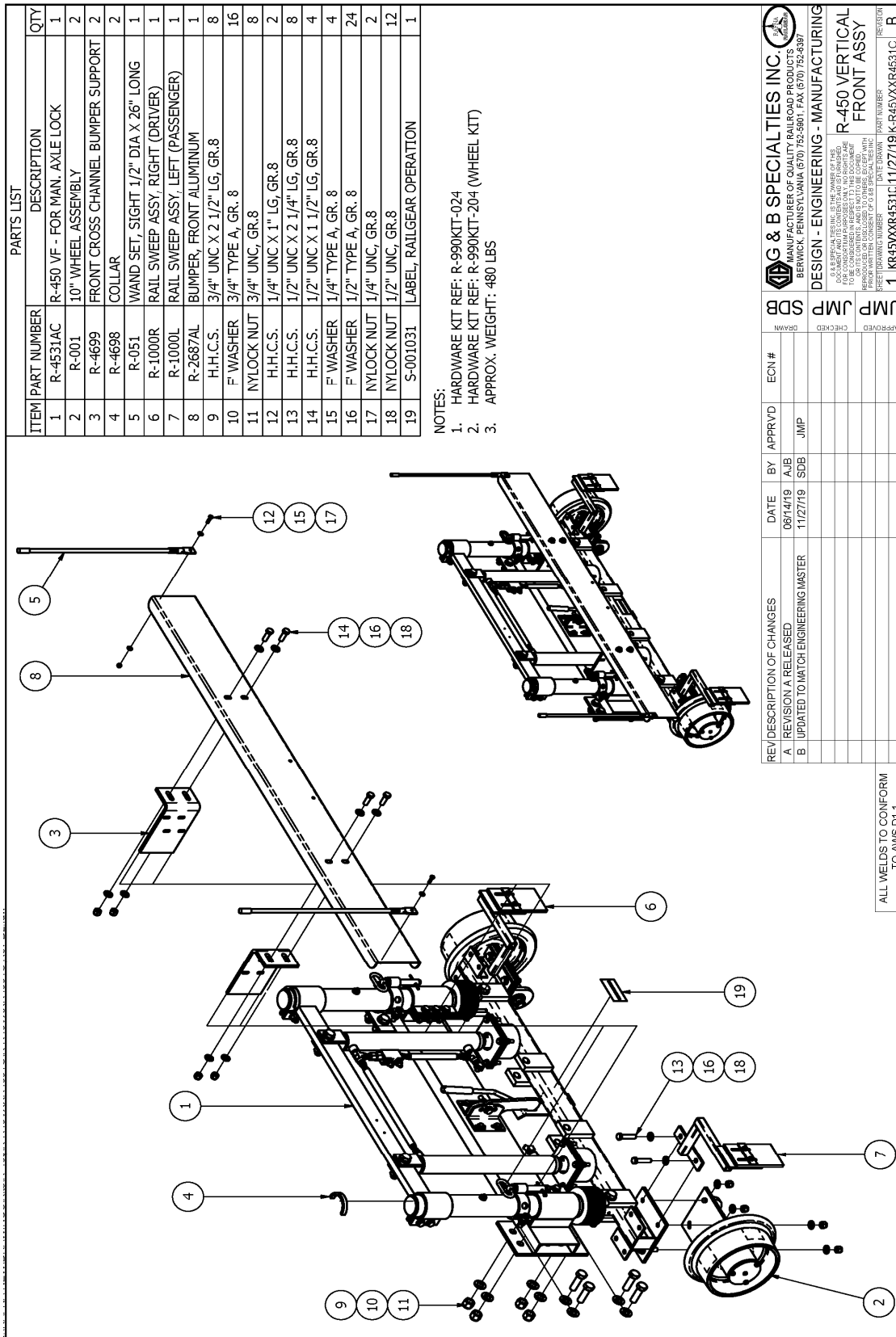
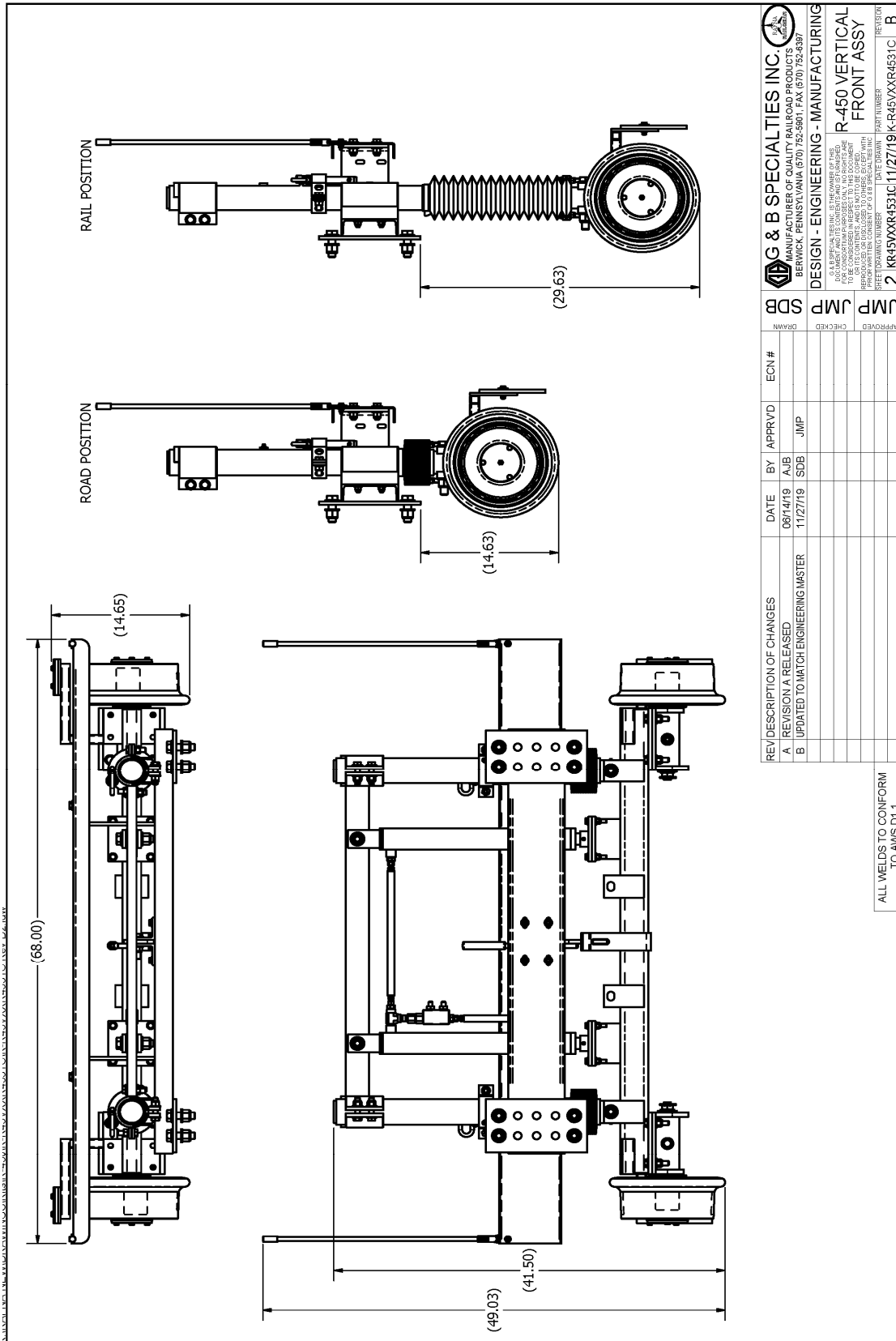

Figure 3



G & B SPECIALTIES INC. MANUFACTURER OF QUALITY RAILROAD PRODUCTS BERWICK, PENNSYLVANIA (717) 752-5901, FAX (717) 752-6397		DESIGN - ENGINEERING - MANUFACTURING <small>FOR THE PURPOSES OF THIS DRAWING, THE COMPANY IS TO BE CONSIDERED AS THE DESIGNER, MANUFACTURER, AND SUPPLIER OF THE PRODUCT. THE COMPANY IS NOT RESPONSIBLE FOR THE DESIGN, MANUFACTURE, OR INSTALLATION OF OTHERS' EQUIPMENT.</small>		STREET ADDRESS: 535 WEST 3RD STREET, BERWICK, PA 17004 PHONE: (717) 752-5901 FAX: (717) 752-6397 PART NUMBER:	
APPROVED JMP	CHECKED JMP	ECN #	DATE 06/14/19	BY A/JB	APPROVD JMP
APPROVED SDB	CHECKED SDB	ECN #	DATE 11/27/19	BY SDB	APPROVD JMP
REVISIONS:					
A. REVISION A RELEASED					
B. UPDATED TO MATCH ENGINEERING MASTER					
ALL WELDS TO CONFORM TO AWS D1.1					
2 KR45VXXR4531C 11/27/19 K-R45VXXR4531C B					

Figure 4

OPERATION OF R-450 VERTICAL FRONT RAILGEAR KIT ALL RAILGEAR UNITS

OPERATION SAFETY PRECAUTIONS

If any operating, services or parts problems are encountered, please call G&B Specialties, Inc. for technical assistance.



- Failure to heed to any of the following warnings could result in severe bodily injury and/or equipment damage.
- Read and understand this manual completely before attempting operation of the railgear equipped vehicle.
- Operating instructions provided below only address the RAFNA railgear equipment. Applicable railway company procedures and policies must be adhered to.
- Railway company rules governing rail travel must be observed at all times.
- Ensure that the position and function of all railgear controls are known before attempting operation.
- Ensure the railgear is locked in road position before starting road travel.
- Ensure all body parts and loose clothing are clear of any moving parts of the equipment.
- If misalignment of the railgear equipment is indicated, promptly perform the alignment procedure.
- Before performing any work under the vehicle or railgear, ensure the engine is turned off and the parking brake is set.
- Never operate the vehicle if the Gross Vehicle Weight Rating (GVWR), Gross Axle Weight Rating Front or Rear (GAWR), or the wheel or tire load ratings are exceeded.
- Always disconnect the vehicle's battery when welding on the vehicle or railgear in order to protect the vehicle's electrical system.

OPERATION OF VERTICAL FRONT RAILGEAR KIT

With the front railgear kit installed on this vehicle, it may be operated as normal, however the front bumper is located further forward than standard. Side wands are located on the front bumper to aid in determining the length and width of the vehicle. The vehicle has decreased ground clearance, and angles of approach and departure due to the railgear. Caution must be used when operating the vehicle.

Never operate the vehicle if the Gross Vehicle Weight Rating (GVWR), Gross Axle Weight Rating Front or Rear (GAWR), or the wheel or tire load ratings are exceeded.

Refer to the Hydraulic Kit Operation, Service, and Parts manual for information on the location and operation of the railgear hydraulic system controls.

Placing the Vehicle on Rail - To Lower the Railgear:

1. Engage the vehicle front axle lock as per the Front Axle Lock Kit Operation, Service and Parts Manual.
2. Disengage the railgear lock hook by pushing the lock hook handle in towards the vehicle to the disengaged position. Do not force the handle. If the lock hook cannot be disengaged, raise the railgear slightly.
3. Hold the lock hook handle in the disengaged position.
4. Lower the railgear. Release the lock hook handle once the railgear has lowered past the road locked position.
5. As the railgear is being deployed, it will start taking the vehicle's load. (If this is not the case, **DO NOT use the railgear**. Inspect the railgear for lubrication and damage.)
6. Continue lowering the railgear until the hydraulic cylinders are fully extended. The vehicle front tires should be minimally 1.5" above the rail per AREMA Standards. (American Railway Engineering and Maintenance-of-Way Association, Maintenance-of-Way Work Equipment, AREMA Manual for Railway Engineering, 2006, Section 2.7.18, Point C)
7. Ensure that the vehicle front axle lock is fully engaged.

Removing the Vehicle from Rail - To Raise the Railgear:

1. Raise the railgear fully. The railgear lock hook should engage automatically.
2. Ensure that the railgear lock hook is engaged and that the railgear is locked in the road position.
3. Disengage the vehicle front axle lock as per the Front Axle Lock Kit Operation, Service and Parts Manual.

SERVICE OF VERTICAL FRONT RAILGEAR KIT

The railgear kit must be serviced regularly to avoid damage to the equipment. Table 2 below provides the Recommended Service Schedule and the detailed service procedures follow.

Figure 4 provides the Non-Standard Fastener Torque Values. Table 3 provides Standard Fastener Torque Values for all other fasteners.

Grease fittings are provided at all railgear lubrication points as shown in Figure 5. The recommended lubricant for all lubrication points on this railgear is **MYSTIK JT-6 LOW TEMP GREASE** or equivalent. In cold weather areas/seasons, **SHELL DARINA XL102** or equivalent may be used.

Table 2: Recommended Service Schedule

Service Required	Daily	Weekly	Monthly	3 Months	6 Months	12 months
Visually inspect the railgear for damaged or worn parts	✓	✓	✓	✓	✓	
Check for loose rail wheels and fasteners (re-torque if required)	✓	✓	✓	✓	✓	
Ensure railgear lock pin is functioning correctly	✓	✓	✓	✓	✓	
Ensure the vehicle is in good operating condition	✓	✓	✓	✓	✓	
Inspect the rail wheel flanges for wear (use Rafna wear gauge)				✓	✓	
Inspect all hydraulic components for leaks or wear	✓	✓	✓	✓	✓	
Check and adjust rail sweeps			✓	✓	✓	
Grease railgear inner and outer guide tubes		✓	✓	✓	✓	
Grease railgear inner tube lower pivot point			✓	✓	✓	
Grease railgear locking pin			✓	✓	✓	
Check and adjust rail wheel bearing end-play			✓	✓	✓	
Grease rail wheel bearings (every 3000 rail kms or 1900 rail miles)				✓	✓	✓
Check and adjust rail wheel load						✓
Check and adjust rail wheel alignment						✓
Check and repack rail wheel bearings						✓
Check and adjust vehicle front tire clearance					✓	

Table 3: Standard Fastener Torque Values

Fastener Size	Fastener Torque Value (ft-lbs.) Dry
1" UNC GR.8 Fasteners	250
3/4" UNC GR.8 Fasteners	175
5/8" UNC GR.8 Fasteners	150
1/2" UNC GR.8 Fasteners	100
3/8" UNC GR.8 Fasteners	40
1/4" UNC GR.8 Fasteners	12

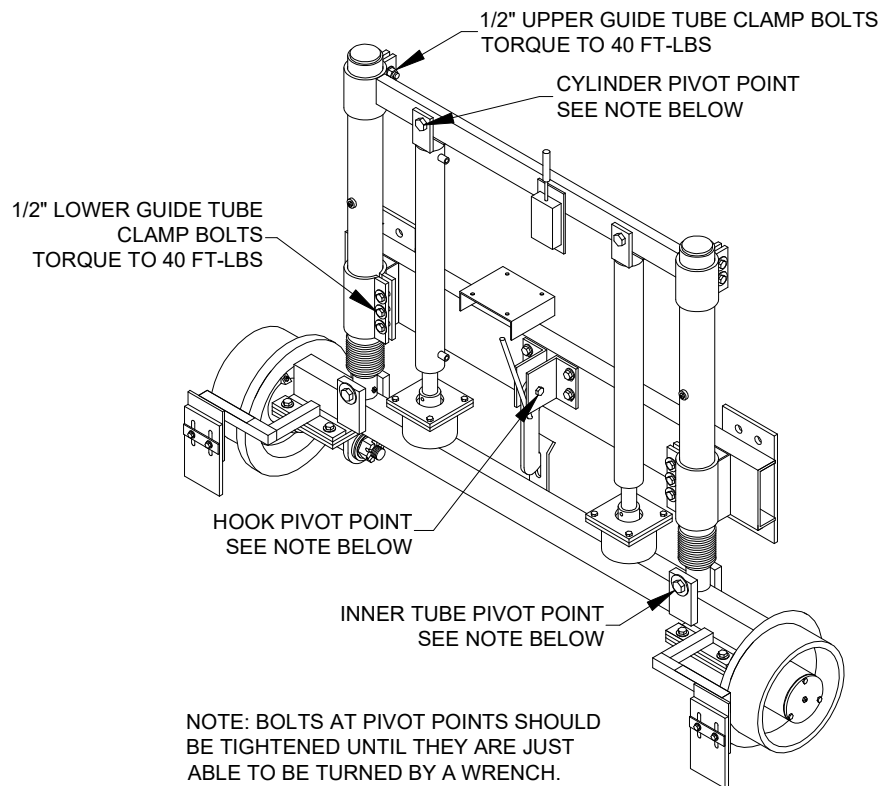

Figure 4: Non-Standard Fastener Torque Values

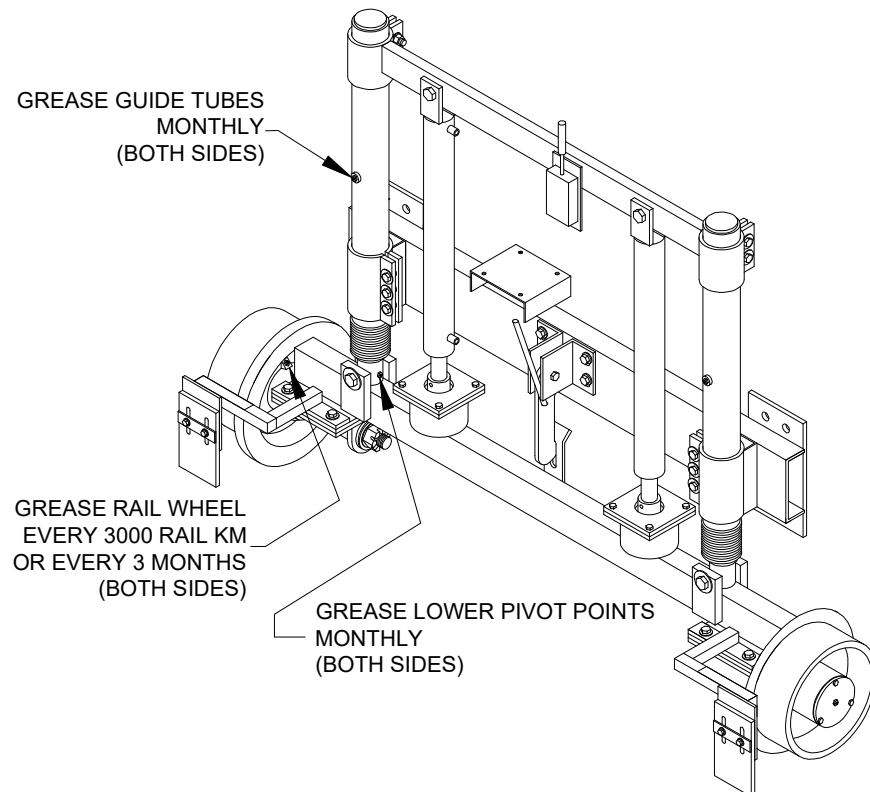

Figure 5: Railgear Lubrication Points

RAIL WHEEL BEARING ADJUSTMENT

The rail wheel bearings require periodic adjustment to keep the endplay within specification. If the rail wheel bearings are not correctly adjusted, failure may occur and will not be covered under the railgear warranty. Check and adjust the bearing endplay with the railgear in the road position and with the rail wheels free to turn.

Use a magnetic base dial gauge to measure the endplay of each rail wheel bearing. The bearing endplay must be between 0.001" and 0.005". If this is not the case, adjust as follows:

1. Remove the rail wheel hubcap and gasket by removing the three 1/4" bolts and 1/4" lock washers. Remove and discard the cotter pin from the 3/4" slotted spindle nut.
2. Ensure the wheel-bearing cavity is full of grease.
3. While rotating the rail wheel forward, torque the spindle nut to 20 ft-lbs. Then loosen the spindle nut and re-torque it to 6 ft-lbs. Re-check and re-adjust the bearing endplay if required. If no torque wrench is available, tighten the spindle nut until the rail wheel is difficult to turn by hand. Then loosen the spindle nut and retighten it just until no loose can be felt in the bearings. Re-adjust the bearing endplay with a torque wrench as soon as possible.
4. Install a new 3/16" x 2" long cotter pin through the spindle nut. Tighten the spindle nut slightly if needed to insert the cotter pin.
5. Re-install the hubcap and gasket using the 1/4" bolts and new 1/4" split lock washers. Blue Loctite can be used on the bolts as an added safety measure. Tighten and torque the 1/4" fasteners to 12 ft-lbs dry. Do not over torque.

RAIL SWEEP ADJUSTMENT:

The distance between the rail sweep rubber and the rail is adjustable and should be maintained at approximately 1/8". To adjust the rail sweep rubber, with the railgear in the rail position, loosen the two 1/4" fasteners that secure the rail sweep rubber to the rail sweep bracket. Slide the rail sweep rubber up or down for the correct clearance. Tighten and torque the 1/4" fasteners to 12 ft-lbs dry. Do not over torque.

VEHICLE FRONT TIRE CLEARANCE ADJUSTMENT

The vehicle front tires must remain at a minimum height above the rail to ensure sufficient clearance when travelling on rail. Both the setting of the front axle lock and the position of the railgear within the lower guide tube clamps affect the clearance height. If the front tires are less than 1.5" from the rails when the railgear is in the rail position per AREMA Standards (American Railway Engineering and Maintenance-of-Way Association, Maintenance-of-Way Work Equipment, AREMA Manual for Railway Engineering, 2006, Section 2.7.18, Point C) OR the front rail wheels are less than 7" from the ground when the railgear is in the road position, the front tire clearance must be adjusted as follows:

1. Ensure that the vehicle front axle lock is correctly adjusted as per the Front Axle Lock Operation, Service and Parts manual.
2. Determine how much the railgear must be adjusted up or down in order to obtain the correct road and rail clearance.
3. With the railgear in the road position, support the railgear axle. Loosen the six 1/2" fasteners that hold the outer guide tubes within the lower outer guide tube clamps.
4. Adjust the railgear height as required by sliding the railgear up or down within the outer guide tube clamps.
5. Re-torque the 1/2" fasteners to 40 ft-lbs dry. Do not over torque.
6. Ensure that the railgear will not contact any vehicle components throughout the full range of railgear and railgear suspension movement.
7. Re-check the road and rail clearances and re-adjust if necessary.

NOTE

If the correct height cannot be achieved using the clamps, the railgear mounting height must be adjusted. Support the railgear and remove the 3/4" fasteners that hold the railgear on the front mounting plates. Raise the railgear so that the next set of railgear mounting holes align with the mounting plate slots. Re-install the 3/4" fasteners and torque them to 175 ft-lbs dry. Do not over torque. Follow the Railgear Alignment procedure provided in this manual.

8. Re-adjust the railgear lock system if necessary as per the Railgear Lock System Adjustment procedure provided in this manual.
9. Ensure that the collars are welded onto the railgear outer guide tubes so that they are tight against the upper cross frame clamps.

RAILGEAR LOCK SYSTEM ADJUSTMENT

The front railgear lock system provides a mechanical locking hook to hold the railgear axle in the road position. For the system to function properly, the hook must be able to engage and disengage easily from the latch without any obstructions. If the hook is not aligned with the latch, the hook position can be adjusted as follows:

1. Remove the 1/2" fastener holding the hook between the hook supports.
2. Align the hook with the upper, middle or lower set of holes in the hook supports as required.
3. Re-install the 1/2" fastener. Tighten but do not torque this fastener, as the hook must be free to swing.
4. Loosen the four 3/8" fasteners that hold the hook supports on the railgear.
5. Slide the hook supports up or down on the railgear as necessary to align the hook with the hook latch.
6. Torque the four 3/8" fasteners that hold the hook supports to the railgear to 40 ft-lbs dry. Do not over torque.
7. Ensure that the hook can engage and disengage freely without any obstructions. If further adjustment is required, repeat the above steps.

RAILGEAR ALIGNMENT

The railgear must be correctly aligned to perform properly, safely, and avoid excessive wear and derailment. The rail wheels can be independently aligned for toe-in/toe-out and the railgear can be adjusted side to side (laterally) on the vehicle. A parallel line system and the following procedure should be used to perform the railgear alignment.

The vehicle front tire clearance adjustment procedure must be completed, the vehicle should have had a four-wheel alignment (with the complete railgear package installed on the vehicle and any suspension modifications done) and the tires should be properly inflated prior to performing the railgear alignment.

The railgear alignment is done with the vehicle on a straight and level section of rail with the railgear in the rail position and the vehicle wheels pointing straight ahead. The individual rail wheel alignment should be done first, followed by the lateral alignment of the railgear.

Loosening the four 1/2" fasteners that secure it to the railgear axle aligns each rail wheel. The rail wheel is then turned into alignment. The four 1/2" fasteners should then be tightened and torqued to 100 ft-lbs. dry. Do not over torque.

The railgear is aligned laterally by loosening the four 3/4" fasteners that secure it to the railgear mounting plates. The railgear is then moved sideways into alignment. It may be necessary to raise the railgear off the rails to move the railgear side to side. Do not use any force against the railgear guide tubes as this may damage them and restrict suspension movement. The four 3/4" fasteners should then be tightened and torqued to 175 ft-lbs dry. Do not over torque.

Refer to Figure 4 for alignment measurement and specifications. Use an 18" magnetic straight edge on the back of each rail wheel to measure from.

Following the railgear alignment, the railgear may contact the vehicle if not enough clearance was left during installation. Check the railgear clearance to all vehicle components throughout the full range of railgear and railgear suspension movement. If there is interference with the vehicle's bumper, it can be trimmed and reinforced as required. If there is interference with the vehicle's exhaust system, it can be bent to fit, ensuring any exhaust system modifications conform to applicable laws and regulations. If there is interference with any other vehicle components, please call G&B Specialties Inc. for technical assistance.

WHEEL WEAR STANDARDS AND RECOMMENDATIONS

At the present time, G&B produces 8”, 10”, 12”, 14”, and 16” steel wheels. Each size has a different flange and tread thickness, which dictates the allowable wear. Although the following numbers are recommended limits, risk of failure is increased when not followed. Rail gauge can be supplied by G&B Specialties for 8”, 10”, 12”, 14”, and 16” rail wheels. They are used as go/no go gauges. When placed on rail wheels they will indicate how much wear is still permissible or if the rail wheels need to be replaced.

The gauge for the R-450 model railgear can be ordered using the following part number; S-001200

- Rail wheel failure can result in equipment damage or failure, personal injury, or death.

Flange Wear Limits:

The maximum flange wear is indicated on the rail wheel gauge. When the gauge is placed on the rail wheel, if a gap is seen between the gauge and the maximum flange wear line, the rail wheel needs to be replaced.

Tread Wear Limits:

For tread wear, use the following chart in conjunction with the appropriate rail wheel gauge.

NOMINAL RAIL WHEEL DIAMETER (INCHES)	MIN. ALLOWABLE WHEEL DIAMETER (INCHES)
10	9 3/4

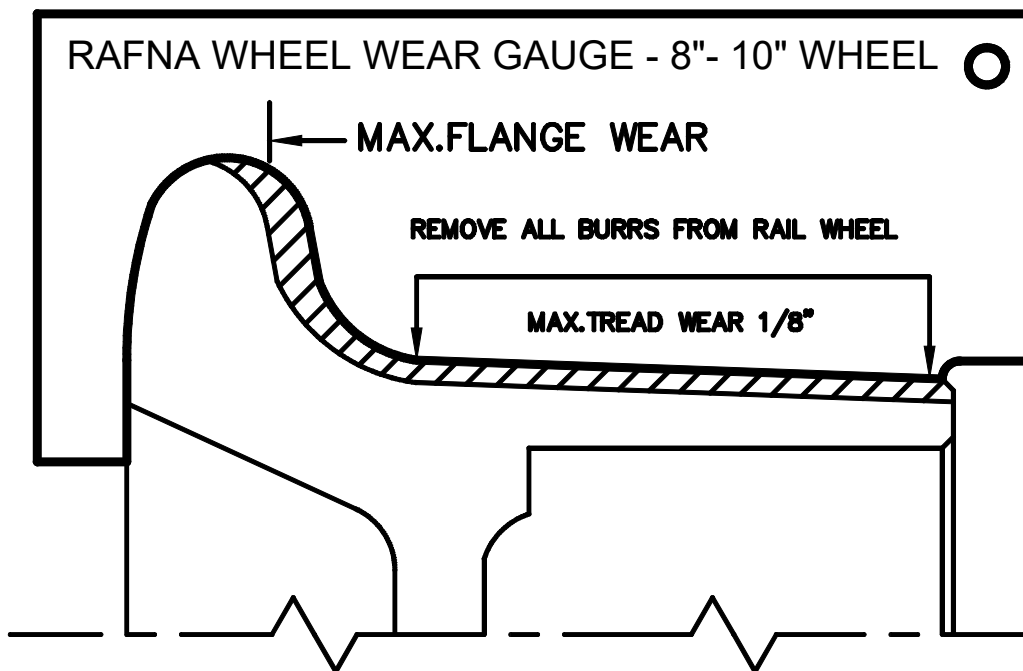

RAFNA RAILGEAR ALIGNMENT RACK DATA

GAS OR DIESEL _____ VIN# _____

VEHICLE MAKE: _____ VEHICLE MODEL: _____ VEHICLE YEAR: _____

DOOR STICKER GVWR: _____ DOOR STICKER GAWR FRT: _____ DOOR STICKER GAWR RR _____

RAILGEAR S/N: FRT _____ RR _____ VEHICLE UNIT #,S/N: _____

RAILGEAR TYPE: _____ INSTALLER: _____ DATE: _____

SET UP PARALLEL STRING LINES
A & B MUST BE EQUAL WITHIN 1/32"
C & D MUST BE EQUAL WITHIN 1/32"

ADJUST STRING LINES AROUND VEHICLE
E, F, G, & H MUST BE EQUAL WITHIN 1/16"
I, J, K, & L MUST BE EQUAL WITHIN 1/16"
(E, F, G, & H MAY NOT EQUAL I, J, K, & L)

ADJUST RAIL WHEEL ALIGNMENT
M & O MUST BE EQUAL WITHIN 1/16"
N & P MUST BE EQUAL WITHIN 1/16"
Q & S MUST BE EQUAL WITHIN 1/16"
R & T MUST BE EQUAL WITHIN 1/16"

ADJUST RAILGEAR LATERAL ALIGNMENT
M & O MUST EQUAL N & P WITHIN 1/8"
Q & S MUST EQUAL R & T WITHIN 1/8"

ENSURE THAT U & V ARE BETWEEN
53- 7/16" AND 53-9/16"

OVER-CENTER ANGLE (DEGREE)
FRONT _____
REAR _____

RAIL WHEEL LOADS (LBS)
LEFT FRONT _____ RIGHT FRONT _____
LEFT REAR _____ RIGHT REAR _____

RAIL WHEEL FLANGE TO GROUND CLEARANCE
LEFT FRONT _____ RIGHT FRONT _____
LEFT REAR _____ RIGHT REAR _____

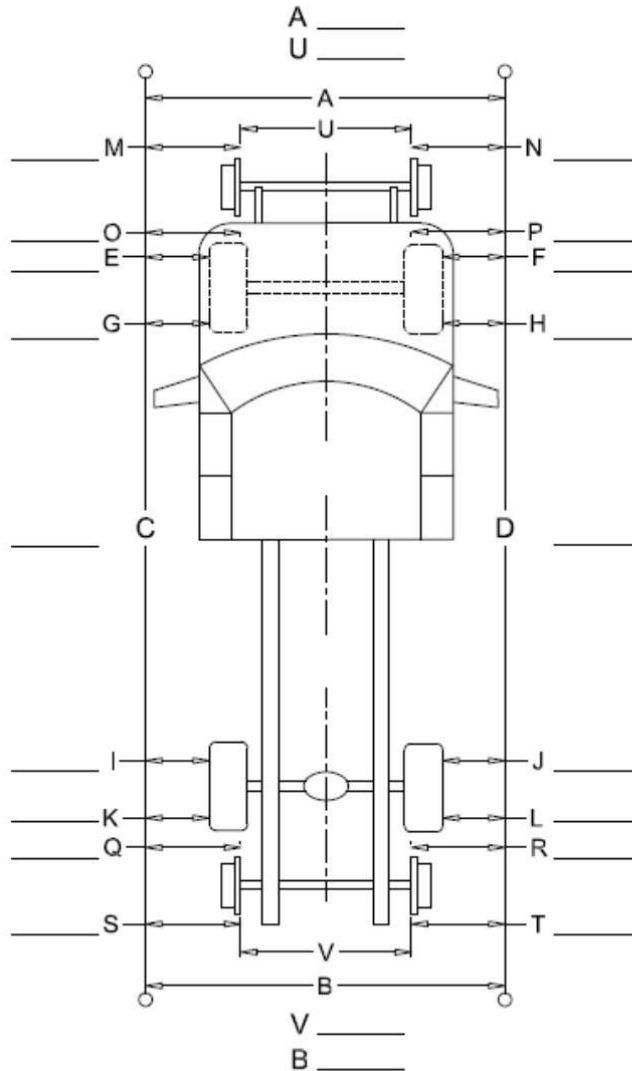

MOUNTING HEIGHT FRONT: _____ MOUNTING HEIGHT REAR: _____

STOCK TURNING DIAMETER: _____ MODIFIED TURNING DIAMETER: _____

OEM: VEHICLE WEIGHT: _____ FRONT GAWR: _____ REAR GAWR: _____

MODIFIED: VEHICLE WEIGHT: _____ FRONT GAWR: _____ REAR GAWR: _____

FAX COMPLETED FORM TO JAKE SANUTE AT FAX # 570-802-0491

MAY 31, 2018 REV "D"

Figure 6

RAFNA RAILGEAR PORTABLE ALIGNMENT DATA

GAS OR DIESEL _____ VIN# _____

VEHICLE MAKE: _____ VEHICLE MODEL: _____ VEHICLE YEAR: _____

DOOR STICKER GVWR: _____ DOOR STICKER GAWR FRT: _____ DOOR STICKER GAWR RR _____

RAILGEAR S/N: FRT _____ RR _____ VEHICLE UNIT #,S/N: _____

RAILGEAR TYPE: _____ INSTALLER: _____ DATE: _____

ADJUST RAILGEAR LATERAL ALIGNMENT
A MUST EQUAL B WITHIN 1/8"
C MUST EQUAL D WITHIN 1/8"

ENSURE THAT U & V ARE BETWEEN
53—7/16" AND 53—9/16"

OVER-CENTER ANGLE (DEGREE)
FRONT _____
REAR _____

RAIL WHEEL LOADS (LBS)
LEFT FRONT _____ RIGHT FRONT _____
LEFT REAR _____ RIGHT REAR _____

RAIL WHEEL FLANGE TO GROUND CLEAR-
ANCE
LEFT FRONT _____ RIGHT FRONT _____
LEFT REAR _____ RIGHT REAR _____

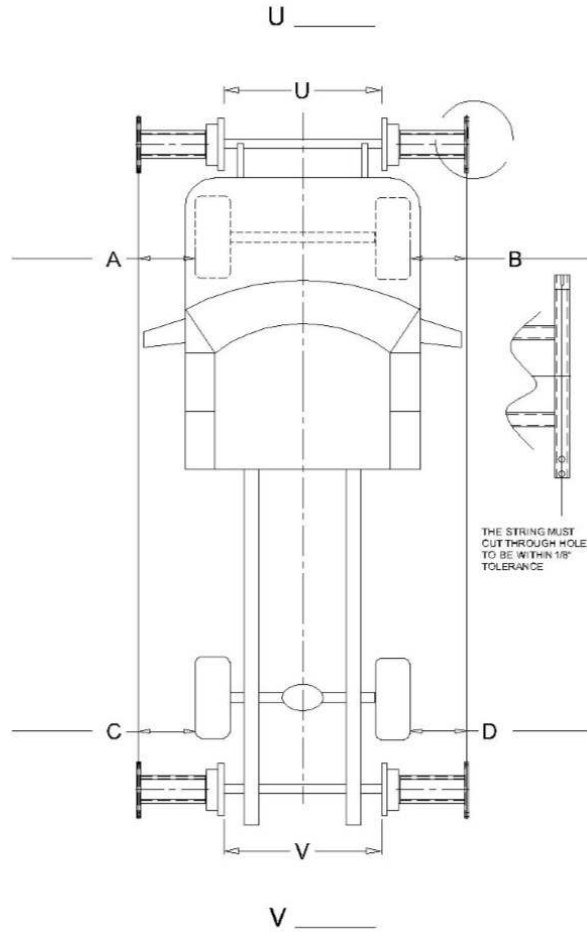

MOUNTING HEIGHT FRONT: _____ MOUNTING HEIGHT REAR: _____

STOCK TURNING DIAMETER: _____ MODIFIED TURNING DIAMETER: _____

OEM: VEHICLE WEIGHT: _____ FRONT GAWR: _____ REAR GAWR: _____

MODIFIED: VEHICLE WEIGHT: _____ FRONT GAWR: _____ REAR GAWR: _____

FAX COMPLETED FORM TO JAKE SANUTE AT FAX # 570-802-0491

MAY 31, 2018 REV B

Figure 7

PARTS OF R-450 VERTICAL FRONT RAILGEAR KIT

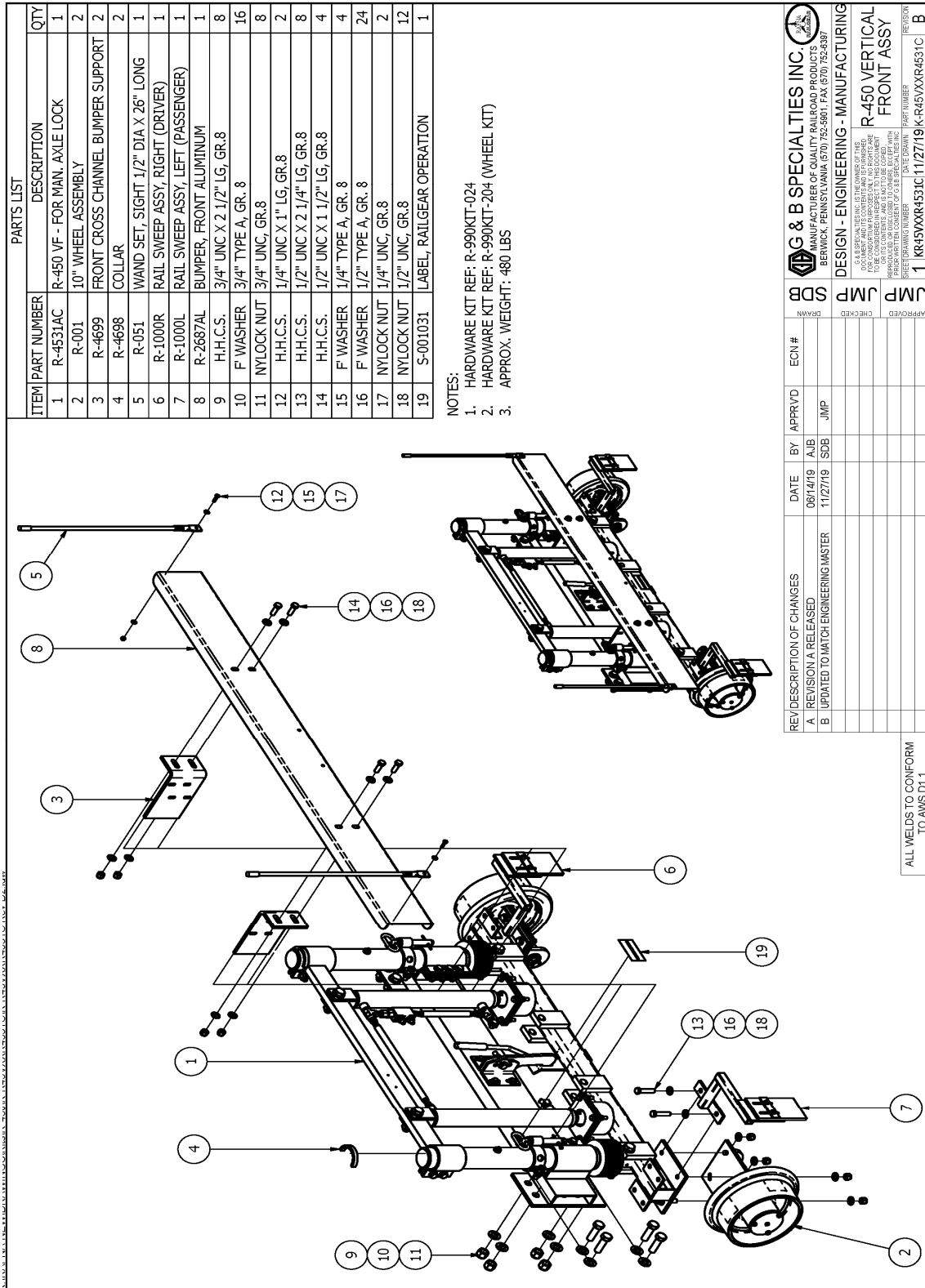

Figure 8: K-R45VXXR4531C Sheet 1 (Vertical Front Railgear Top Level Assembly)

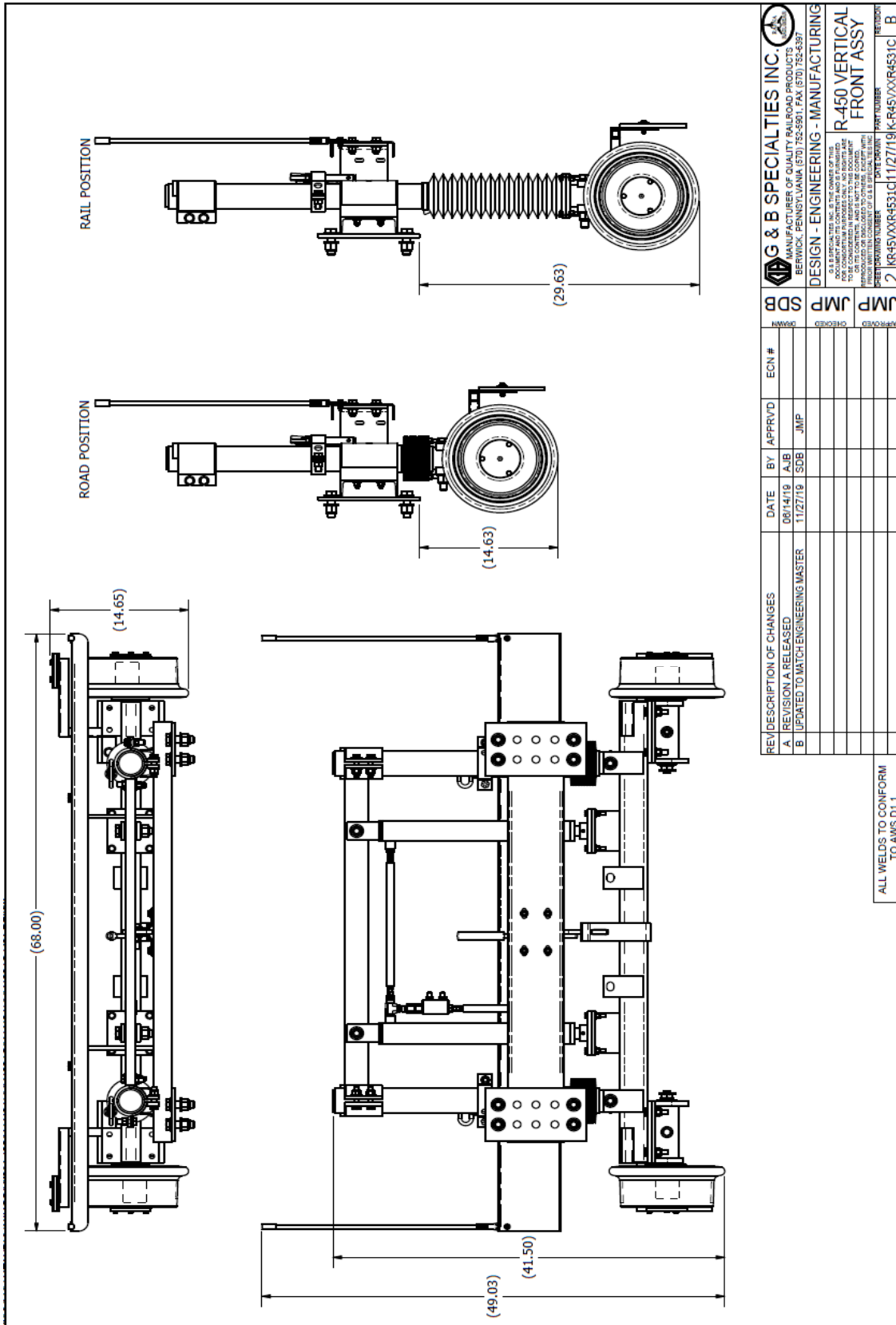

Figure 9: K-R45VXXR4531C Sheet 2 (Vertical Front Railgear Top Level Assembly)

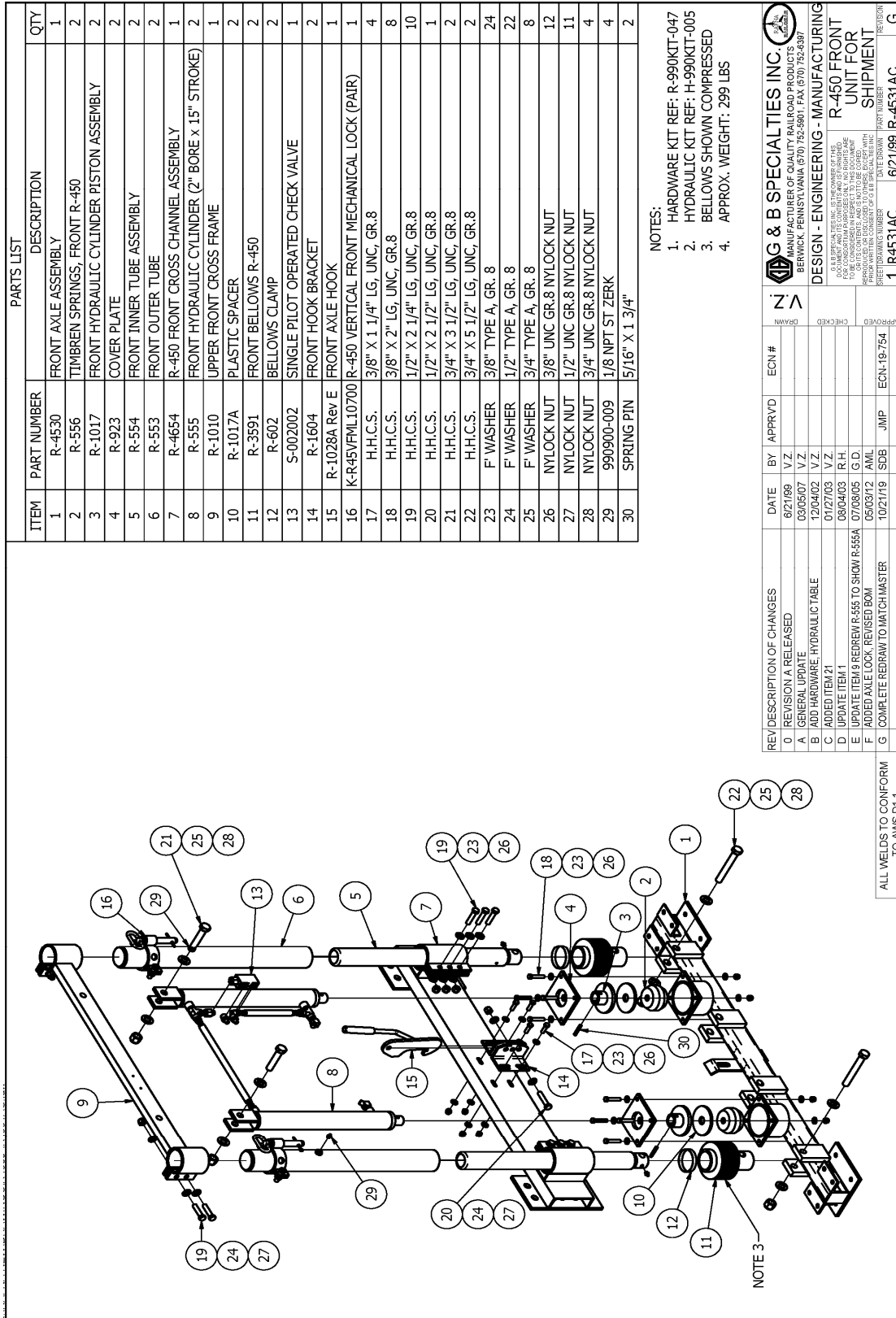

Figure 10: R-4531AC Sheet 1 (Railgear Upper Assy)

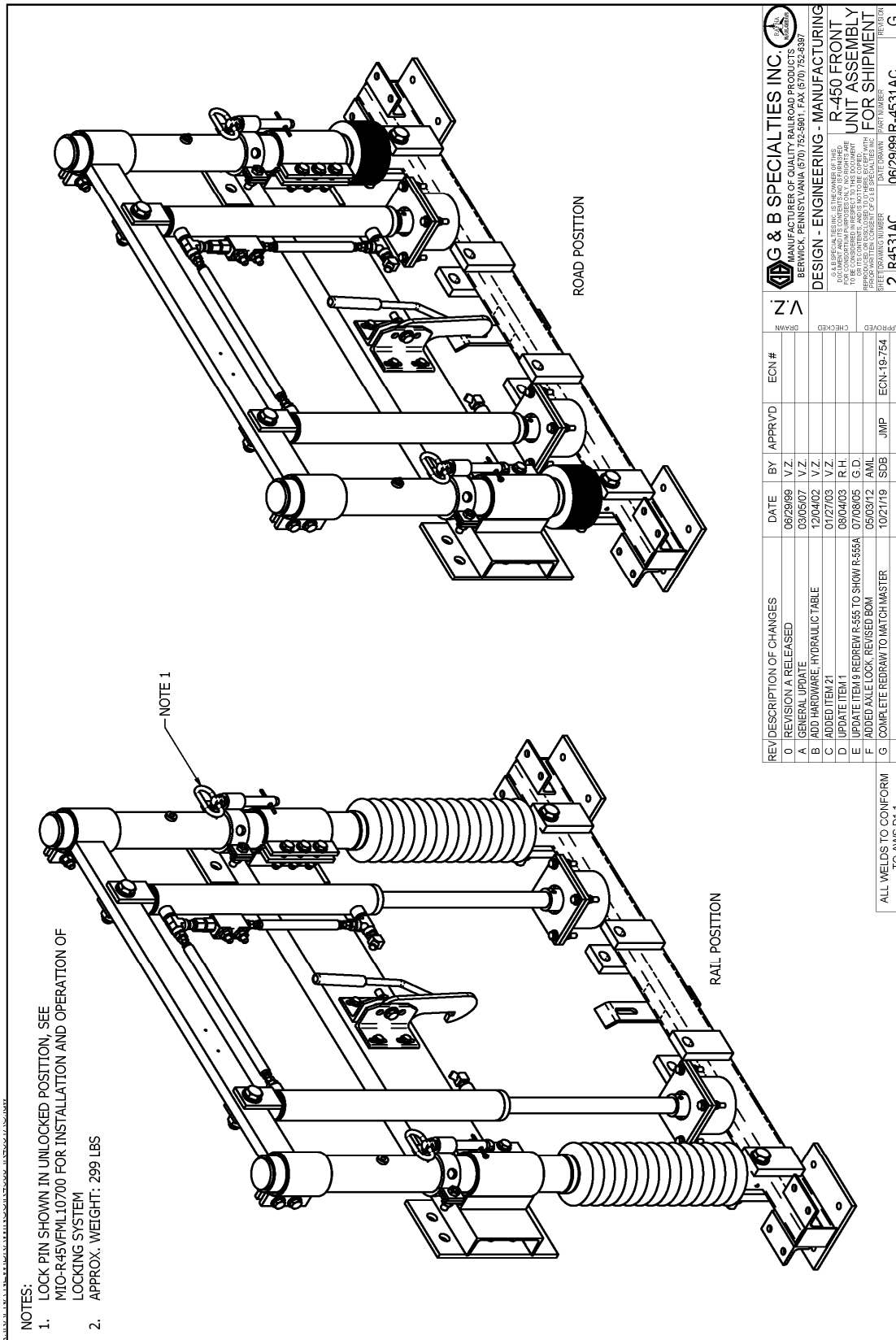

Figure 11: R-4531AC Sheet 2 (Railgear Upper Assy)

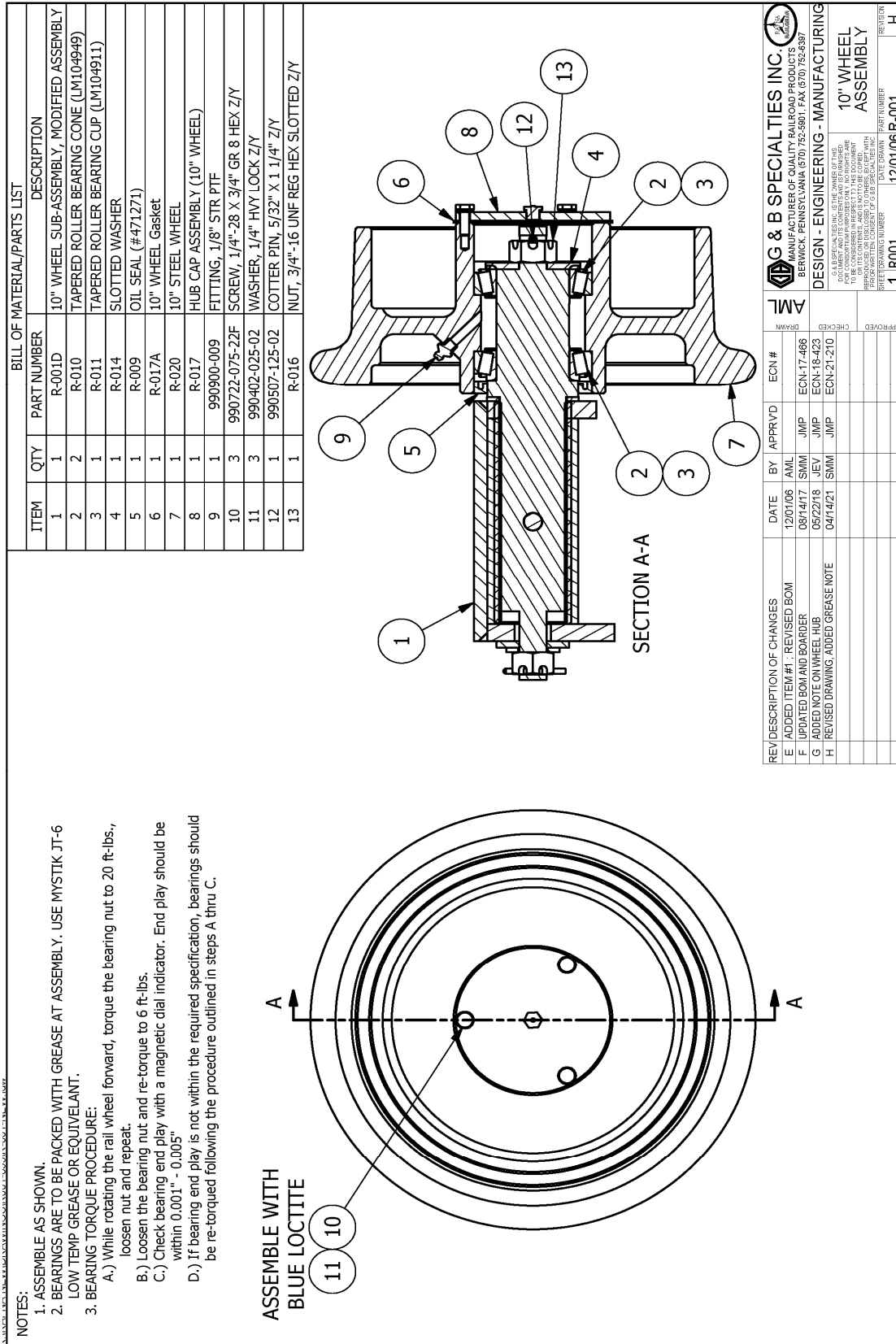

Figure 12: R-001 (Rail Wheel Assembly)

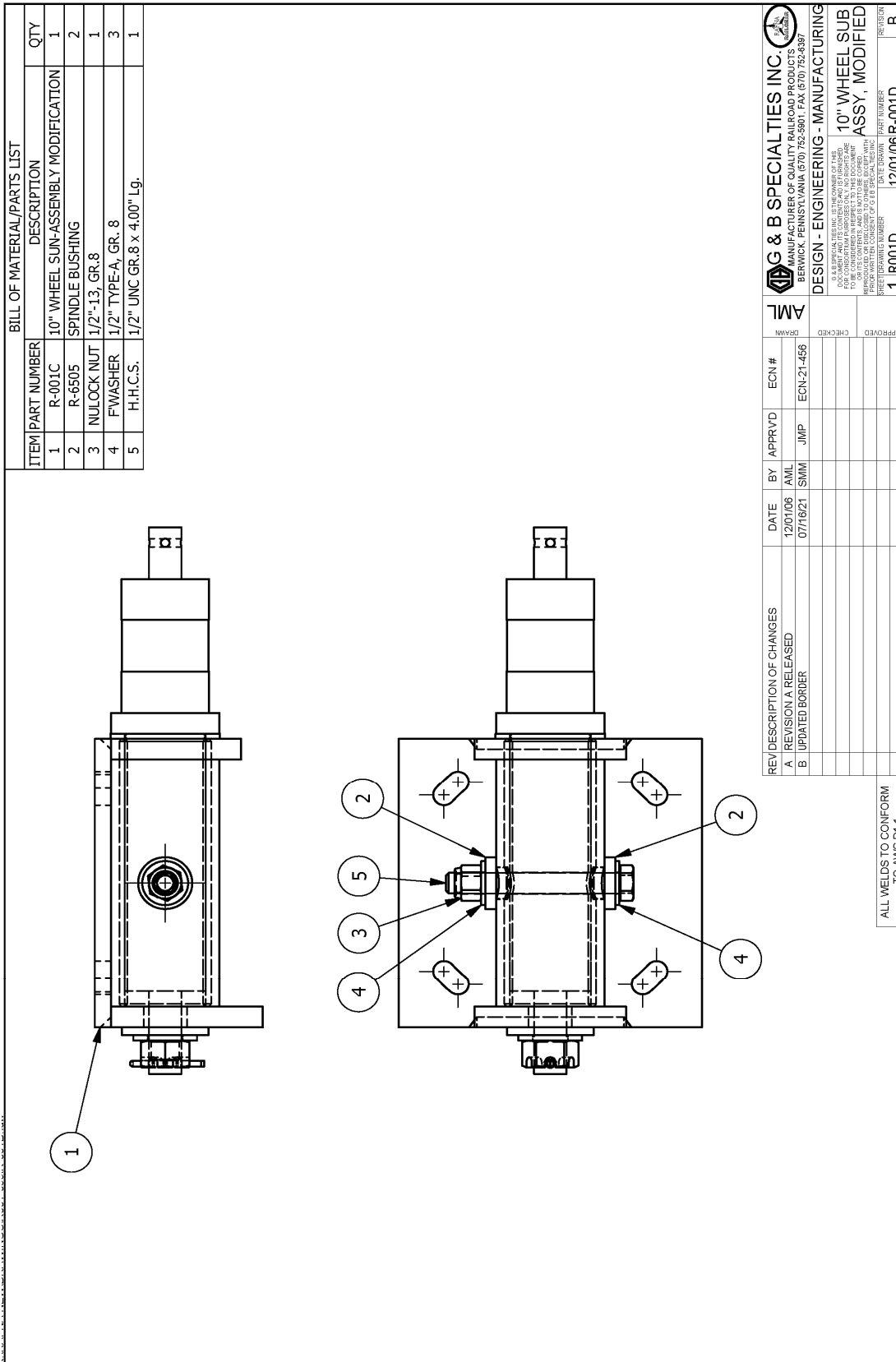

Figure 13: R-001D (Spindle Assy Complete)

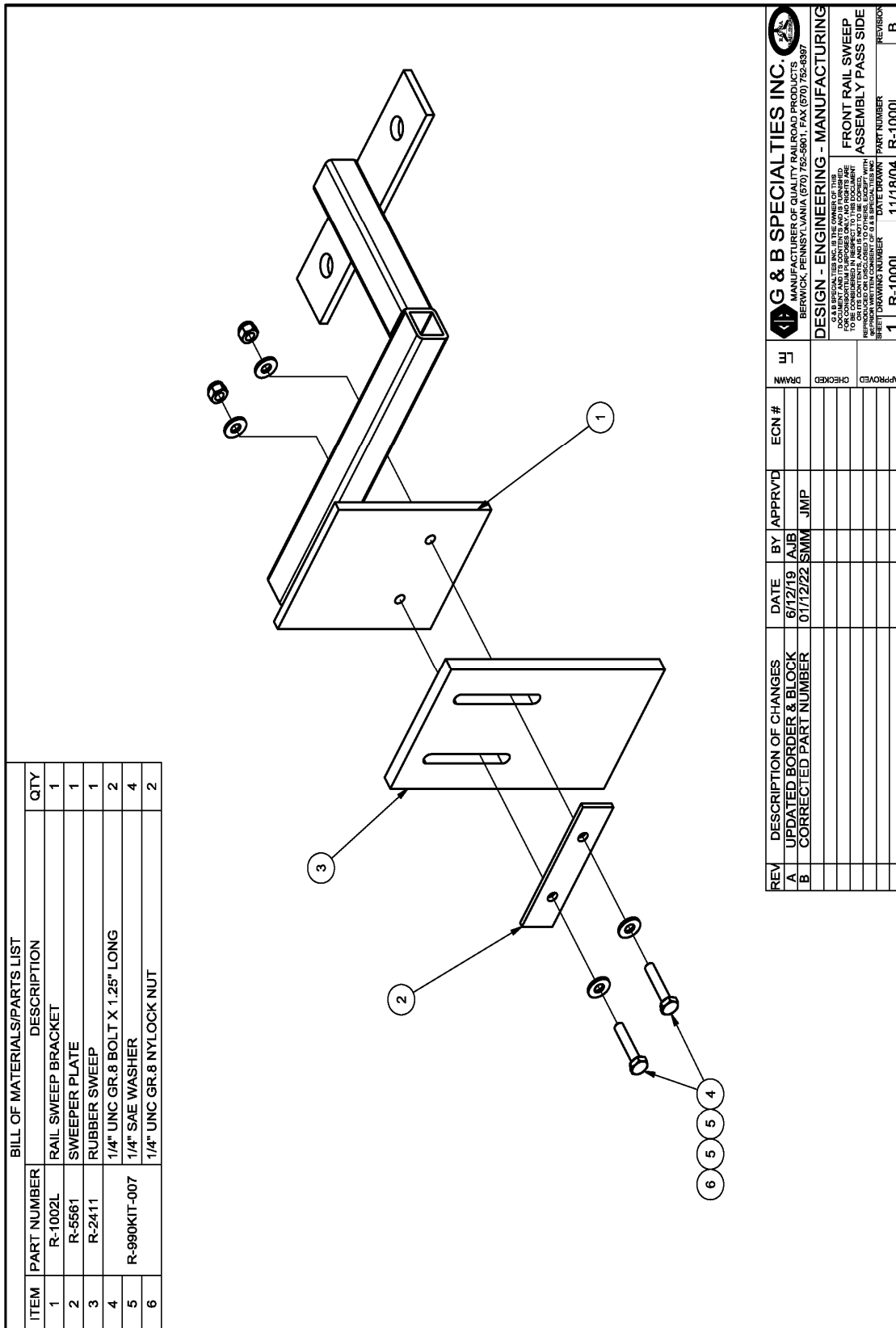

Figure 14: R-1000L (Passenger Rail Sweep)

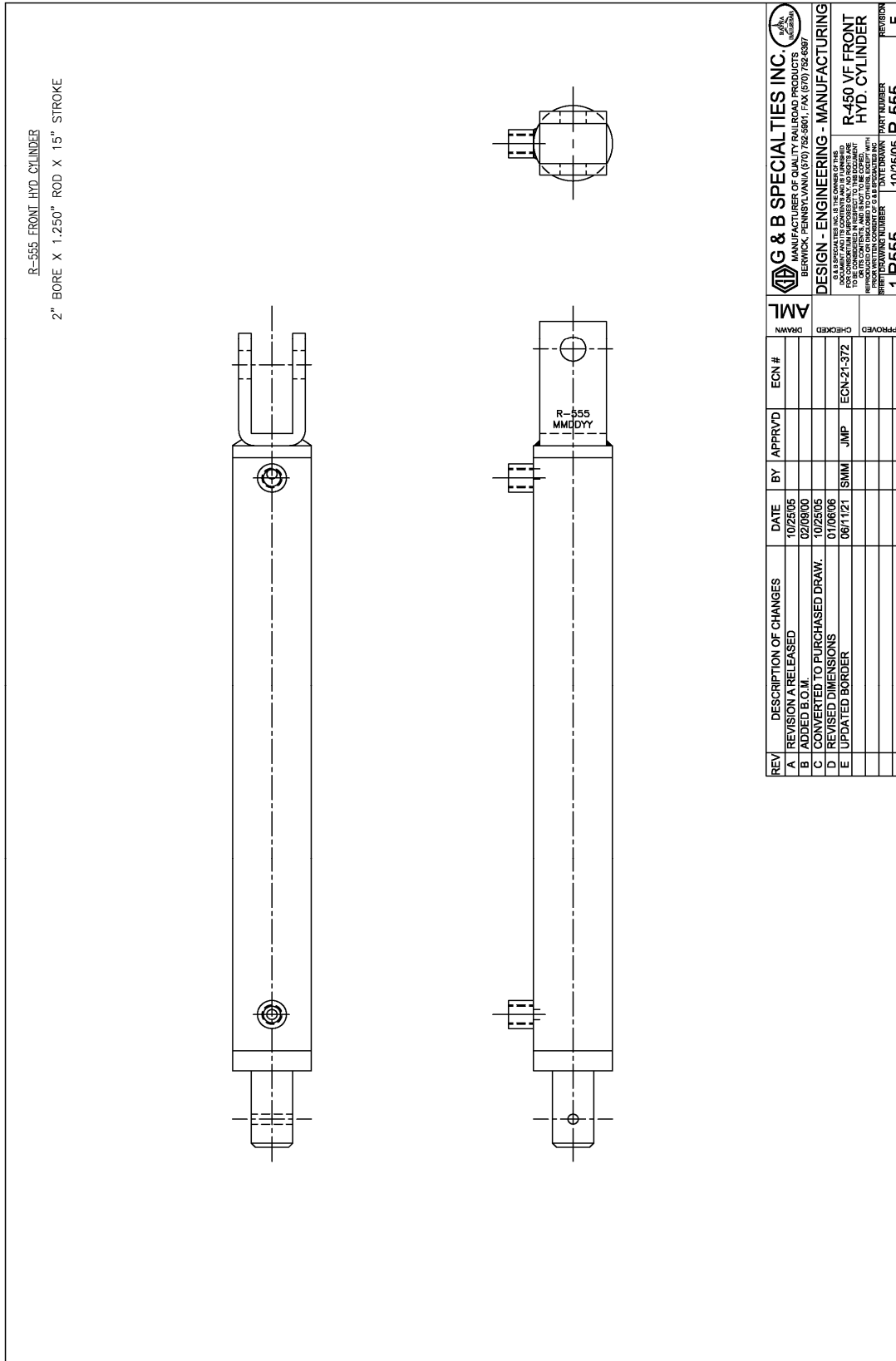

Figure 16: R-555 (Hydraulic Cylinder)

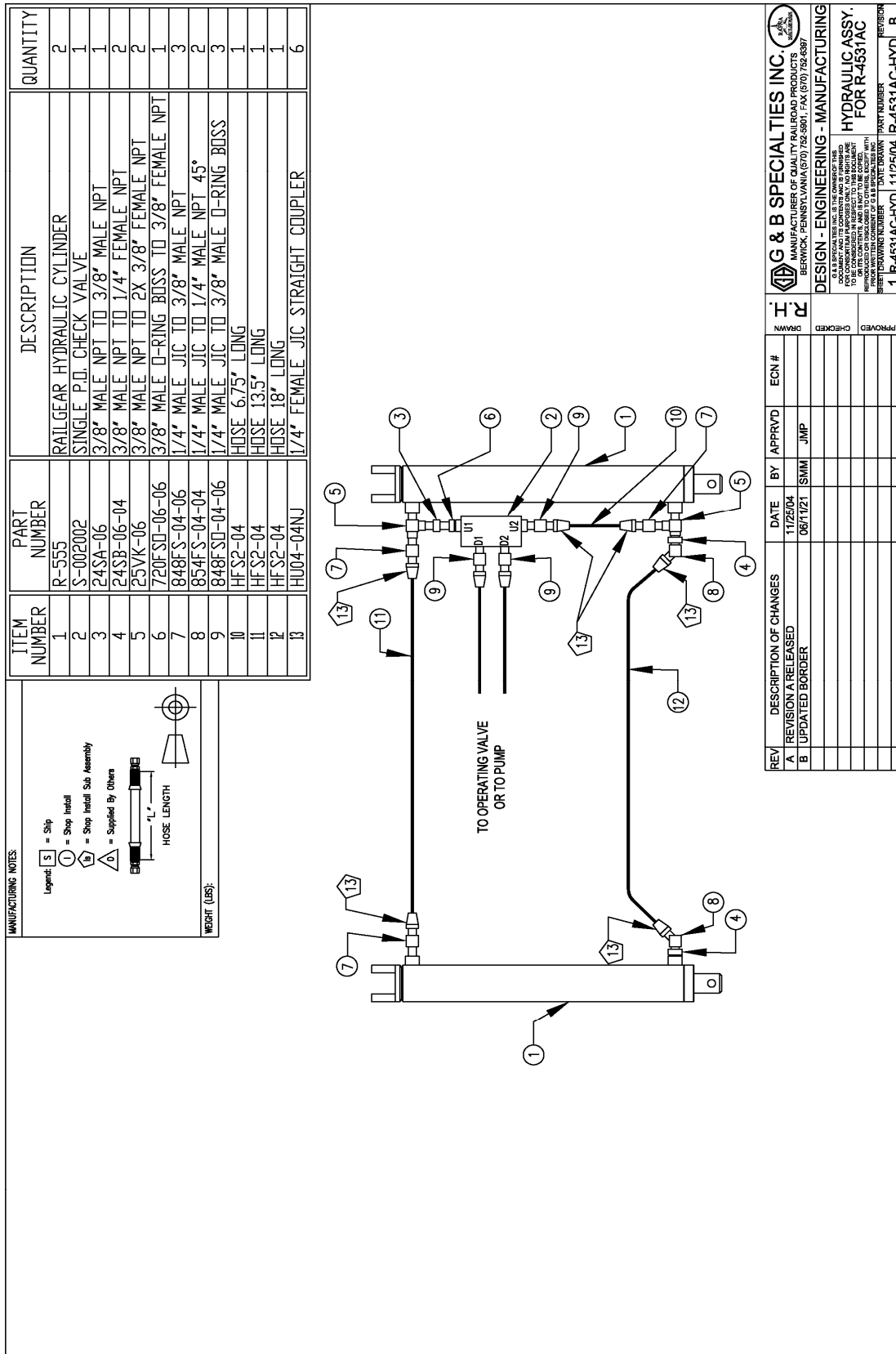

Figure 17: Hydraulic Schematic (H-990KIT-005)