

R-307A MANUAL RAILGEAR

OPERATOR'S SERVICE AND PARTS MANUAL

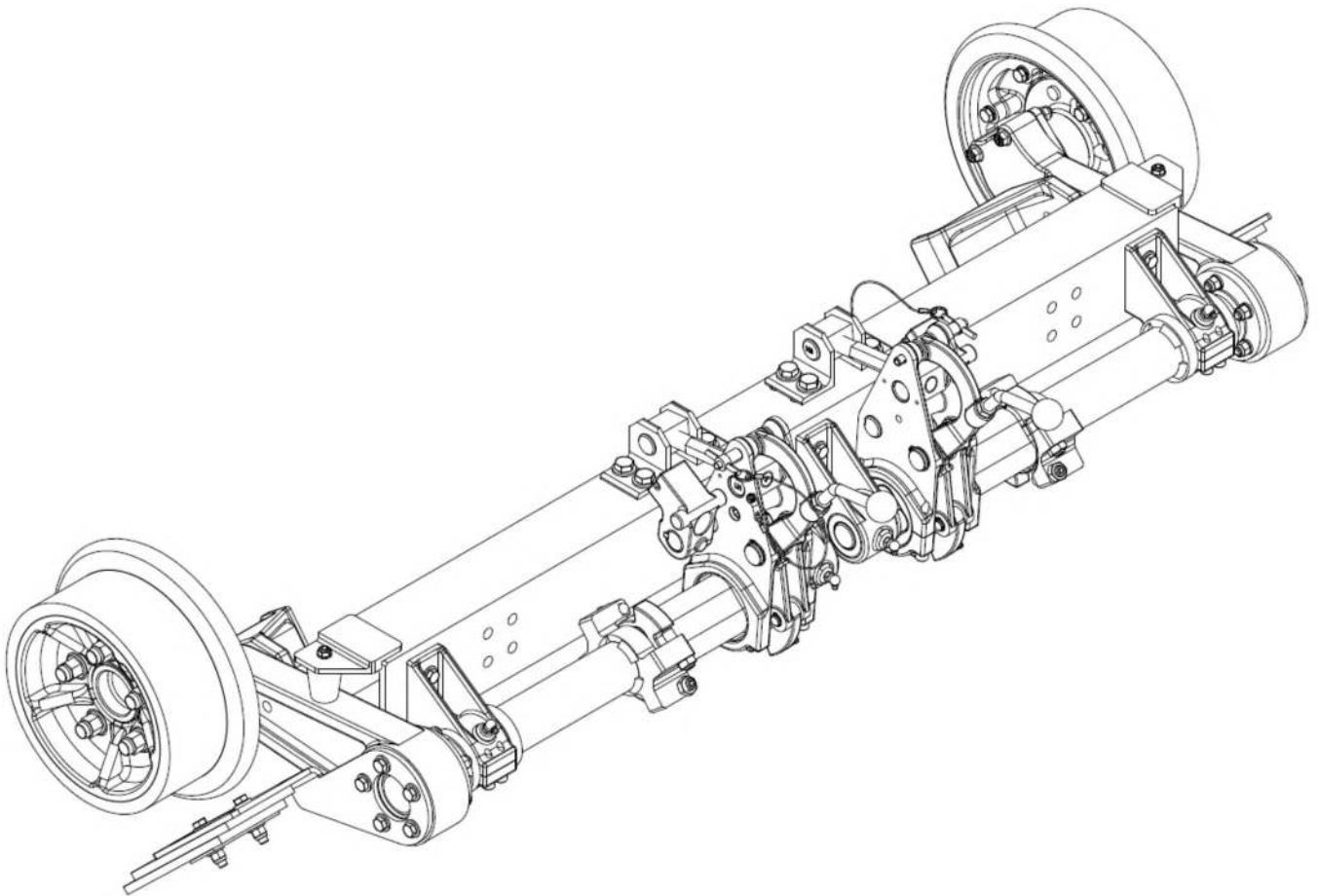

INSTALLATION SAFETY PRECAUTIONS

If any installation problems are encountered, please call G&B Specialties, Inc. for technical assistance before continuing with the installation process.



- Failure to heed to any of the following warnings could result in severe bodily injury and/or equipment damage.
- Read and understand this manual completely before attempting installation of the equipment.
- Installation instructions provided below only address the RAFNA railgear equipment. Applicable railway company procedures and policies must be adhered to.
- Before performing any work under the vehicle or railgear, ensure the engine is turned off and the parking brake is set.
- Beware of all pinch points on the railgear and keep all parts of the body clear.
- Ensure all removed components are given to the vehicle owner after the installation of the railgear. These components must be re-installed if the railgear is removed from the vehicle.
- Always disconnect the vehicle's battery when welding on the vehicle or railgear in order to protect the vehicle's electrical system.
- Railway Company rules governing rail travel must be observed at all times.
- Never operate the vehicle if the Gross Vehicle Weight Rating (GVWR), Gross Axle Weight Rating Front or Rear (GAWR), or the wheel or tire load ratings are exceeded.

Table of Contents

DESCRIPTION

SECTION

SECTION 1.0	5
General Information.....	5
Installation Safety Precautions	5
Description.....	7
Serial Numbers	8
Weight Specifications	9
SECTION 2.0	10
Mounting of Railgear	10
SECTION 3.0	16
Operations	16
Preparing for Operation	16
Placing Vehicle on Track.....	18
Moving on Track.....	26
Removing Vehicle from Track.....	31
Highway Operation	34
SECTION 4.0	38
Railgear Alignment Procedure	38
Guide Wheel Equipment Alignment Procedure	38
Adjustments	56
SECTION 5.0	59
Maintenance	59
Wheel Bolts and Lugs.....	59
Maintenance Schedule	59
Railgear Unit Lubrication	61
Guide Wheels.....	62
Locking Mechanism	64
Pivot Bearings	64
Rubber Cord Replacement.....	64
Vehicle Wheels.....	64
SECTION 6.0	66
Troubleshooting.....	66
Troubleshooting Guide Wheel Equipment.....	66
Warranty	71
G&B Specialties, Inc. Limited Warranty.....	71
Product Improvement Liability Disclaimer	71
Important Notice.....	71
Warranty Policies and Procedures For Installers and Customers.....	72

Installers & Customer Warranty:	72
Additional Billing, Installers & Customers:	72
Warranty Claim information and requirements:	72
Labor Warranty and /or additional labor charges:	73
Faulty Railgear Installations:	73
Parts Warranty:	73
Warranty Claim Form	74
SECTION 7.0	75
Parts	75

1.0 GENERAL INFORMATION

INSTALLATION SAFETY PRECAUTIONS

NOTE

If any installation problems are encountered, please call G&B Specialties, Inc. for technical assistance before continuing with the installation process.

WARNING

Failure to heed to any of the following precautions could result in severe bodily injury and/or equipment damage.

- Read and understand this manual completely before attempting installation of the equipment.
- Installation instructions provided below only address the RAFNA railgear equipment. Applicable railway company procedures and policies must be adhered to.
- Before performing any work under the vehicle or railgear, ensure the engine is turned off and the parking brake is set.
- Beware of all pinch points on the railgear and keep all parts of the body clear.
- Always disconnect the vehicle's battery when welding on the vehicle or railgear in order to protect the vehicle's electrical system.
- Apply the vehicle parking brake and stop the engine when performing maintenance, making adjustments, working under vehicle or guide wheel equipment or whenever unintended movement of the vehicle could occur, unless otherwise instructed in this manual.
- Make sure all persons are clear of vehicle before performing any operating functions.
- Keep all parts of the body and loose clothing clear of all moving parts of the vehicle or guide wheel equipment.
- Understand equipment operation and be aware of all pinch points before operating or making adjustments to guide wheel equipment.
- If a derailment should occur while vehicle is operating in electrified 3rd-rail territory, vehicle or guide wheel equipment might be in electrical contact with electrified rail. Do not attempt to exit from vehicle until electrical power to 3rd-rail has been turned off.
- Do not exceed 35 mph (56 km/h) when operating vehicle on track. Railroad rules governing speeds should be observed at all times. Reduce speed when propelling vehicle through switches, crossings, branch lines and any special track works. Operating vehicle at unsafe speeds could result in derailment of vehicle.
- Check and correct guide wheel equipment alignment promptly if misalignment is indicated.

- At maximum loaded gross vehicle weight on track (including driver, passengers, equipment, tools, payload, etc.) Do not exceed any of the following:
 - o Vehicle's G.V.W.R. (gross vehicle weight rating).
 - o Vehicle's front G.A.W.R. (gross axle weight rating) or the sum of the front guide wheel unit rated load capacity plus (+) vehicle's front tire/wheel rated load capacity, whichever is lower.
 - o Vehicle's rear G.A.W.R. (gross axle weight rating) or the sum of rear guide wheel unit guide wheel rated load capacity plus (+) vehicle's rear tire/wheel rated load capacity, whichever is lower.
 - o Components rated load capacity.
 - o Tire manufacturer's rated load capacity
 - o Vehicle's wheel rated load capacity
 - o Guide wheel unit rated load capacity (700 lbs (318 kg) maximum per guide wheel)
- Observe and follow all railroad safety rules and regulations.
- Know the positions and functions of all controls before attempting to operate vehicle.
- This guide wheel equipment is designed with your safety in mind. Never disconnect and/or attempt to override safety features.
- Supplied lift handles are designed for operating only properly maintained guide wheel equipment. Do not use the lift handle for any purpose other than that for which it was designed. If lift handle is damaged (bent, broken, etc.), it must not be repaired (straightened, welded, etc.), it must be replaced.

NOTE

To help ensure safe operation of this equipment, keep all safety decals clean and legible. Replace safety decals when necessary with new decals, listed in the Parts Section of this manual.

DESCRIPTION

The RAFNA Railgear can be applied to various standard utility vehicles, cab chassis and pickup trucks. The vehicle's G.V.W.R. (gross vehicle weight rating) and/or G.A.W.R. (gross axle weight rating) must comply with specifications recommended by RAFNA. For information regarding special applications, contact RAFNA, G&B Specialties, Berwick, PA.

The RAFNA Railgear has front and rear railgear units which are manually operated and are mounted onto the vehicle frame. The weight of the units is carried on the vehicle frame, above the springs, when the units are in the "highway" position. Load bearing railgear assemblies guide the vehicle during on track operation.

The RAFNA railgear equipped vehicle uses the vehicle propulsion and braking system for propelling and braking on track.

NOTE

Front - rear and left - right are determined from the vehicle operator's seat

SERIAL NUMBERS

When this bulletin is received, complete the following record from the serial number tag on both the front and rear railgear units. Always provide these factory serial numbers when calling or writing about the units. The serial number tags are located on the frame mounting assembly on both units.

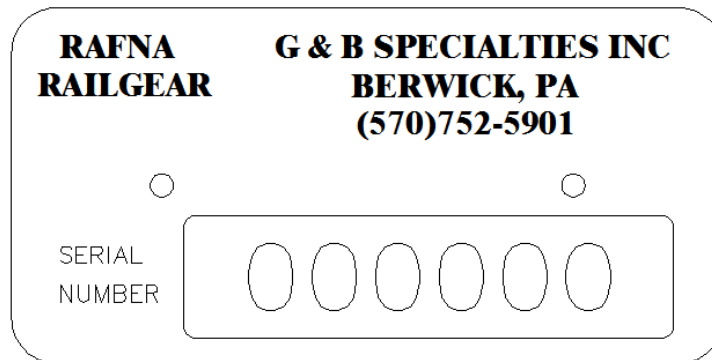

Figure 1-1
Front railgear unit serial number tag

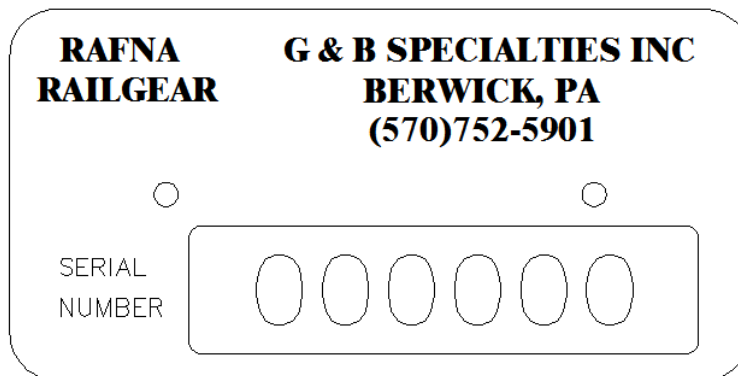

Figure 1-2
Rear railgear unit serial number tag

WEIGHT SPECIFICATIONS

Vehicle

The vehicle's G.V.W.R. (gross vehicle weight rating) and/or G.A.W.R. (gross axle weight rating) must comply with specifications recommended by RAFNA. For information regarding special applications, contact RAFNA, G&B Specialties, Berwick, PA.

Railgear Units

Track Gauge. 56-1/2 in (1435 mm)

Guide Wheels - All Tread Types

- Flange Diameter. 12-1/4 in (311 mm)
- Tread Diameter. 10 in (254 mm)

Weight

- Front Unit. 255 lbs (116 kg)
- Rear Unit. 255 lbs (116 kg)

Recommend Load per Railgear - All Tread Types 350 - 400 lbs (159 - 182 kg)

2.0 INSTALLATION

MOUNTING OF RAILGEAR

The Rafna R-307A railgear utilizes a solid support frame assembly and will need to have holes drilled to mount the railgear to the mounting brackets. The process to do so is detailed below. This will apply to both the front and rear units and the mounting of them.

1. With the mounting brackets already installed on the vehicle (See Front/Rear Mounting Bracket Kit Manuals) , take the outside-to-outside dimension of the mounting brackets. (Figure 2-1, X1 Dimension)
2. Take the overall length dimension of the support frame assembly 53.00". (Figure 2-1, X2 Dimension)
3. Subtract the outside-to-outside dimension of the mounting brackets from the overall length dimension of the support frame assembly, and then divide that by 2.
4. This will give you the dimension of how much the support frame assembly should stick out past the mounting brackets on each side. (Figure 2-1, X3 Dimension)
5. As you can see from Figure 2-1, X3 will be you dimension from the end of the support frame assembly to the outside mounting bracket face. If you subtract 3/16" from this dimension (accounting for half the thickness of the mounting adapter plate (R-30062)), it will give the location where the center of the mounting adapter plate should be.
6. Scribe a line on the support frame assembly at this dimension. Measure to the left and right of the scribe 2" and 1 1/2" from rear edge and center punch for a 13/32" hole to be drilled.
7. Once both ends of the support frame assembly are marked, drill the 13/32" holes completely through the top and bottom of the support frame assembly.
8. The mounting adapter plates can now be installed onto the support frame assembly using the supplied 3/8" hardware found in the R-990KIT-389 hardware kit and shims (R-30065 & R-30066). Brackets should be shimmed if needed evenly on both top and bottom. Make sure all the shavings are cleaned and mount the adapter plates on center with the scribe line to get the most adjustability out of the slots when it comes time to align the gear. (Figure 2-2)
9. The railgear via the mounting adapter plates can now be installed onto the vehicle's mounting brackets using the 1/2" hardware found in the R-990KIT-391/393 hardware kit. (Figure 2-3)
10. The recommended height is 16-1/2" \pm 1/2" (419 mm \pm 12.7 mm) from the top of the rail to the pivot center of the wheel arm. (Figure 2-4) This dimension is to be taking will all 4 rail wheels locked in the road position.

11. Re-adjust only the wheel arm(s) that were initially not within the recommended height once checked. The difference between the measured height and the recommended height is the approximate height that the wheel arms must be adjusted.
12. Figures 2-5 and 2-6 illustrate typical mounting bracket configurations used on the front and rear guide wheel units. Mounting brackets may vary in detail, depending on the vehicle.
13. The adjustments can be made in 1 inch or 1/2 inch increments. Either one or a combination of both can be used to achieve the recommended height. Before removing any bolts, securely block the guide wheel unit.
 - 1 inch (25.4 mm) increments:
 - Remove cap screws in vehicle mounting brackets (1) and relocate in a different set of holes in the mounting bracket (2). Reinstall and re-tighten the cap screws.
 - 1/2 inch (12.7 mm) increments:
 - Remove cap screws in vehicle mounting brackets (1). Remove cap screws from the support frame assembly (3) and adapter bracket (4). Reverse adapter bracket (4) (top to bottom) and reinstall.
14. Once the proper mounting height is achieved, Refer to section 4 for the checking/setting of the wheel weights and finalization of the install.

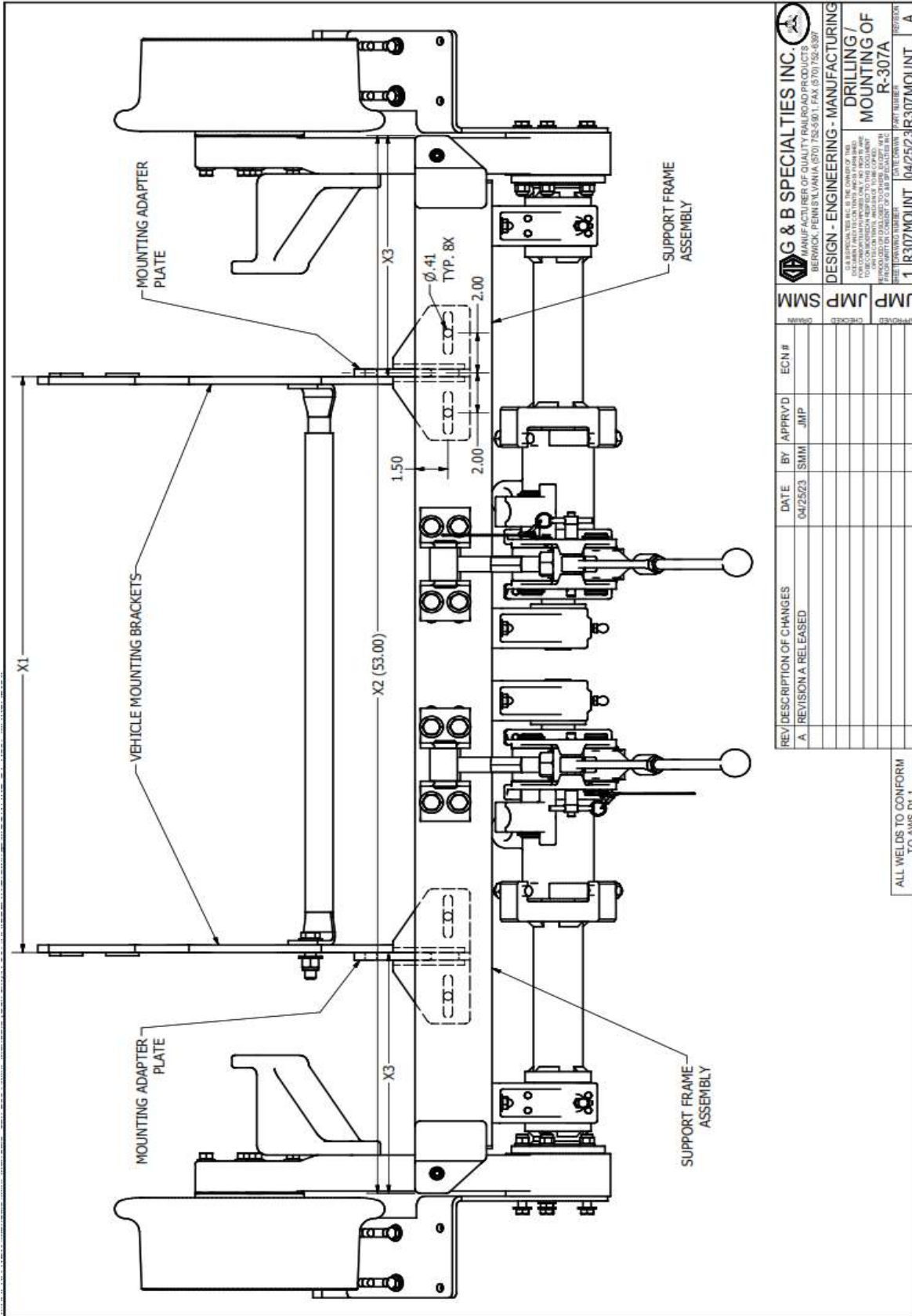
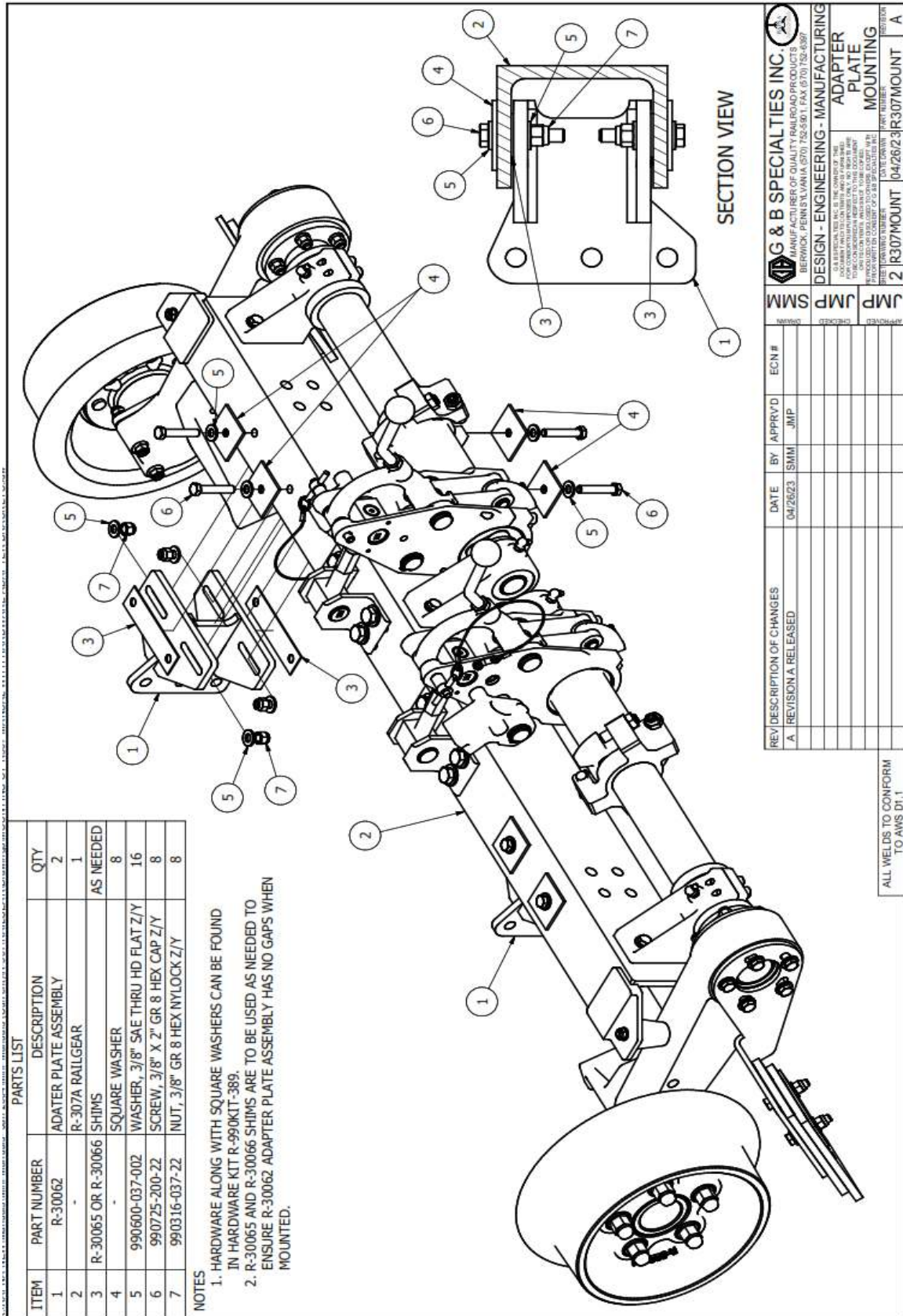

Figure 2-1



PARTS LIST			
ITEM	PART NUMBER	DESCRIPTION	QTY
1	R-30062	ADAPTER PLATE ASSEMBLY	2
2	-	R-307A RAILGEAR	1
3	R-30065 OR R-30066	SHIMS	AS NEEDED
4	-	SQUARE WASHER	8
5	990600-037-002	WASHER, 3/8" SAE THRU HD FLAT Z/Y	16
6	990725-200-22	SCREW, 3/8" X 2" GR 8 HEX CAP Z/Y	8
7	990316-037-22	NUT, 3/8" GR 8 HEX NYLOCK Z/Y	8

NOTES
 1. HARDWARE ALONG WITH SQUARE WASHERS CAN BE FOUND IN HARDWARE KIT R-990KIT-389.
 2. R-30065 AND R-30066 SHIMS ARE TO BE USED AS NEEDED TO ENSURE R-30062 ADAPTER PLATE ASSEMBLY HAS NO GAPS WHEN MOUNTED.

REV	DESCRIPTION OF CHANGES	DATE	BY	APPRVD	ECN #	CHKD	APPROV	REV
A	REVISION A RELEASED	04/26/23	SMM	JMP				

REV	DESCRIPTION OF CHANGES	DATE	BY	APPRVD	ECN #	CHKD	APPROV	REV
2	R307MOUNT	04/26/23	R307MOUNT					A

ALL WELDS TO CONFORM TO AWS D1.1

Figure 2-2

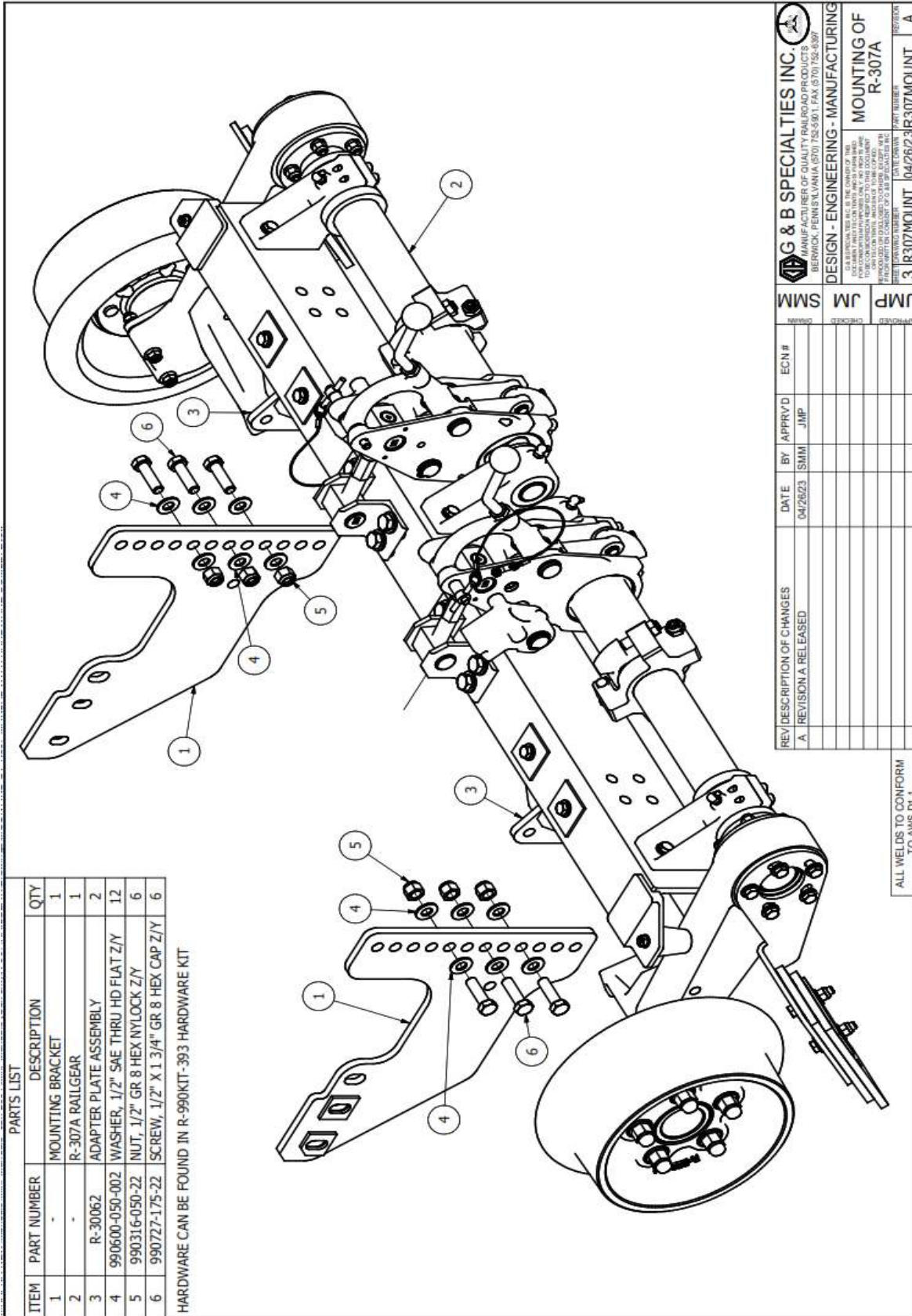

REV/DESCRIPTION OF CHANGES	DATE	BY	APPRVD	ECN#
A REVISION A RELEASED	04/26/23	SMM	JMP	
APPROVED				
DESIGNED				
CHECKED				
DATE DRAWN	04/26/23	PART NUMBER	R307MOUNT	
DATE CHECKED		REVISION	A	

G & B SPECIALTIES INC.
MANUFACTURER OF QUALITY RAILROAD PRODUCTS
BERWICK, PENNSYLVANIA (570) 752-5901 FAX (570) 752-6397

DESIGN - ENGINEERING - MANUFACTURING

MOUNTING OF R-307A

ALL WELDS TO CONFORM TO AWS D.1.

Figure 2-3

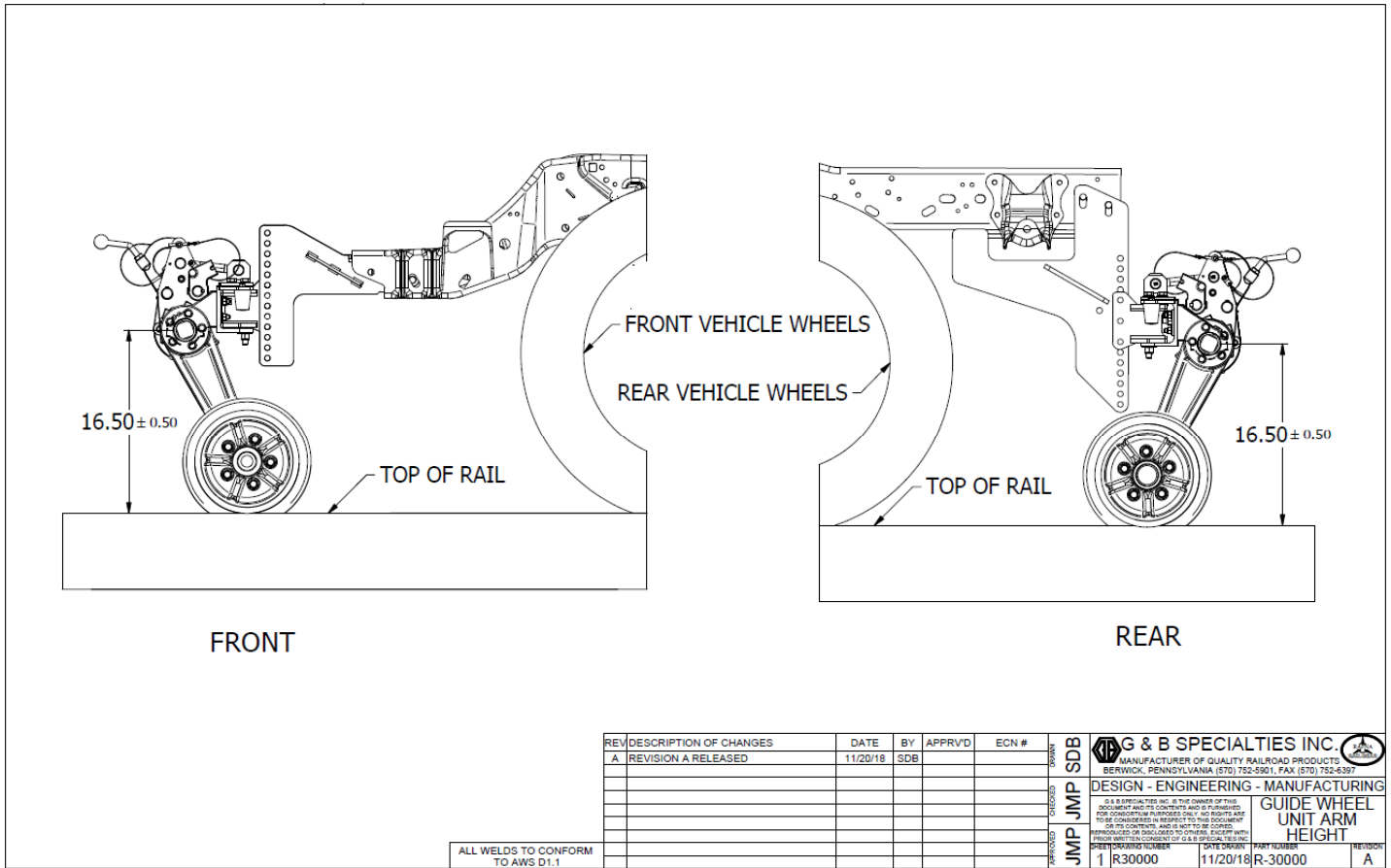

Figure 2-4

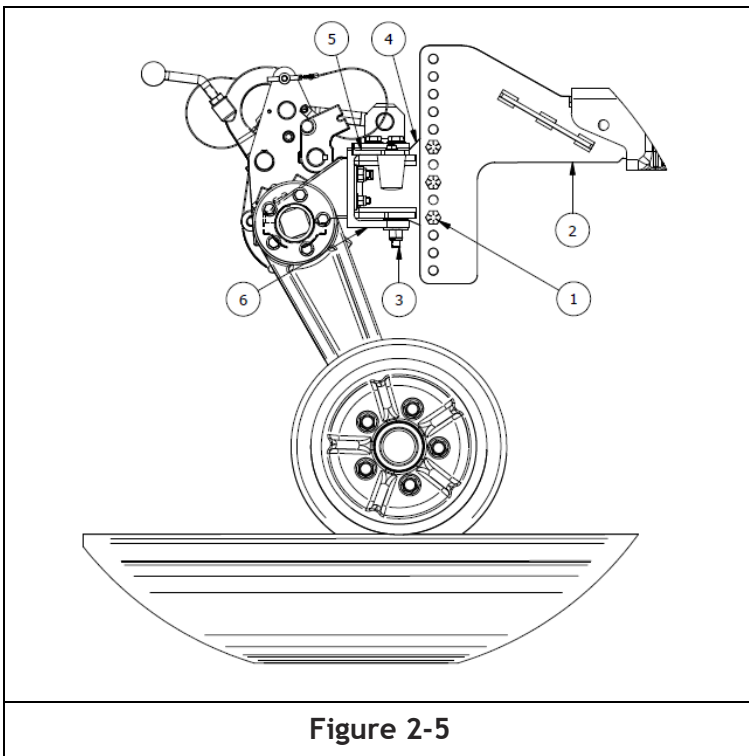

Figure 2-5

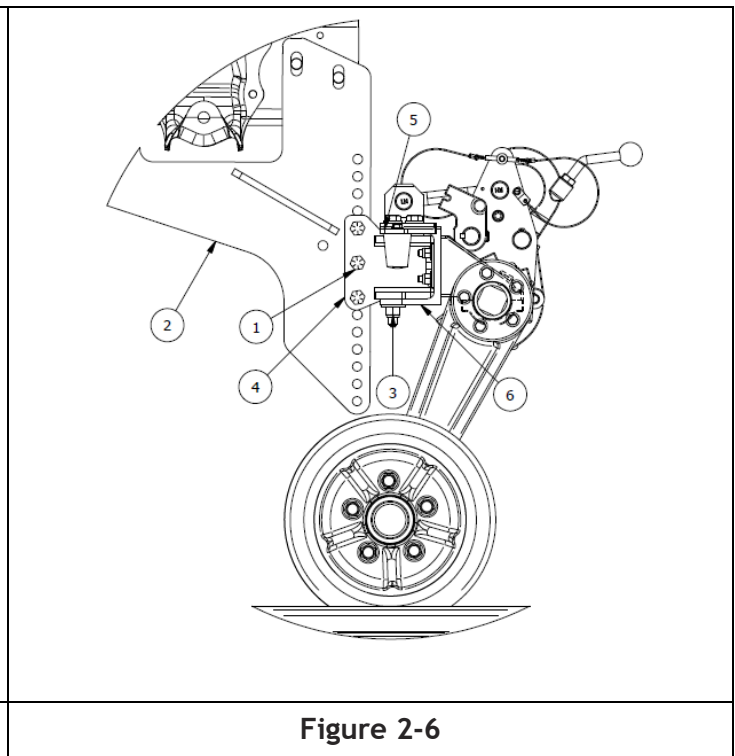

Figure 2-6

3.0 OPERATIONS

PREPARING FOR OPERATION

Vehicle

Be sure the vehicle is in operating condition by checking the following:

- Engine oil level.
- Radiator fluid level.
- Fuel tank level.
- Brakes work properly.
- Parking brake works properly.
- Head, brake and signal lights work properly.
- Tires properly inflated to the manufacturer's recommended maximum pressure printed on the sidewall of the tires, or the wheel manufacturer's recommended maximum pressure stamped on the wheel, whichever is lower.
- Vehicle wheels: Lug nuts / bolts tightened to the proper torque, inspect vehicle wheels, lug bolts and lug nuts for wear or damage. For vehicle wheel, lug bolt and lug nut inspection information refer to the "User's Guide to Wheels and Rims" produced by The Maintenance Council.
- Any other normal maintenance requirements.

Speedometer

When wheel/tire modifications are applied, check and change speedometer drive ratio if necessary. The speedometer drive ratio will influence the operation of the vehicle's anti-lock brake systems, electronically controlled transmission shift timing and speedometer display of the true vehicle speed.

WARNING

Failure to maintain correct speedometer drive ratio could result in severe bodily injury.

Some vehicles require special larger diameter wheels and/or wheel spacers to properly space the vehicle tires for on track operation. Use of these wheel modifications may affect the speedometer drive ratio calibration. The speedometer drive ratio will influence the operation of the vehicle's anti-lock brake systems, electronically controlled transmission shift timing and speedometer display of the true vehicle speed. The vehicle speedometer must be re-calibrated when wheel modifications are applied to the vehicle. See the vehicle manufacturer or dealer for speedometer calibration information.

Railgear Equipment

Be sure the front and rear railgear units are in operating condition by checking the following:

- Overall for damaged or worn parts.
- Proper alignment and guide wheel loads.
- Proper lubrication at recommended operating hourly intervals.

Misalignment Indicators

Before operating a vehicle with newly installed railgear equipment on track, verify that the railgear equipment alignment procedure has been completed. Check and correct alignment promptly if misalignment is indicated.

WARNING

Misalignment of railgear equipment could result in derailment of the vehicle and severe bodily injury.

The following conditions may indicate that minor adjustments to the Railgear equipment alignment are necessary. If any of these conditions occur during operation, perform the Track Test, see Adjustment Section - Vehicle Track Test and/or complete the Alignment Procedure, see Adjustment Section - Railgear Equipment Alignment Procedure.

- a. Excessive flange or tread wear on any of the rail guide wheels.
- b. The vehicle pulls noticeably to the left or right during track operation.
- c. Vibration felt throughout the vehicle at various speeds during track operation.

PLACING VEHICLE ON TRACK

WARNING

Failure to heed the following directions exactly as indicated, could result in damage or derailment of the vehicle and severe bodily injury.

1. Always place vehicle automatic transmission in "park" or manual transmission in "neutral" when manipulating railgear. Always apply the parking brake.
2. Understand equipment operation and be aware of all pinch points before operating or making adjustments to guide wheel equipment.
3. Before propelling the vehicle on the track, make sure:
 - All four guide wheels are lowered, locked in the rail position, and secured with the lock pin.
 - All guide wheel flanges are engaged on the inside of the rail.
 - The front wheels are pointed straight ahead, and the steering wheel lock is engaged.
 - d. The supplied lift handles are designed for operating only properly maintained guide wheel equipment. Do not use the lift handle for any purpose other than that for which it was designed. If the lift handle is damaged (bent, broken, etc.), it must be replaced.

WARNING

Do not attempt to repair (straighten, weld, etc.) a damaged handle, attempting to do so may allow spontaneous failure under load to occur, possibly resulting in injury or damage to property.

5. Observe and follow all railroad safety rules and regulations.
6. If the vehicle is equipped with a strobe light (beacon) and railroad rules and regulations require its use, the strobe light (beacon) must be illuminated when placing the vehicle on track and when operating the vehicle on track.

Lowering Guide Wheels

1. Ensure that highway vehicles are not approaching the grade crossing while placing the vehicle on track. To ensure safety, flag the crossing per railroad rules and regulations.
2. At a road crossing, drive the vehicle about 25 feet (7.6 M) past the track. Back the vehicle onto the rails so that the rear vehicle wheels are centered on rails. It may be necessary to move the vehicle back and forth several times to get the wheels centered on the rail properly.
3. Place automatic transmission in "PARK" or manual transmission in "NEUTRAL". Apply the parking brake.
4. Lower and lock the rear guide wheels first. The rear guide wheels should be lowered first so the vehicle front tires can be maneuvered to align the front guide wheels with the rails.
5. Remove lock pin (1). Button in "T" end of the pin must be pressed in to remove the lock pin. Place the lock pin in a position so that it does not become entangled in the mechanical lock mechanism.
6. Insert the end of hand lever (5) with the long single bend (B) into socket (2). Maintain a firm grip on the hand lever to prevent the guide wheels from dropping suddenly when the mechanical lock is released.
7. Push the locking pawl handle (4) to release the mechanical lock. Use the hand lever (5) to lower the guide wheel to the rail.
8. Remove hand lever (5) from socket (2) and insert the opposite end with short single bend (A) into socket (3). Push down on the hand lever, forcing the guide wheel down until the locking mechanism fully locks, securing the guide wheel in the "rail" position.
9. Insert lock pin (1) to secure the locking pawl (4). Button in "T" end of the pin must be pressed in to insert the lock pin. Remove hand lever (5) from socket (3).
10. Repeat Steps 5 through 9 to lower and lock the other rear guide wheel in the "rail" position.
11. After the rear guide wheels are locked in the "rail" position, move the vehicle so that the vehicle front wheels are centered on the rail. Follow the same procedure to lock the front guide wheels in the "rail" position.

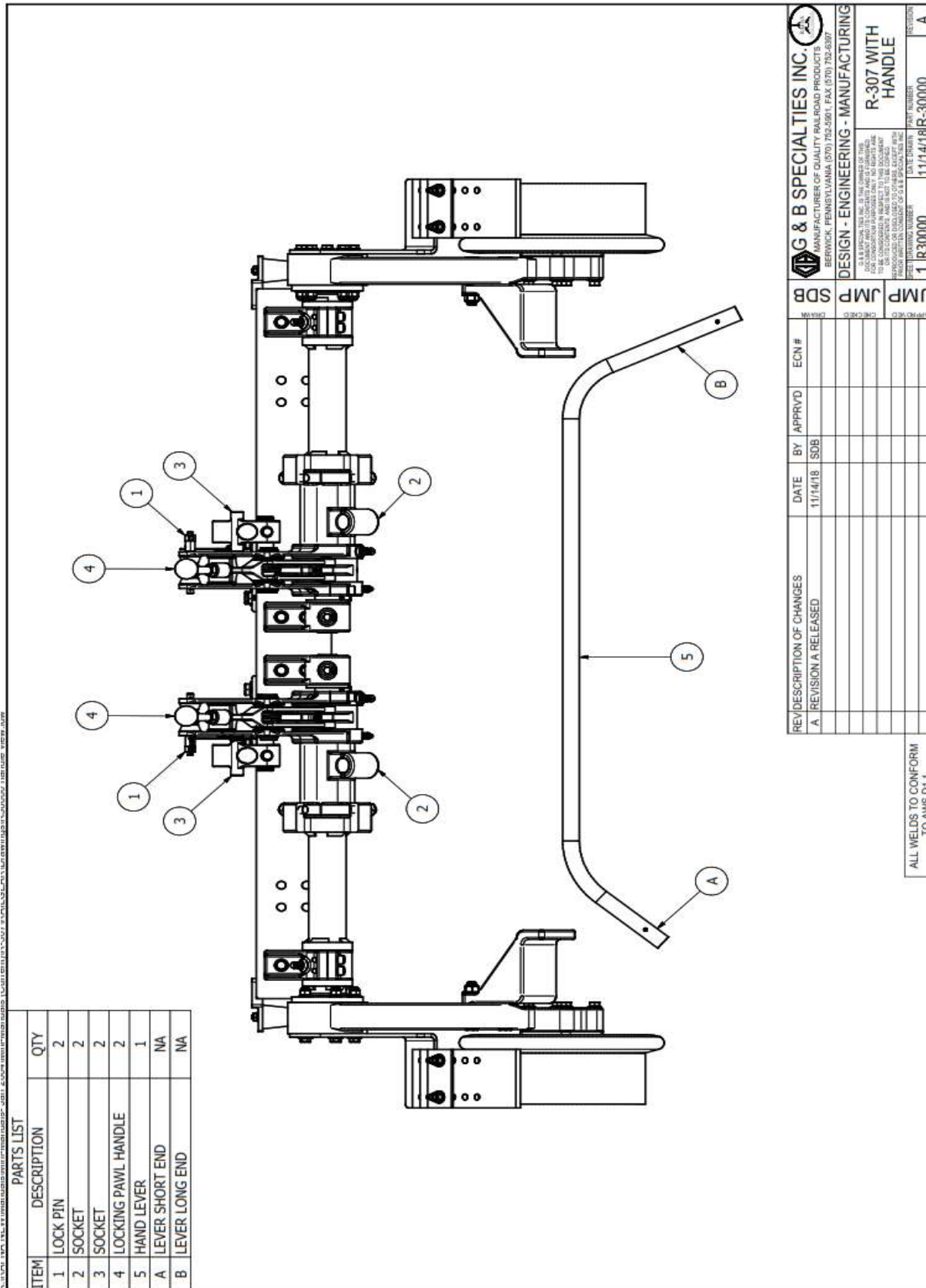

Figure 3-1: Railgear with Hand Lever

INSTALLATION OF STEERING WHEEL LOCK

The following procedure details the steering wheel lock installation. The hardware required for this installation is listed in Table 1.

Table 1: Steering Wheel Lock Kit

S-001050	Steering Wheel Lock	1
S-001040	Steering Wheel Lock Decal	1

1. Ensure the front wheels are pointing straight ahead and the steering wheel is centered before installation.
2. The steering wheel lock consists of one steering wheel lock patch with RAFNA logo and three adhesive back strips.
3. Without removing the protective backing, position one adhesive back strip on top of the steering column cover and another on the steering wheel. The strips should be close enough together so that the patch will cover both when the steering wheel lock is engaged. Ensure that the adhesive back strips do not interfere with any devices, such as the hazard light button on the steering column cover or the air bag cover on the steering wheel. Modify the adhesive back strips as required to clear any obstructions. Mark their locations on the steering column cover and the steering wheel.
4. Without removing the protective backing, position the third adhesive back strip in a convenient location on the dash (so that it does not interfere with the view and/or operation of the vehicle). This adhesive back strip will serve as a holder when the steering wheel lock is disengaged. Mark the location.
5. Scuff the three areas previously marked with medium / fine sand paper. The areas should be free of dust, dirt, and any oily residue. Thoroughly clean the areas with denatured alcohol or a similar nonoil based degreaser that will not react with the plastic. Let dry.
6. Take care when placing the adhesive back strips; once they are applied, they should not be removed. Do not touch the adhesive with your fingers. Removing the adhesive back strips once installed or touching the adhesive may cause poor adhesion.
7. Peel off the protective backing from the adhesive back strips. Firmly press them into place as previously located. Do not disturb the adhesive back strips for 24 to 30 hours to allow the adhesive to fully cure.
8. Store the steering wheel lock patch on the adhesive back strip located on the dash.
9. Stick the steering wheel lock decal in a highly visible spot on the dashboard.

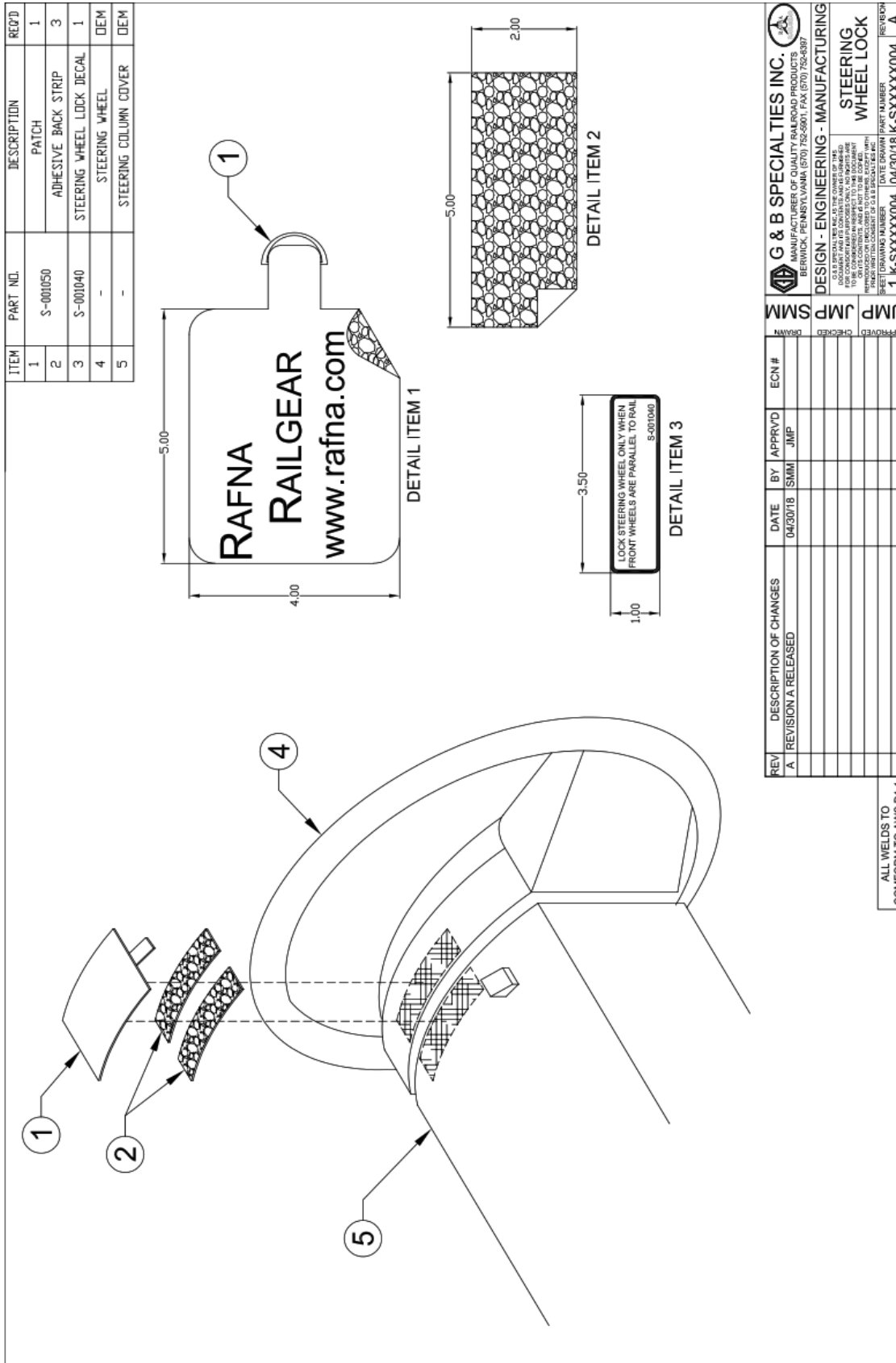

Figure 3-2: Velcro Steering Wheel Lock

Rail Sweeps

NOTE

The guide wheel units may be equipped with rail sweeps. The rail sweeps are positioned ahead of the front guide wheels and behind the rear guide wheels. The rail sweeps clear the rail of debris, lengthening the service life of the guide wheels.

The rail sweeps are attached to the wheel arm and will lower when the guide wheels are lowered to the "rail" position and will raise when the guide wheels are raised to the "highway" position.

Guide Wheel Load on Track

- Improper loading of the guide wheel equipped vehicle can cause derailment of the vehicle.
- Apply vehicle parking brake and stop vehicle engine before checking guide wheel load.
- Never operate the vehicle on the "rail" with one or more of the overload set screws bottomed out.
- Always check the guide wheel load before operating the vehicle on track. Minimum load on any guide wheel must be at least 350 lbs. (159 kg). Maximum load on any guide wheel must not exceed 700 lbs. (318 kg). Never operate the vehicle on track if the load on any guide wheel is not within these ranges.
- Do not use any jack other than the RAFNA wheel weighing jack no. 073527 to check the guide wheel load. Use of any other jack will result in incorrect guide wheel load information.
- Misuse of the wheel weighing jack may cause gauge to explode. Read ANSI b40.1 and apparatus installation / operating instructions before use.
- Do not use the wheel weighing jack to lift the vehicle. Excessive weight may cause the jack to fail.

Checking Guide Wheel Load

1. Lower and lock all guide wheels in the rail position. When the vehicle is at curb weight (with permanent attachments such as: spare tire, tool box less tools, utility box, crane, aerial lift boom, etc.; and without passengers, baggage, load, etc.) there should be 3/8 inch (9.5 mm) clearance between the overload set screw and the stop on the casting. Check the overload set screws on each guide wheel whenever the vehicle is loaded, or additional load is added to the existing vehicle load on "rail". If any of the overload set screws are bottomed out against the stop on the casting, the load must be redistributed or some of the load removed. Never operate the vehicle on "rail" with one or more of the overload set screws bottomed out.
2. Use the wheel weighing jack (RAFNA part no. Co-105) to check the guide wheel load if any of the overload set screws are bottomed out against the stop on the casting and/or to determine the load on the guide wheel. Do not use any other jack then the RAFNA wheel weighing jack no. Co-105 to check the guide wheel load. Use of any other jack will result in incorrect guide wheel load information.
3. See Figure 3-4. Place the wheel weighing jack (CO-105) under the guide wheel arm directly below the wheel spindle. Jack the guide wheel up until the guide wheel just clears the top of the rail. Note the gauge reading. The gauge reading indicates the pounds of load on the guide wheel.

NOTE

An easy way to tell when the guide wheel just clears the top of rail, is to jack the wheel up approximately 1/4" (6.4 mm) above the top of the rail. Place a piece of paper between the rail and the guide wheel. Lower the guide wheel onto the paper. Slowly jack the guide wheel up while applying a steady pulling force on the paper until the paper can be pulled out. Note the gauge reading when the paper can be removed.

4. The recommended guide wheel load is 350 - 400 lbs (159 - 182 kg) at specified guide wheel height. With the vehicle loaded, the maximum guide wheel load is 700 lbs (318 kg). The guide wheel load should be equal (+/- 25 lbs) on both the left and right sides of the unit.
5. If the measured load is less than the minimum guide wheel load of 350 lbs (159 kg) or exceeds the maximum guide wheel load of 700 lbs (318 kg) on any guide wheel, the guide wheel unit must be adjusted, or the vehicle load must be redistributed or some of the load removed. Never operate the vehicle on track if the load on any guide wheel is not within these ranges. See the Adjustments Section - Guide Wheel Equipment Alignment Procedure.

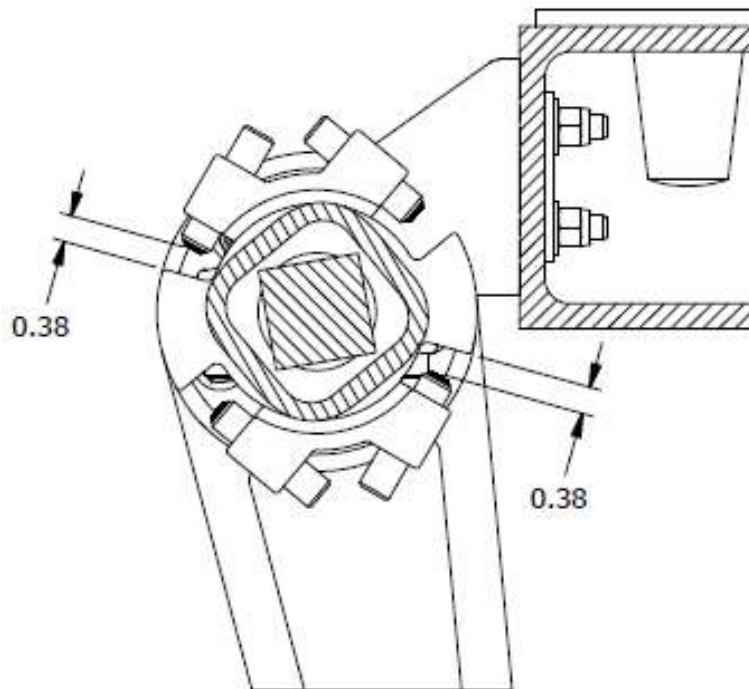

Figure 3-3: Guide Wheel Overload Set Screws

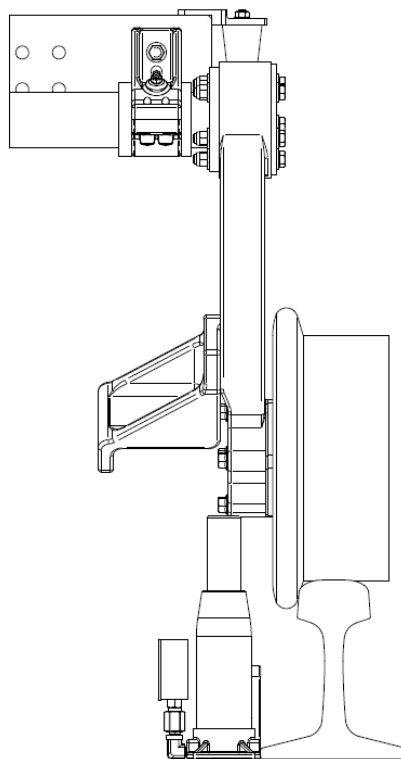

Figure 3-4: Wheel Weight Jack

MOVING ON TRACK

Propelling on Track

WARNING

Failure to comply with the following requirements could result in vehicle derailment and/or severe bodily injury.

- Improper loading of the guide wheel equipped vehicle can cause derailment of the vehicle.
- Always check the guide wheel load before operating the vehicle on track. Minimum load on any guide wheel must be at least 350 lbs (159 kg). Maximum load on any guide wheel must not exceed 700 lbs (318 kg). Never operate the vehicle on track if the load on any guide wheel is not within these ranges.
- Before or when propelling on track:
 - Observe and follow all railroad safety rules and regulations.
 - The operator must look all directions for persons or objects on or adjacent to the track.
 - Do not accelerate suddenly. Traction is reduced on track, spinning vehicle tires could damage them.
 - Do not exceed 45 mph (72 km/h) when operating the vehicle on track. Railroad rules governing speeds should be observed at all times. Reduce speed when propelling the vehicle through switches, crossings, branch lines and any special track works. Operating the vehicle at unsafe speeds could result in derailment of the vehicle.
 - Steering lock must be engaged at all times when operating the vehicle on track.
- If the vehicle is equipped with a strobe light (beacon) and railroad rules and regulations require its use, the strobe light (beacon) must be illuminated when operating the vehicle on track.

NOTE

Vehicles equipped with R-307A RAFNA Railgear use the vehicle propulsion system. Do not accelerate suddenly. Traction is reduced on the track and spinning the vehicle tires could damage them.

Braking on Track

Vehicles equipped with R-307A Railgear use the vehicle brake system for braking on track. Stopping distance may be greater on track than on typical road surfaces. Apply the brakes gradually to avoid sliding the tires.

WARNING

Failure to heed the following warnings could result in bodily injury and/or Property damage.

- Persons who operate the vehicle must be familiar with track and weather conditions that may affect stopping distance. Be alert to these conditions and allow adequate stopping distance.
- Be prepared to brake at all highway crossings. This vehicle will not operate track signal circuits, and oncoming vehicles or pedestrians may not yield the right of way.

Towing Trailer / Equipment with the Vehicle on Track

WARNING

Failure to heed the following requirements could result in severe bodily injury.

- The vehicle used for towing must be rated by vehicle manufacturer for weight of trailer equipment to be towed. Do not exceed vehicle manufacturer's maximum rated towing capacity.
- The towing vehicle must weigh as much or more than trailer / equipment being towed.
- The vehicle used for towing must have an adequate brake system to safely decelerate and stop the towing vehicle and the trailer / equipment being towed.
- Towing a trailer / equipment lengthens stopping distances. Allow adequate distance for stopping. Anticipate stops so you can brake gradually.
- Stopping distance is greater on track than on typical road surfaces. Apply brakes gradually to avoid sliding vehicle tires and guide wheels.
- Tow trailer / equipment at a reasonable speed, 20 mph (32 km/h) maximum, considering track conditions, track grade, weather, visibility, and stopping distance, to assure safe operation. Railroad rules governing speeds and right of way should be observed at all times.
- The trailer / equipment being towed must be in a safe, usable condition to be towed.
- Make sure that the vehicle has:
 - The front and rear guide wheels lowered and locked in the rail position.
 - All front and rear guide wheel flanges engaged on the inside of the rails.
 - The steering wheel lock engaged with the front wheels straight ahead.
- Carefully and thoroughly prepare the vehicle for towing, making sure to use the right towing equipment, and to attach it properly.
- The towing equipment (hitches, tow bars, etc.) Must be attached to the vehicle frame. Do not mount or attach the towing equipment to the guide wheel units.
- The towing equipment (hitches, tow bars, etc.) Must have a rated towing capacity equal to or greater than the weight of trailer / equipment being towed.

- Use a rigid type tow bar with safety locking couplers. Do not use chain, wire rope etc.
- Observe and follow all railroad safety rules and regulations.
- Do not accelerate suddenly. Traction is reduced on track, spinning the vehicle tires could damage them.

Once you have confirmed compliance with the above safety requirements, you may begin your intended towing operation on track. See the below instructions.

1. See your truck/vehicle operator's manual for towing information. Use the vehicle manufacturer's recommendations to determine the maximum weight the towing vehicle can tow. Do not exceed the vehicle manufacturer's maximum rated towing capacity.
2. The towing vehicle must have an adequate brake system to safely decelerate and stop the towing vehicle and the trailer/equipment being towed. The towing vehicle must weigh as much or more than the trailer/equipment being towed.
3. Make sure that the vehicle has:
 - a. The front and rear guide wheels lowered and locked in the rail position.
 - b. All front and rear guide wheel flanges engaged on the inside of the rails.
 - c. The front wheels set straight ahead, and the steering wheel lock is engaged.
4. Make sure the towing vehicle and the trailer / equipment are in good working condition (tires, brakes, lights, etc.) and that current maintenance has been performed on the vehicle and trailer / equipment.
5. The towing equipment (hitches, tow bars, etc.) on the towing vehicle must have a rating equal to or greater than the weight of the trailer / equipment being towed.
6. The towing equipment (hitches, tow bars, etc.) must be attached to the towing vehicle frame. Do not mount or attach the towing equipment to the guide wheel units.
7. Observe and follow all railroad safety rules and regulations.
8. Do not accelerate suddenly. Traction is reduced on track. Spinning the vehicle tires could damage them.
9. Stopping distance is greater on track than on typical road surfaces. Apply the vehicle brakes gradually to avoid sliding the vehicle tires and the guide wheels. Towing trailer / equipment lengthens stopping distances. Allow adequate distance for stopping. Anticipate stops so that you can brake gradually.
10. Tow the trailer / equipment on the track at a reasonable speed, 20 MPH (32 km/h) maximum, considering track conditions, track grade, weather, visibility, and stopping distance to assure safe operation. Railroad rules and regulations governing speed limits and right of way should be observed at all times.
11. Always chock the trailer wheels before unhooking the trailer from the towing vehicle.

Towing a Disabled Vehicle on the Track

WARNING

Failure to heed these precautions could result in bodily injury and/or property damage.

- The towing vehicle / machine must weigh as much or more than the disabled vehicle being towed.
- The vehicle / machine used for towing must have an adequate brake system to safely decelerate and stop the towing vehicle / machine and the disabled vehicle being towed.
- Towing the disabled vehicle lengthens stopping distances. Allow adequate distance for stopping. Anticipate stops so you can brake gradually.
- Tow the disabled vehicle at a reasonable speed, 10 mph (16 km/h) maximum, considering track conditions, track grade, weather, visibility, and stopping distance, to assure safe operation. Railroad rules governing speed limits and right of way should be observed at all times.
- Stopping distance is greater on track than on typical road surfaces. Apply brakes gradually to avoid sliding the towing vehicle / machine wheels.
- Make sure that the disabled vehicle has:
 - The front and rear guidewheel units lowered and locked in the rail position.
 - All front and rear guide wheel flanges engaged on the inside of the rails.
 - The steering wheel lock engaged with the front wheels straight ahead.
- The tow bar must be attached to disabled vehicle frame. Do not mount or attach the tow bar to the disabled vehicle guide wheel units.
- The tow bar must have a rated towing capacity equal to or greater than weight of the disabled vehicle being towed.
- Use a rigid type tow bar with safety locking couplers. Do not use chain, wire rope etc.
- Observe and follow all railroad safety rules and regulations.
- Do not accelerate suddenly. Traction is reduced on track, spinning the towing vehicle/machine wheels could damage them.
- Tow the disabled vehicle to the nearest road crossing and remove it from the track.

Once you have confirmed compliance with the above safety requirements, you may begin your intended towing operation on track. See the below instructions.

1. See your vehicle operator's manual for towing information.
2. The towing vehicle / machine must have an adequate brake system to safely decelerate and stop the towing vehicle / machine and the disabled vehicle being towed. The towing vehicle / machine must weigh as much or more than the disabled vehicle towed.
3. Make sure that the disabled vehicle has:
 - a. The front and rear guide wheel units lowered and locked in the rail position.
 - b. All front and rear guide wheel flanges engaged on the inside of the rails.
 - c. The front wheels are set straight ahead, and the steering wheel lock is engaged.
4. Make sure the towing vehicle / machine is in good working condition (tires, brakes, lights, etc.) and that current maintenance has been performed on the vehicle / machine.
5. The towing equipment (hitches, tow bars, etc.) on the towing vehicle / machine must have a rating equal to or greater than the weight of the disabled vehicle being towed.
6. The tow bar must be mounted or attached to the disabled vehicle's frame. Do not mount or attach the tow bar to the guide wheel units. Use a rigid type tow bar with safety locking couplers.
7. Observe and follow all railroad safety rules and regulations.
8. Do not accelerate suddenly. Traction is reduced on track. Spinning the towing vehicle tires / machine wheels could damage them.
9. Stopping distance is greater on track than on typical road surfaces. Apply the towing vehicle / machine brakes gradually to avoid sliding the vehicle tires / machine wheels. Towing disabled vehicle lengthens stopping distances. Allow adequate distance for stopping. Anticipate stops so that you can brake gradually.
10. Tow the disabled vehicle on the track at a reasonable speed, 10 MPH (16 km/h) maximum, considering track conditions, track grade, weather, visibility, and stopping distance to assure safe operation. Railroad rules and regulations governing speed limits and right of way should be observed at all times.
11. Tow the disabled vehicle to the nearest road crossing and remove the vehicle from the track.

REMOVING VEHICLE FROM TRACK

1. Place vehicle automatic transmission in "park" or manual transmission in "neutral". Apply the parking brake.
2. Understand equipment operation and be aware of all pinch points before operating or adjusting guide wheel equipment.
3. Before propelling the vehicle off track, make sure:
 - All four guide wheels are raised, locked in the highway position, and secured with the lock pin.
 - The steering wheel lock is disengaged.

WARNING

Failure to heed the following precautions could result in severe bodily injury.

- The supplied lift handles are designed for operating only properly maintained guide wheel equipment. Do not use the lift handle for any purpose other than that for which it was designed. If the lift handle is damaged (bent, broken, etc.), it must not be repaired (straightened, welded, etc.), it must be replaced.
- Observe and follow all railroad safety rules and regulations.
- If the vehicle is equipped with a strobe light (beacon) and railroad rules and regulations require its use, the strobe light (beacon) must be illuminated when operating the vehicle on track and when removing vehicle from track.

Raising Guide Wheels

WARNING

Failure to follow the following instructions correctly could result in bodily injury and/or property damage.

1. Ensure that highway vehicles are not approaching the grade crossing while removing vehicle from track. To ensure safety, flag the crossing per railroad rules and regulations.
2. Approach a road crossing and stop with the vehicle front wheels on the crossing.
3. Place automatic transmission in "PARK" or manual transmission in "NEUTRAL". Apply the parking brake.
4. Raise the front guide wheels first. Then the rear guide wheels.
5. Remove lock pin (1). Button in "T" end of the pin must be pressed in to remove the pin. Place the lock pin in a location so that it does not become entangled in lock.
6. Insert the end of the hand lever (5) with short single bend (A) into socket (3). Push down to remove pressure from the locking pawl handle.
7. Push the locking pawl handle (4) to release the mechanical lock. Raise hand lever (5) to raise the guide wheel until it rests on the rail.
8. Remove the hand lever (5) from socket (3) and insert opposite end with long single bend (B) into socket (2). Push down on the hand lever, forcing the guide wheel up until the locking mechanism fully locks, securing the guide wheel in the "highway" position.
9. Insert lock pin (1) to secure the locking pawl (4). Button in "T" end of the pin must be pressed in to insert the lock pin. Remove hand lever (5) from socket (2).
10. Repeat Steps 5 through 9 to raise the other front guide wheel to the "highway" position.
11. After the front guide wheels are locked in the "highway" position, follow the same procedure to raise and lock the rear guide wheels in the "highway" position.

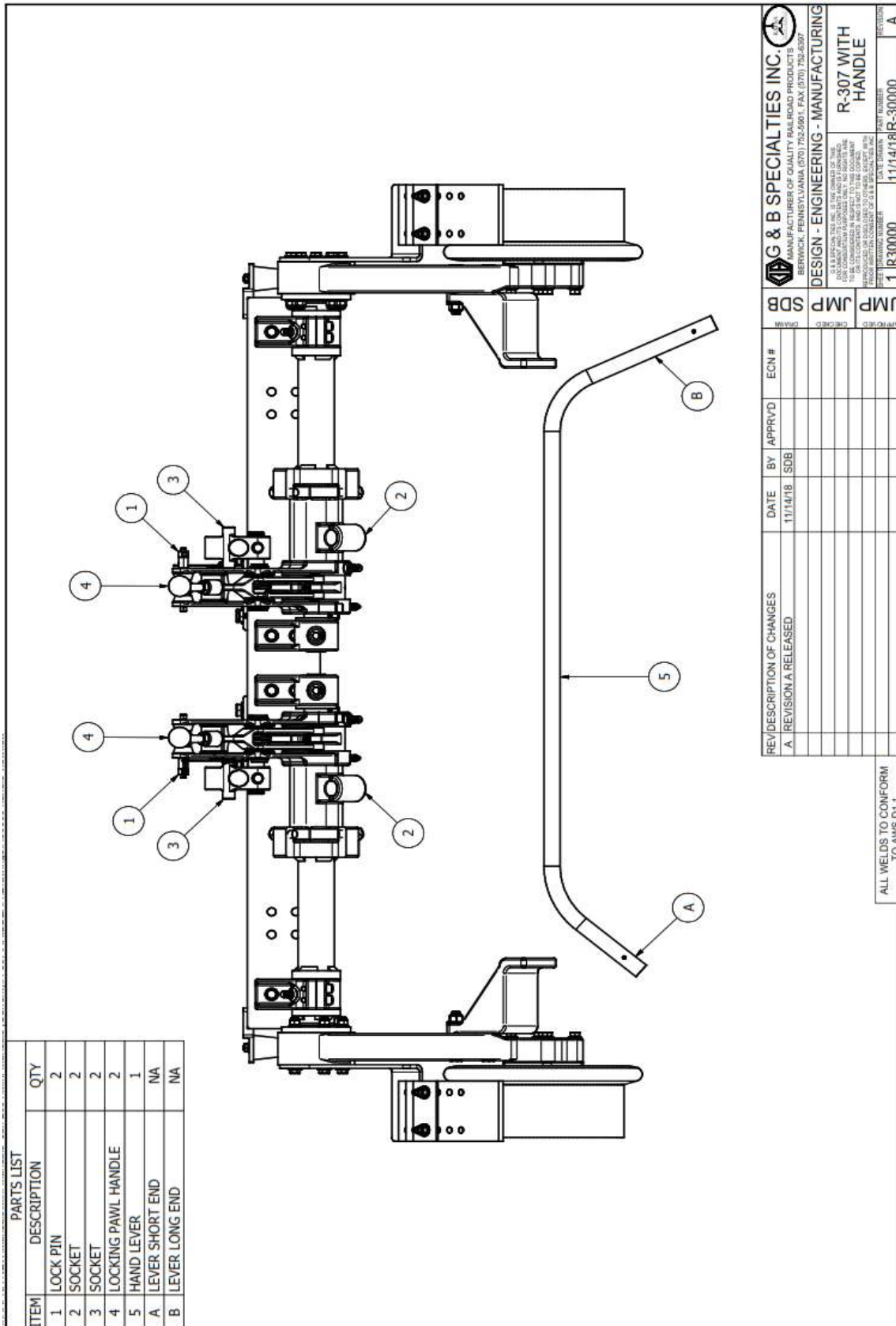

Figure 3-5: Railgear with Hand Lever

HIGHWAY OPERATION

This multipurpose vehicle has special designs and equipment features for off-road use. It handles differently from an ordinary passenger car in driving conditions that may occur on streets, highways and off-road. Weight and location of available payload may also affect the handling of this vehicle. Drive with care and wear safety belts at all times. Read vehicle owner's manual for additional precautions.

Towing Trailer / Equipment with the Vehicle on the Road

- The vehicle used for towing must be rated by the vehicle manufacturer for weight of the trailer / equipment to be towed. Do not exceed the vehicle manufacturer's maximum rated towing capacity.
- The vehicle used for towing must have an adequate brake system to safely decelerate and stop the towing vehicle and trailer / equipment being towed.
- Towing trailer / equipment lengthens stopping distances. Allow adequate distance for stopping. Anticipate stops so you can brake gradually.
- Tow trailer / equipment at a reasonable speed considering road conditions, road grade, weather, visibility and stopping distance to assure safe operation. Posted speed limits should be observed at all times.
- The trailer / equipment being towed must be in a safe, usable condition to be towed.
- Make sure that the vehicle has:
 - The front and rear guide wheel units raised and locked in the highway position.
 - The steering wheel lock disengaged.

WARNING

Failure to heed the following precautions could result in severe bodily injury.

- This multipurpose vehicle has special designs and equipment features for off-road use. It handles differently from an ordinary passenger car in driving conditions that may occur on streets, highways and off-road. Weight and location of available payload may also affect the handling of this vehicle. Drive with care and wear safety belts at all times. Read vehicle owner's manual for additional precautions.
- Observe and follow all federal, state and local driving rules and regulations.
- State laws may require towing vehicle and trailer / equipment being towed to be equipped with special safety equipment (mirrors on both sides of towing vehicle, trailer brakes, trailer lights, etc.).

- Carefully and thoroughly prepare your vehicle for towing, making sure to use the right towing equipment and to attach it properly.
- The towing equipment (hitches, tow bars, etc.) Must be attached to the vehicle frame. Do not mount or attach towing equipment to the guide wheel units.
- The towing equipment (hitch, tow bar, etc.) Must have a rated towing capacity equal to or greater than weight of the trailer / equipment being towed.

Once you have confirmed your vehicles meets the above safety requirements, you may proceed with towing operation.

1. See your vehicle operator's manual for towing information. Use the vehicle manufacturer's recommendations to determine the maximum weight the towing vehicle can tow. Do not exceed the vehicle manufacturer's maximum rated towing capacity.
2. The towing vehicle must have an adequate brake system to safely decelerate and stop the towing vehicle and the trailer/equipment being towed. Towing trailer/equipment lengthens stopping distances. Allow adequate distance for stopping. Anticipate stops so that you can brake gradually.
3. Make sure that the vehicle has:
 - a. The front and rear guide wheel units raised and locked in the highway position.
 - b. The steering wheel lock disengaged.
4. Make sure the towing vehicle and the trailer / equipment are in good working condition (tires, brakes, lights, etc.) and that current maintenance has been performed on the vehicle and trailer / equipment.
5. The towing equipment (hitches, tow bars, etc.) on the towing vehicle must have a rating equal to or greater than the weight of the trailer / equipment being towed.
6. The towing equipment (hitches, tow bars, etc.) must be attached to the towing vehicle frame. Do not mount or attach the towing equipment to the guide wheel units.
7. Observe and follow all federal, state and local driving rules, regulations and laws.
8. State laws may require the towing vehicle and/or the trailer / equipment being towed to be equipped with special safety equipment (mirrors on both sides of the towing vehicle, trailer brakes, trailer lights, etc.).
9. Tow the trailer / equipment on the road at a reasonable speed considering road conditions, road grade, weather, visibility and stopping distance to assure safe operation. Always observe posted speed limits.
10. Always chock the trailer wheels before unhooking the trailer from the towing vehicle.

WARNING

Failure to heed the following directions correctly could result in severe bodily injury.

- Tow the disabled vehicle per the vehicle manufacturer's towing specifications listed in your vehicle's operator's manual.
- The vehicle used for towing must have an adequate brake system to safely decelerate and stop towing vehicle and disabled vehicle being towed.
- Tow the disabled vehicle at a reasonable speed considering road conditions, road grade, weather, visibility and stopping distance to assure safe operation. Posted speed limits should be observed at all times.
- Make sure the disabled vehicle has:
 - The front and rear guide wheel units raised and locked in the o Highway position.
 - The steering wheel lock disengaged.
- Towing equipment (tow truck, tow bars, etc.) Must be attached to the disabled vehicle frame. Do not mount or attach towing equipment to the guide wheel units.
- The towing equipment (tow truck, tow bars, etc.) Must have a rated towing capacity equal to or greater than weight of the disabled vehicle being towed.
- Observe and follow all federal, state and local driving rules and regulations.
- State laws may require towing vehicle and disabled vehicle to be equipped with special safety equipment (lights, etc.).

Once you have confirmed your vehicles meets the above safety requirements, you may proceed with towing operation.

1. See your vehicle operator's manual for towing information.
2. The towing vehicle must have an adequate brake system to safely decelerate and stop the towing vehicle and the disabled vehicle being towed.
3. Make sure that the disabled vehicle has: a. The front and rear guide wheel units raised and locked in the highway position. b. The steering wheel lock is disengaged.
4. Make sure the towing vehicle is in good working condition (tires, brakes, lights, etc.) and that current maintenance has been performed on the vehicle.
5. The towing equipment (tow truck, tow bars, etc.) on the towing vehicle must have a rating equal to or greater than the weight of the disabled vehicle being towed.
6. The towing equipment (tow truck, tow bars, etc.) must be mounted or attached to the disabled vehicle frame. Do not mount or attach the towing equipment to the guide wheel units.

7. Observe and follow all federal, state and local driving rules, regulations and laws.
8. State laws may require the towing vehicle and the disabled vehicle being towed to be equipped with special safety equipment (lights, etc.).
9. Tow the disabled vehicle on the road at a reasonable speed considering road conditions, road grade, weather, visibility and stopping distance to assure safe operation. Always observe posted speed limits.

4.0 RAILGEAR ALIGNMENT PROCEDURE

GUIDE WHEEL EQUIPMENT ALIGNMENT PROCEDURE

- Before performing any adjustments to the guide wheel units or vehicle, always place the automatic transmission in "park" or the manual transmission in "neutral". Apply parking brake.
- Understand equipment operation and be aware of all pinch points before operating or adjusting the guide wheel equipment.

WARNING

Failure to heed these precautions could result in severe bodily injury.

The Guide Wheel Alignment Procedure must be completed when the guide wheel equipment is applied to the vehicle, or when any of the misalignment indicators occur. See Operation Section -Misalignment Indicators.

Vehicle Check

1. The vehicle must be at curb weight with permanent attachments: spare tire, toolbox without tools, utility box, crane, aerial lift boom, etc. and without: passengers, baggage, load, etc.
2. Weigh the entire vehicle and record this weight. Weigh both the front and rear axles of the vehicle separately and record these weights. The weight of the vehicle should not exceed the GVWR (Gross Vehicle Weight Rating) and the weight on the front and rear axles should not exceed their respective GAWR (Gross Axle Weight Rating).
3. Permanent attachments to the vehicle such as a tool box, utility box, crane aerial lift boom, etc. which could cause uneven loading on the guide wheels should be compensated for by adjusting the vehicle suspension by adding leaf springs, coil springs, torsion bars, etc.
4. Tires must be inflated to the lower of the tire manufacturer's recommended maximum pressure printed on the sidewalls of the tires or the wheel manufacturer's recommended maximum pressure stamped on the wheel.
5. Visually inspect the entire vehicle, especially the guide wheel equipment for loose or missing bolts and bent or damaged components. Tighten, repair or replace as necessary.
6. Verify that the vehicle that the guide wheel equipment is being mounted on is equipped correctly (springs, tires, wheels, etc.).
7. Check the following measurements on the vehicle that the guide wheel equipment is to be mounted on before applying the guide wheel equipment to the vehicle.
 - a. Frame must be square. Diagonal measurements should be equal within 1/8 inch (3.2 mm).
 - b. Wheelbase (as measured on each side) must be equal within 1/16 inch (1.8 mm).
 - c. Vehicle axles must be square with the frame within 1/64 inch per foot (.4 mm per 305 mm). RAFNA, G&B Specialties recommends that this be checked by a reputable alignment shop.
8. Mount the railgear to the vehicle.

NOTE

The applicator of the Railgear must make sure the application drawings remain with the vehicle for further reference. If the application drawings are not with the vehicle, contact G&B Specialties, Berwick, PA. to obtain these drawings.

9. After mounting the guide wheel equipment, have a four-point alignment completed on the vehicle including checking the caster, camber, toe-in on the front wheels and thrust angle of the rear axle. The thrust angle of the rear axle should be set as close to zero as possible. If necessary, adjust to vehicle manufacturers' recommendations.
10. Have the headlight aim checked and adjusted, if necessary.

On Track Railgear Check

1. Place the vehicle on straight, level, tangent track or on an alignment rack constructed for guide wheel equipment alignment. If track or an alignment rack is not available, use 4 x 6 inch lumber, on a level floor, to simulate track. Space the lumber so it measures 57-1/2 inches between the inside edges. Using 4 x 6 inch lumber will allow the wheel weighing jack to fit underneath the wheel arm to weigh the guide wheel load when the guide wheels are in the "rail" position.
2. Place the automatic transmission in "Park" or manual transmission in "Neutral". Apply the parking brake. Lower and lock all four guide wheels in the "rail" position. See Operation Section -Placing Vehicle On Track.
3. Set the vehicle wheels straight ahead. Secure the steering wheel using the steering lock.

Guide Wheel Unit Back Flange Gauge

Measure the back-flange gauge of both the front and rear guide wheel units. Measure from the back of the left wheel flange, directly below the center line of the wheel spindle, to the same point on the right wheel flange. Back flange gauge must be 53-3/8 - 53-1/2 inches (1356 - 1359 mm) for both the front and rear guide wheel units. If not, see Adjustment below.

Adjustment

1. Unlock both front and/or both rear guide wheels from the "rail" position. Let the guide wheels rest on the rail.
2. Loosen the inner (1) and outer (2) pivot bearings and trunnion nut bracket cap screws (3). Shift one or both guide wheel assemblies. Re-tighten the cap screws.
3. Lock all guide wheels in the "rail" position. Recheck the guide wheel unit back flange gauge.
4. Repeat the procedure until the guide wheel unit back flange gauge is correct.
5. Always check the guide wheel back flange gauge after performing any guide wheel alignment procedures to ensure the back-flange gauge is within the allowable limits.

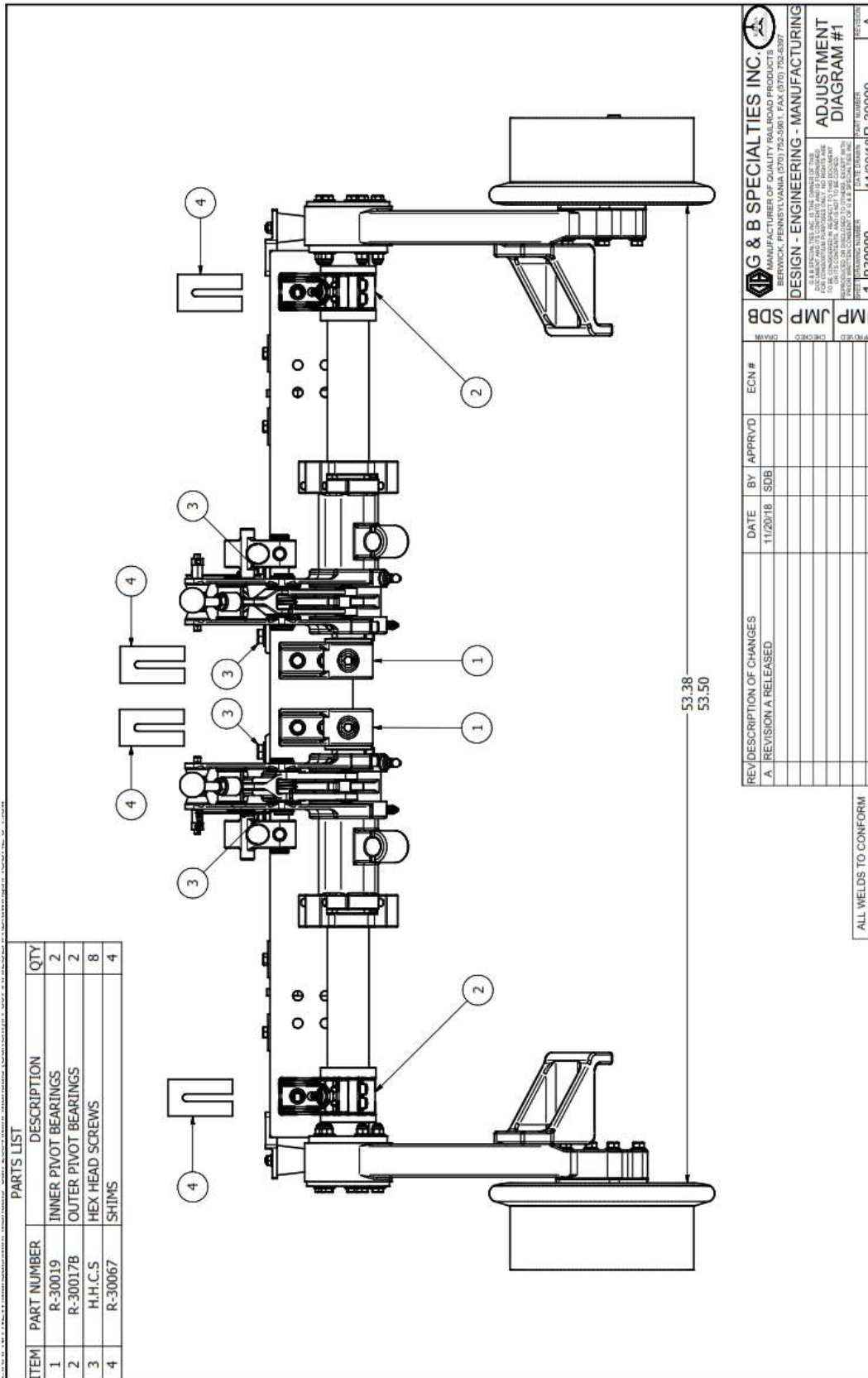

Figure 4-1: Guide Wheel Unit Back Flange Gauge

 G & B SPECIALTIES INC. MANUFACTURER OF QUALITY RAILROAD PRODUCTS BERWICK, PENNSYLVANIA (570) 752-5901 FAX (570) 752-6397		DESIGN - ENGINEERING - MANUFACTURING <small> G & B SPECIALTIES INC. IS THE OWNER OF THE PATENT RIGHTS IN THE DESIGN AND CONSTRUCTION OF THE GUIDE WHEEL UNIT BACK FLANGE GAUGE FOR USE ON ALL RAILROADS. NO PARTS OF THIS DESIGN OR CONSTRUCTION ARE TO BE REPRODUCED WITHOUT THE WRITTEN CONSENT OF G & B SPECIALTIES INC. </small>
REVISIONS OF CHANGES A. REVISION A RELEASED	DATE BY APPROVD 11/20/18 SDB	ECN # APPROVED JMP JDB JMP JDB JMP JDB
PART NUMBER 112018R-30000 PART NUMBER 112018R-30000		PART NUMBER 112018R-30000 REVISION A

ALL WELDS TO CONFORM TO AWS D1.1

Guide Wheel Arm Vertical Height

1. Figure 4-2 illustrates a side view of a typical R-307A Railgear application. Railgear unit mounts may vary in detail, depending on the vehicle.
2. Lower and lock all four guide wheels in the "rail" position. Measure the vertical distance from the top of the rail to the pivot center of the wheel arm on all guide wheels.
3. With the vehicle at curb weight, the recommended height is 16-1/2" ±1/2" (419 mm ±12.7 mm) at specified guide wheel load. If the vertical height is not correct on any of the wheel arms, see Adjustment.

NOTE

For maximum load carrying capacity, set both rear wheel arms to the upper recommended height limit.

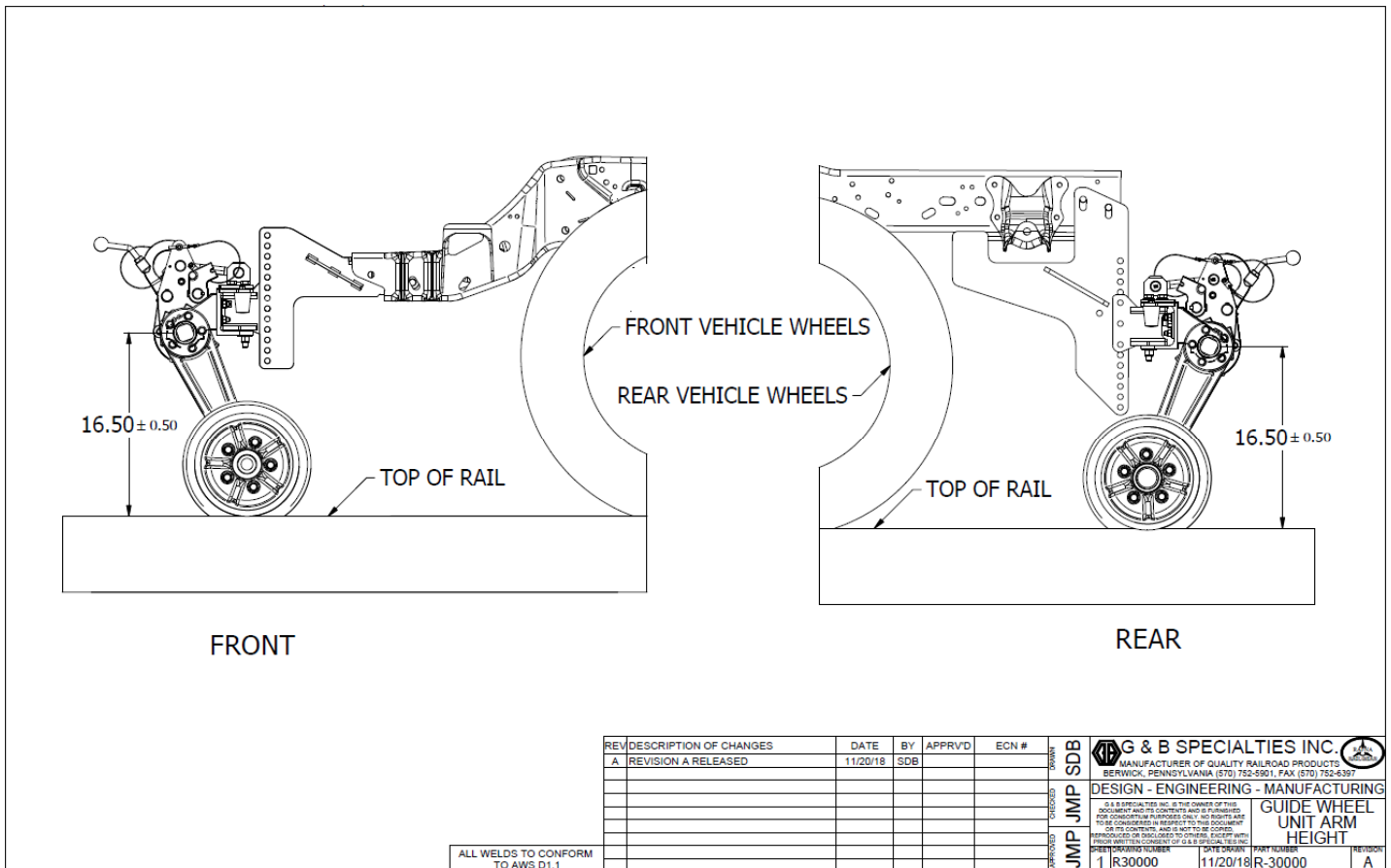

Figure 4-2: Guide Wheel Unit Wheel Arm Vertical Height

Vertical Adjustment

1. Unlock both front and/or both rear guide wheels from the "rail" position. Let the guide wheels rest on the rails.
2. Re-adjust only the wheel arm(s) that were initially not within the recommended height. The difference between the measured height and the recommended height is the approximate height that the wheel arms must be adjusted.
3. Figures 4-3 and 4-4 illustrate typical mounting bracket configurations used on the front and rear guide wheel units. Mounting brackets may vary in detail, depending on the vehicle.
4. The adjustments can be made in 1 inch or 1/2 inch increments. Either one or a combination of both can be used to achieve the recommended height. Before removing any bolts, securely block the guide wheel unit.
 - 1 inch (25.4 mm) increments:
 - Remove cap screws (1) and relocate in a different set of holes in the mounting bracket (2). Reinstall and re-tighten the cap screws.
 - 1/2 inch (12.7 mm) increments:
 - Remove cap screws (1). Remove cap screws (3) and adapter bracket (4). Reverse adapter bracket (4) (top to bottom) and reinstall.

NOTE

It is acceptable to reverse only one of the adapter brackets (4) to compensate for differences in the vehicle frame but the adapter brackets (4) must be mounted in the same holes, left and right, on mounting brackets (2).

As an example: if the top bolt of the left adapter bracket (4) is located five holes down from the top of mounting bracket (2), the top bolt of the right adapter bracket (4) must also be located five holes down from the top of mounting bracket (2).

5. Be sure to reinstall the 1/32" and 1/16" shims (5) on the top or bottom of the adapter bracket (4). The adapter bracket (4) must fit snug inside of the cross channel (6). The shims are used as required. Reinstall and re-tighten the cap screws.
6. Lock all guide wheels in the "rail" position. Recheck the vertical height on all wheel arms.

NOTE

Any wheel arm height adjustment made may change the guide wheel load. Recheck the guide wheel load. Wheel arm vertical height and guide wheel load must both be attained at the same time within the specified height dimensions and load limits. If the wheel arm vertical height and guide wheel load cannot be attained at the same time within the specified height dimensions and load limits, the rubber cords may need to be replaced.

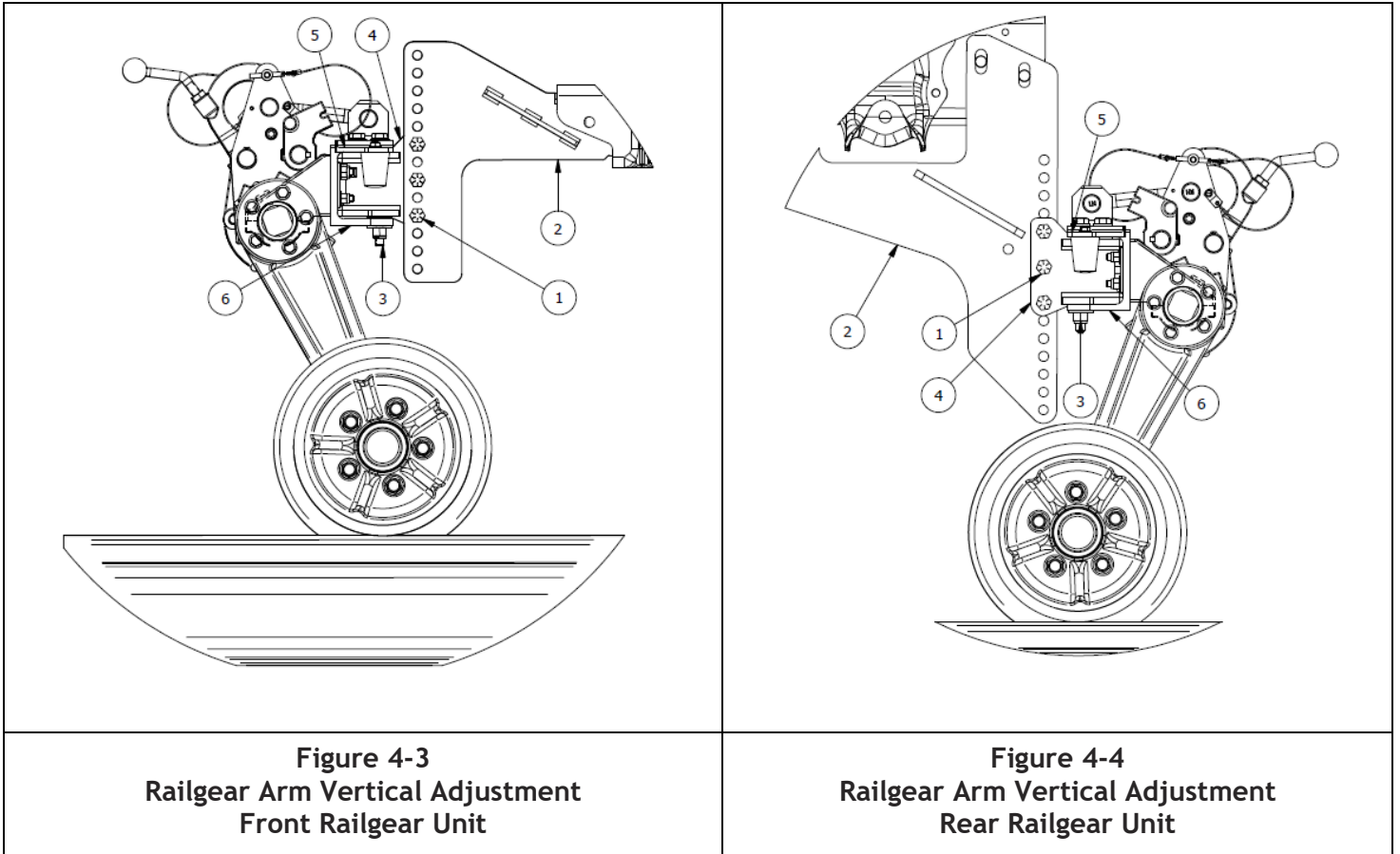

Guide Wheel Load

- Do not use any other jack than the RAFNA wheel weighing jack no. Co-105 to check the guide wheel load. Use of any other jack will result in incorrect guide wheel load information.
- Do not use the wheel weighing jack to lift the vehicle. Excessive weight may cause jack to fail. Misuse of wheel weighing jack may cause gauge to explode. Read ANSI b40.1 and apparatus installation / operating instructions before use.

WARNING

Failure to heed these precautions could result in bodily injury and/or property damage

1. Lower and lock all guide wheels in the "rail" position. Do not use any other jack than the RAFNA wheel weighing jack no. CO-105 to check the guide wheel load. Use of any other jack will result in incorrect guide wheel load information.

2. Place the wheel weighing jack (part no. CO-105) under the guide wheel arm directly below the wheel spindle, see Figure 4-5. Jack the guide wheel up until the guide wheel just clears the top of the rail. Note the gauge reading. The gauge reading indicates the pounds of load on the guide wheel.

NOTE

An easy way to tell when the guide wheel just clears the top of rail is to jack the wheel up approximately 1/4" (6.4 mm) above the top of the rail. Place a piece of paper between the rail and the guide wheel. Lower the guide wheel onto the paper. Slowly jack the guide wheel up while applying a steady pulling force on the paper until the paper can be pulled out. Note the gauge reading when the paper can be removed.

- With the vehicle at curb weight, the recommended guide wheel load is 350 - 400 lbs (159 - 182 kg) at specified guide wheel height
- With the vehicle loaded, the maximum guide wheel load is 700 lbs (318 kg). If the load is not correct on any guide wheel, see "Wheel Load Adjustment" below.

NOTE

For maximum load carrying capacity, set both rear guide wheels to the lower recommended load limit.

Wheel Load Adjustment

1. Unlock both front and/or rear guide wheels from the "rail" position. Let the guide wheels rest on the rails.
2. Figure 4-6 illustrates the load adjustment stud on the front and rear units. Each guide wheel is adjusted independently of the other.
3. Loosen the jam nut (1) using the provided wrench.
 - To Increase the Load: Turn the adjusting stud (2) clockwise, shortening the distance between the trunnion nuts (3).
 - To Decrease the Load: Turn the adjusting stud (2) counter-clockwise, lengthening the distance between the trunnion nuts (3).
4. Lock all guide wheels in the "rail" position. Recheck the guide wheel load on all guide wheels. When the load indicated is within the recommended weight, tighten jam nut (1) securely.
5. If the recommended guide wheel load cannot be achieved by turning the adjusting stud, the guide wheel arm vertical height must be adjusted lower.

NOTE

Any guide wheel load adjustment made may change the railgear arm vertical height. Recheck the railgear arm vertical height. Guide wheel load and guide wheel arm vertical height must both be attained at the same time within the specified load limits and height dimensions.

6. The end of the load adjusting stud (2) should not extend more than 1/4 inch (6.4 mm) beyond and not more than 1/8 inch (3.2 mm) within the face of the trunnion nut (3).
 - If adjusting stud extends more than 1/4 inch (6.4 mm) beyond the face of the trunnion nut, it may be necessary to replace the rubber cords in the torque coupling.
 - If the end of the adjusting stud is within the face of the trunnion nut, there may be foreign material lodged in the torque coupling assembly. Disassemble and clean.

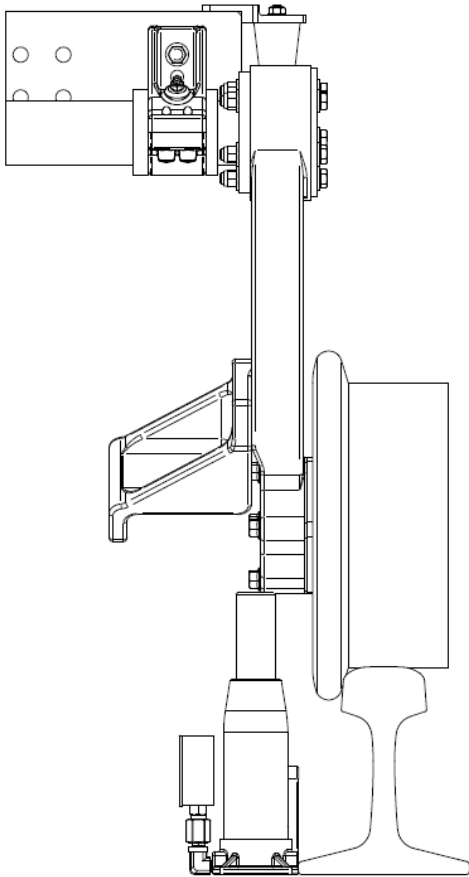

Figure 4-5
Wheel Weighing Jack

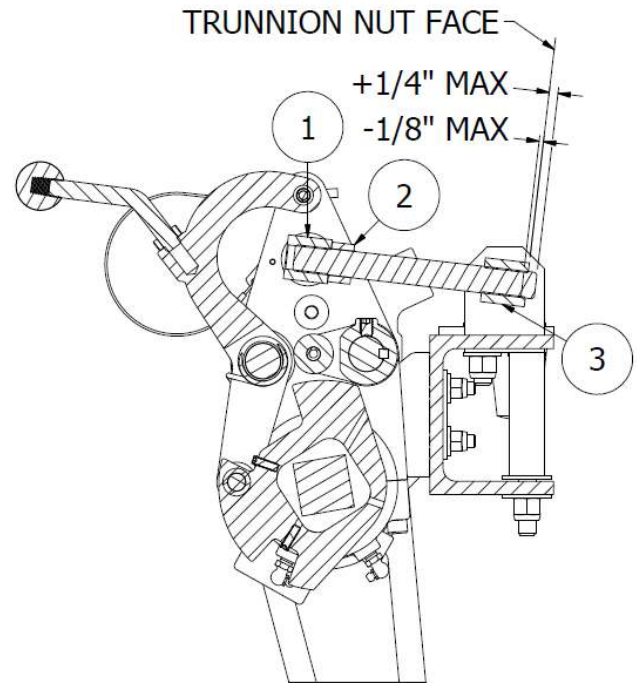

Figure 4-6
Load Adjustment Stud

Table 3: Rail Wheel Load vs Jack Pressure and Bore

Jack Pressure (PSI)	Jack Cylinder Bore Diameter (inches)								
	7/8	15/16	1	1 1/16	1 1/8	1 3/16	1 1/4	1 5/16	1 3/8
300	180	210	240	270	300	330	370	410	450
310	190	210	240	270	310	340	380	420	460
320	190	220	250	280	320	350	390	430	480
330	200	230	260	290	330	370	400	450	490
340	200	230	270	300	340	380	420	460	500
350	210	240	270	310	350	390	430	470	520
360	220	250	280	320	360	400	440	490	530
370	220	260	290	330	370	410	450	500	550
380	230	260	300	340	380	420	470	510	560
390	230	270	310	350	390	430	480	530	580
400	240	280	310	350	400	440	490	540	590
410	250	280	320	360	410	450	500	550	610
420	250	290	330	370	420	470	520	570	620
430	260	300	340	380	430	480	530	580	640
440	260	300	350	390	440	490	540	600	650
450	270	310	350	400	450	500	550	610	670
460	280	320	360	410	460	510	560	620	680
470	280	320	370	420	470	520	580	640	700
480	290	330	380	430	480	530	590	650	710
490	290	340	380	430	490	540	600	660	730
500	300	350	390	440	500	550	610	680	740
510	310	350	400	450	510	560	630	690	760
520	310	360	410	460	520	580	640	700	770
530	320	370	420	470	530	590	650	720	790
540	320	370	420	480	540	600	660	730	800
550	330	380	430	490	550	610	670	740	820
560	340	390	440	500	560	620	690	760	830
570	340	390	450	510	570	630	700	770	850
580	350	400	460	510	580	640	710	780	860
590	350	410	460	520	590	650	720	800	880
600	360	410	470	530	600	660	740	810	890
610	370	420	480	540	610	680	750	830	910
620	370	430	490	550	620	690	760	840	920
630	380	430	490	560	630	700	770	850	940
640	380	440	500	570	640	710	790	870	950
650	390	450	510	580	650	720	800	880	970
660	400	460	520	590	660	730	810	890	980
670	400	460	530	590	670	740	820	910	990
680	410	470	530	600	680	750	830	920	1010
690	410	480	540	610	690	760	850	930	1020
700	420	480	550	620	700	780	860	950	1040
710	430	490	560	630	710	790	870	960	1050
720	430	500	570	640	720	800	880	970	1070
730	440	500	570	650	730	810	900	990	1080
740	440	510	580	660	740	820	910	1000	1100
750	450	520	590	660	750	830	920	1010	1110
760	460	520	600	670	760	840	930	1030	1130
770	460	530	600	680	770	850	940	1040	1140
780	470	540	610	690	780	860	960	1060	1160
790	480	550	620	700	790	870	970	1070	1170
800	480	550	630	710	800	890	980	1080	1190
810	490	560	640	720	810	900	990	1100	1200
820	490	570	640	730	820	910	1010	1110	1220
830	500	570	650	740	830	920	1020	1120	1230
840	510	580	660	740	830	930	1030	1140	1250
850	510	590	670	750	840	940	1040	1150	1260
860	520	590	680	760	850	950	1060	1160	1280
870	520	600	680	770	860	960	1070	1180	1290
880	530	610	690	780	870	970	1080	1190	1310
890	540	610	700	790	880	990	1090	1200	1320
900	540	620	710	800	890	1000	1100	1220	1340

Rail Wheel Load (lbs)

String Lining Set-Up

1. The string lining procedure is only a guide to check and make alignment adjustments to the guide wheel equipment. String lining the vehicle and guide wheel equipment will not guarantee that the guide wheel equipped vehicle will track properly. RAFNA recommends that all Railgear equipped vehicles be track tested. The vehicle should be at its normal operating load for track testing. The vehicle should be track tested when:
 - a. The guide wheel equipment is installed on the vehicle.
 - b. Any adjustments are made to the guide wheel equipment.
 - c. The load on the vehicle is changed.
 - d. Periodically to ensure that the vehicle is tracking properly.
2. Establish parallel reference lines on each side of vehicle as shown in Figure 4-7.
3. Parallel reference lines can be established by building two supports or brackets. These can be built out of scrap angle iron or other material. The supports should be approximately 6 inches high, and a few inches longer than the width of the vehicle. Wires or cords stretched between the front and rear supports will be the reference lines. The wires or cords should be spaced approximately 72 inches apart. The distance between the wires or cords must be equal or within 1/32 inch at each support.
4. Clamp the supports to the rail in front of and behind the vehicle. The supports should be at right angles to the rail. Stretch the wires or cords between the supports, level with the bottom edge of the vehicle wheel rim (point X). The reference lines must be level.
5. Shift the supports on the rail until dimensions A, B, C, and D, are equal or within 1/32 inch. These measurements should be taken from the bead seat of the vehicle rim directly below the axle (point X) to the reference line. When shifting the supports, keep them at right angles to the rail so the reference lines stay level and parallel to each other.
6. After the reference lines have been established, measurements can be taken from these lines to the guide wheels to ensure correct alignment.

RAFNA RAILGEAR ALIGNMENT RACK DATA

GAS OR DIESEL _____ VIN# _____

VEHICLE MAKE: _____ VEHICLE MODEL: _____ VEHICLE YEAR: _____
 DOOR STICKER GVWR: _____ DOOR STICKER GAWR FRT: _____ DOOR STICKER GAWR RR _____
 RAILGEAR S/N: FRT _____ RR _____ VEHICLE UNIT #,S/N: _____
 RAILGEAR TYPE: _____ INSTALLER: _____ DATE: _____

SET UP PARALLEL STRING LINES
 A & B MUST BE EQUAL WITHIN 1/32"
 C & D MUST BE EQUAL WITHIN 1/32"

ADJUST STRING LINES AROUND VEHICLE
 E, F, G, & H MUST BE EQUAL WITHIN 1/16"
 I, J, K, & L MUST BE EQUAL WITHIN 1/16"
 (E, F, G, & H MAY NOT EQUAL I, J, K, & L)

ADJUST RAIL WHEEL ALIGNMENT
 M & O MUST BE EQUAL WITHIN 1/16"
 N & P MUST BE EQUAL WITHIN 1/16"
 Q & S MUST BE EQUAL WITHIN 1/16"
 R & T MUST BE EQUAL WITHIN 1/16"

ADJUST RAILGEAR LATERAL ALIGNMENT
 M & O MUST EQUAL N & P WITHIN 1/8"
 Q & S MUST EQUAL R & T WITHIN 1/8"

ENSURE THAT U & V ARE BETWEEN
 53- 7/16" AND 53-9/16"

OVER-CENTER ANGLE (DEGREE)
 FRONT _____
 REAR _____

RAIL WHEEL LOADS (LBS)
 LEFT FRONT _____ RIGHT FRONT _____
 LEFT REAR _____ RIGHT REAR _____

RAIL WHEEL FLANGE TO GROUND CLEARANCE
 LEFT FRONT _____ RIGHT FRONT _____
 LEFT REAR _____ RIGHT REAR _____

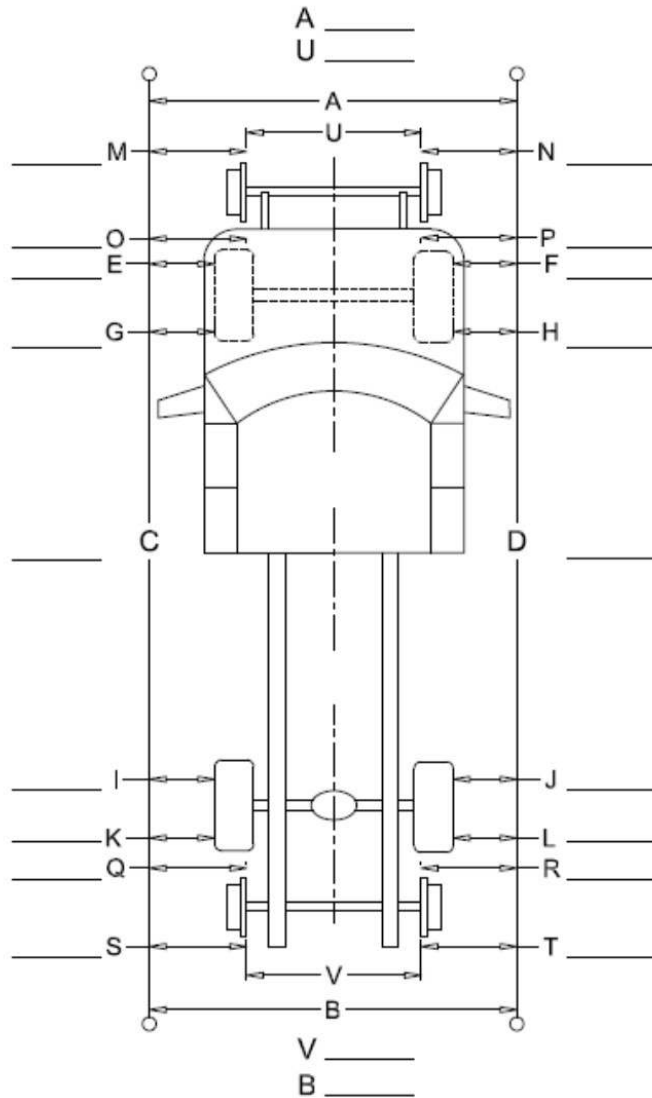

MOUNTING HEIGHT FRONT: _____ MOUNTING HEIGHT REAR: _____
 STOCK TURNING DIAMETER: _____ MODIFIED TURNING DIAMETER: _____
 OEM: VEHICLE WEIGHT: _____ FRONT GAWR: _____ REAR GAWR: _____
 MODIFIED: VEHICLE WEIGHT: _____ FRONT GAWR: _____ REAR GAWR: _____

FAX COMPLETED FORM TO JAKE SANUTE AT FAX # 570-802-0491

MAY 31, 2018 REV "D"

Checking Railgear Alignment

Lower and lock all guide wheels in the "rail" position. Take measurements M, N, O and P. Measure from the outer edge of the guide wheels, directly below the center line of the wheel spindle, to the reference line. Measurements M, N, O, and P must all be equal or within 1/16 inch. If not, see Adjustment.

Adjusting Guide Wheels

1. Unlock both front and/or both rear guide wheels from the "rail" position. Let the guide wheels rest on the rails.
2. Loosen the eight adapter bracket cap screws (4) on the top and bottom of the cross channel. Shift the entire guide wheel unit until measurements M, N, O & P are all equal. Re-tighten the cap screws.
3. Lock all guide wheels in the "rail" position. Recheck the guide wheel unit alignment.
4. Repeat the procedure until the guide wheel unit alignment is correct.
5. Lower and lock all guide wheels in the "rail" position. The guide wheels must track straight, not toed in or out. Hold a two-foot-long straight edge against the outer edge of the guide wheel with the straight edge centered on the guide wheel. Check that dimensions $G = G-1$, $H = H-1$, $K = K-1$ & $L = L1$. These dimensions must be equal or within 1/16 inch. If not, see Adjustment.

NOTE

When verifying whether the guide wheel is toed-in or toed-out, it may be helpful to visualize the traveling direction of the vehicle when in rail position.

- *The guide wheel is toed-in if the front dimension of the straight edge to the reference line is larger than the rear dimension. (Example - Left Rear Guide Wheel: Dimension G is larger than dimension G-1).*
- *The guide wheel is toed-out if the front dimension of the straight edge to the reference line is smaller than the rear dimension. (Example - Left Rear Guide Wheel: Dimension G is smaller than dimension G1).*

6. Unlock both front and/or both rear guide wheels from the "rail" position. Let the guide wheels rest on the rails.
7. Loosen the appropriate inner (1) or outer (2) pivot bearing cap screws. Add or remove shims (5) (part no. R-30067) between the pivot bearing and cross channel. Re-tighten the cap screws.

NOTE

Do not use more than two shims on any pivot bearing during the original application of the guide wheel units or three shims on any pivot bearing during field inspection and adjustment.

- Front Guide Wheel Toed In: Add shims to inner pivot bearing or remove shims from outer pivot bearing.
- Front Guide Wheel Toed Out: Add shims to outer pivot bearing or remove shims from inner pivot bearing.
- Rear Guide Wheel Toed In: Add shims to outer pivot bearing or remove shims from inner pivot bearing.
- Rear Guide Wheel Toed Out: Add shims to inner pivot bearing or remove shims from outer pivot bearing.

8. Lock all guide wheels in the "rail" position. Recheck the guide wheel unit alignment.

9. Repeat the procedure until the guide wheel unit alignment is correct.

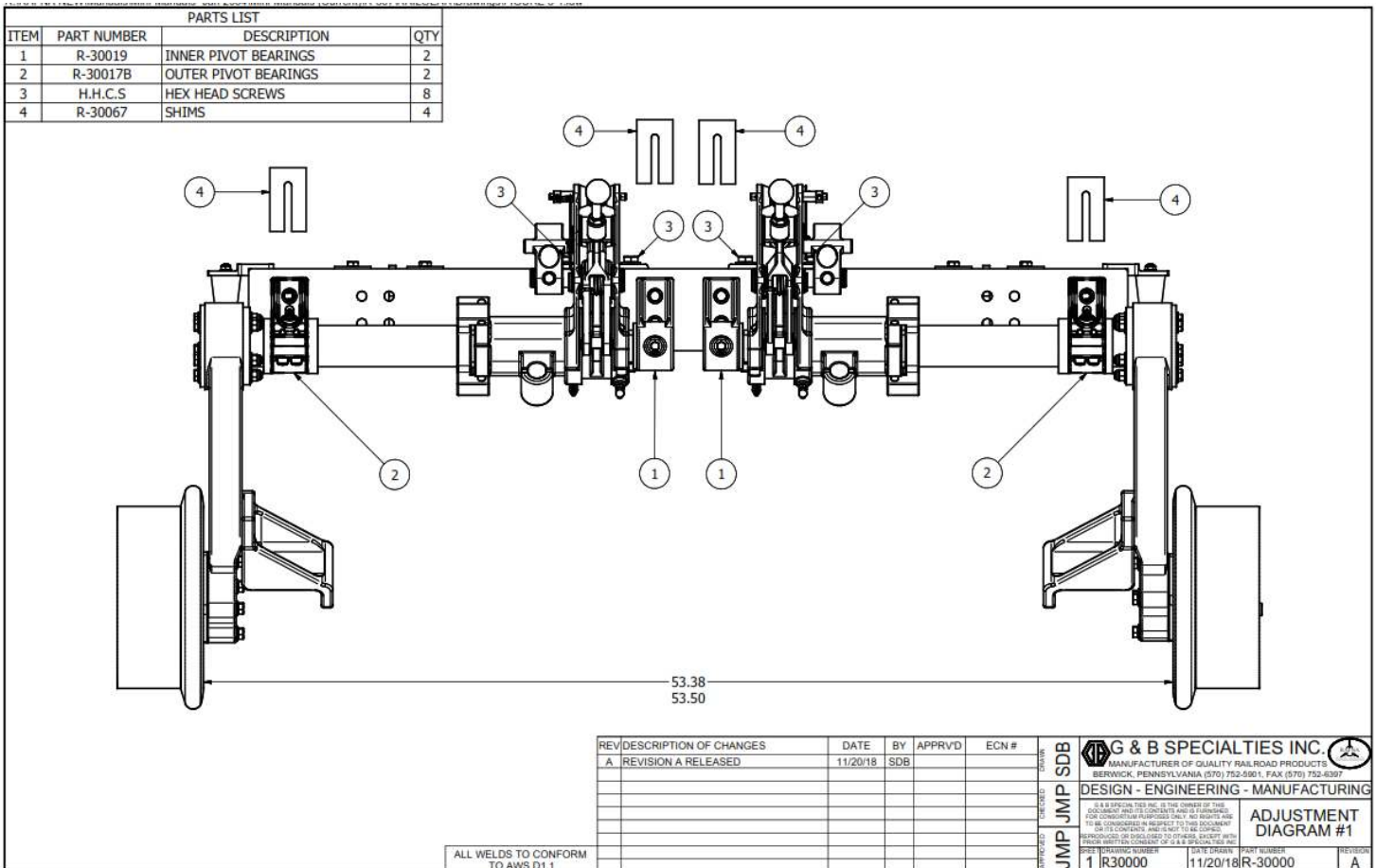

Figure 4-8: Guide Wheel Unit

Railgear Overload Set Screws

1. The "rail" overload set screws carry the load in case of an overload or a tire failure, instead of transferring the load through the rubber cords when the guide wheels are in the "rail" position. Each guide wheel has two overload set screws for a combined total of eight on the vehicle.
2. Lower and lock all guide wheels in the "rail" position. With the vehicle at curb weight, measure the distance between the set screw and the stop on the casting.

The recommended dimension for all eight overload set screws is 3/8 inch (9.5 mm).

NOTE

An easy way to check the dimension is to insert a 3/8 inch cap screw in the gap. If the cap screw slips in with little play, the overload dimension is correct. If the cap screw does not slip in or is sloppy, adjustment is necessary.

If any of the eight overload set screws are not set correctly, see Adjustment.

Adjusting Railgear Overload Set Screws

1. Insert the 3/8 inch cap screw in the gap. Tighten or loosen the set screw until the cap screw is snug with little play.
2. Repeat the procedure to set all eight overload set screws.

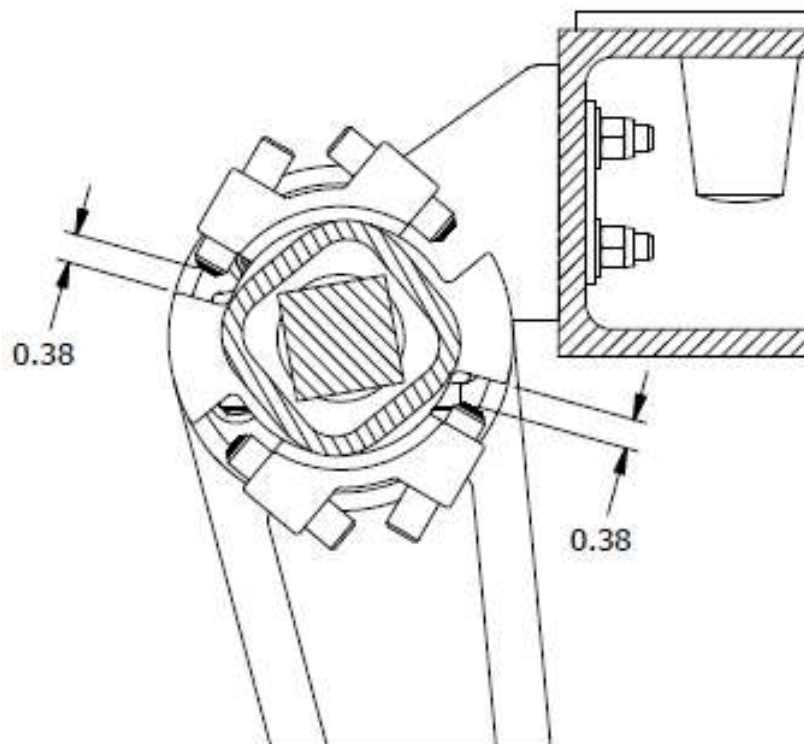

Figure 4-9: Railgear On-Rail Set Screws

Railgear Highway Set Screws

1. The highway set screws secure the guide wheel arms against the rubber bumpers on the cross frame when the guide wheel units are in the "highway" position. The rubber bumpers absorb the shocks encountered in highway driving instead of transferring the shocks through the rubber cords. Each guide wheel has two highway set screws for a combined total of eight on the vehicle.

2. Raise and lock all guide wheels in the "highway" position. The wheel arms should be solidly against the rubber bumpers. If any of the highway set screws are not set correctly, see adjustment.

Adjusting Railgear Highway Set Screws

1. Unlock the railgear from the "highway" position. Let the guide wheel rest on the rails.

2. Turn both highway set screws to move the wheel arm up or down.

3. Lock the guide wheel in the "highway" position. Recheck the guide wheel arm.

4. Repeat the procedure until the guide wheel arm is solidly against the rubber bumper. If the rubber bumper is worn so the arm cannot be adjusted solidly against it, replace the bumper.

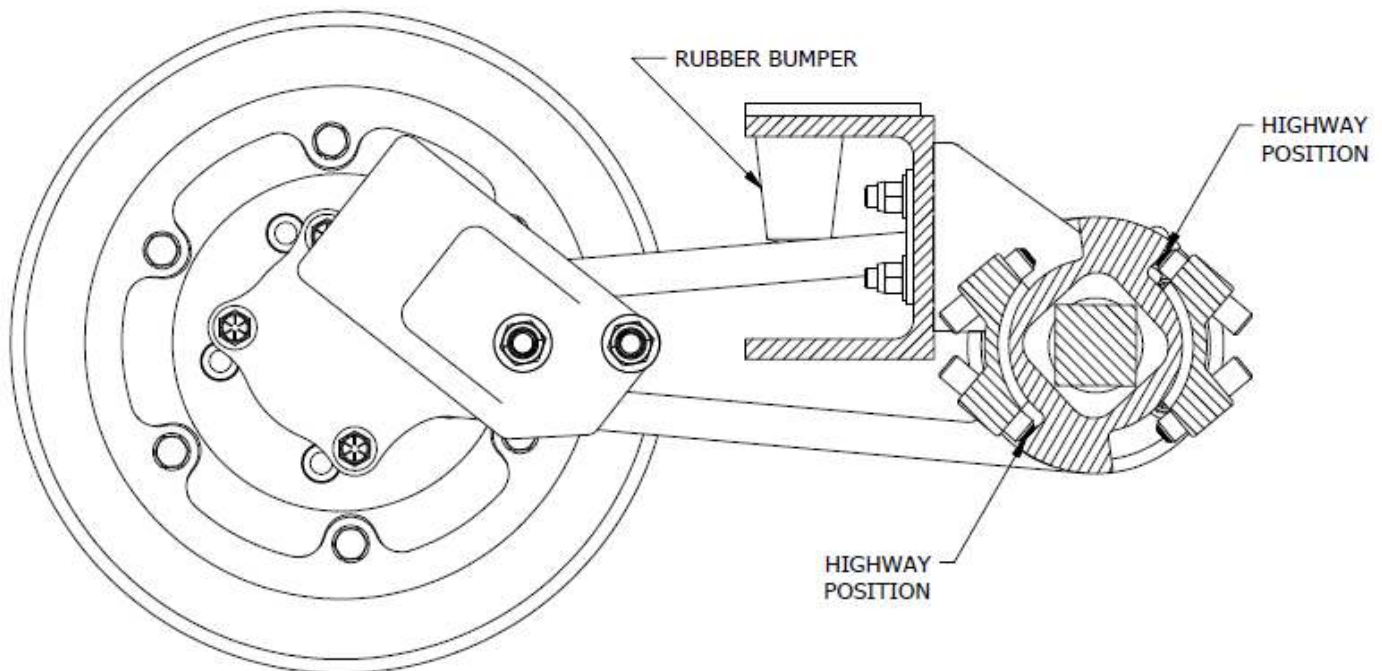

Figure 4-10: Railgear Highway Set Screws

Vehicle Track Test

WARNING

Check and correct alignment promptly if misalignment is indicated. Misalignment of guide wheel equipment could result in derailment of the vehicle and severe bodily injury.

1. RAFNA recommends that all railgear equipped vehicles be track tested. The vehicle should be at its normal operating load for track testing. The vehicle should be track tested when:
 - a. The railgear is installed on the vehicle.
 - b. Any adjustments are made to the railgear.
 - c. The load on the vehicle is changed.
 - d. Periodically to ensure that the vehicle is tracking properly.
2. The vehicle must be placed on straight, level, tangent track.
3. Apply spray paint to the flanges and treads of all guide wheels.
4. Lower and lock all guide wheels in the "rail" position.
5. Operate the vehicle a minimum of 1/4 mile at a normal operating speed.
6. The paint should wear evenly around the flanges and treads of all guide wheels. If the paint is worn evenly on all guide wheels, the vehicle and guide wheel equipment is properly aligned.
7. If the paint did not wear evenly, note which guide wheels, flange and / or tread the paint is worn on.
 - a. Repaint the flanges and treads on all guide wheels.
 - b. Operate the vehicle in reverse for a short distance at a normal operating speed.
 - c. Note which guide wheels, flange and / or tread the paint is worn on. If the paint wore off on the right front flange when traveling forward and then on the left rear flange when traveling in reverse, the vehicle is probably not aligned properly. Have the vehicle frame checked for proper alignment. See Vehicle Check.
8. See Figure 4-8. If the vehicle pulls noticeable to the right when traveling forward, add a shim (5) (part no. R-30067) behind the right front outer bearing. Do not use more than two shims on any pivot bearing during the original application of the guide wheel units or three shims on any pivot bearing during field inspection and adjustment.
9. If the vehicle pulls noticeable to the left when traveling forward, add a shim (5) (part no. R-30067) behind the left front outer bearing. Do not use more than two shims on any pivot bearing during the original application of the guide wheel units or three shims on any pivot bearing during field inspection and adjustment.

ADJUSTMENTS

Locking Mechanism

The spring-loaded locking mechanism should move freely so it engages itself when the guide wheel is raised or lowered. Periodically inspect this area for wear. When the vehicle is operated in mud or slush, foreign material may get into the locking mechanism, preventing the lock from operating correctly. Remove this foreign material, being careful not to damage the locking mechanism.

The locking mechanism is secured in the "rail" or "highway" position by a lock pin inserted through the pawl handle and the side plates of the locking mechanism. The lock pin must insert easily in either position. If not, re-align.

The button in the lock pin must push in easily and also pop out when released. The locking balls in the end of the pin must work freely so the pin cannot be removed until the button in the lock pin is pushed in. If the lock pin does not operate properly, replace the pin.

1. Place the vehicle on straight, level track. Place the automatic transmission in "Park" or manual transmission in "Neutral". Apply the parking brake. Stop the engine.
2. For rail position adjustment, do the following:
 - Lower and lock all four guide wheels in the "rail" position.
 - If the lock pin (1) cannot be inserted or is hard to insert, re-align the locking pawl.
 - To re-align, adjust the set screw (2) so the hole in the pawl handle (4) aligns with the holes in the side plates (5). Turn the screw clockwise to move the hole in the pawl handle towards the vehicle. Turn the screw counter-clockwise to move the hole in the pawl handle away from the vehicle.
3. For highway position adjustment, do the following:
 - Raise and lock all four guide wheels in the "highway" position.
 - If the lock pin (1) cannot be inserted or is hard to insert re-align the locking pawl.
 - To re-align, adjust the set screw (3) so the hole in the pawl handle (4) aligns with the holes in the side plates (5). Turn the screw clockwise to move the hole in the pawl handle towards the vehicle. Turn the screw counter-clockwise to move the hole in the pawl handle away from the vehicle.

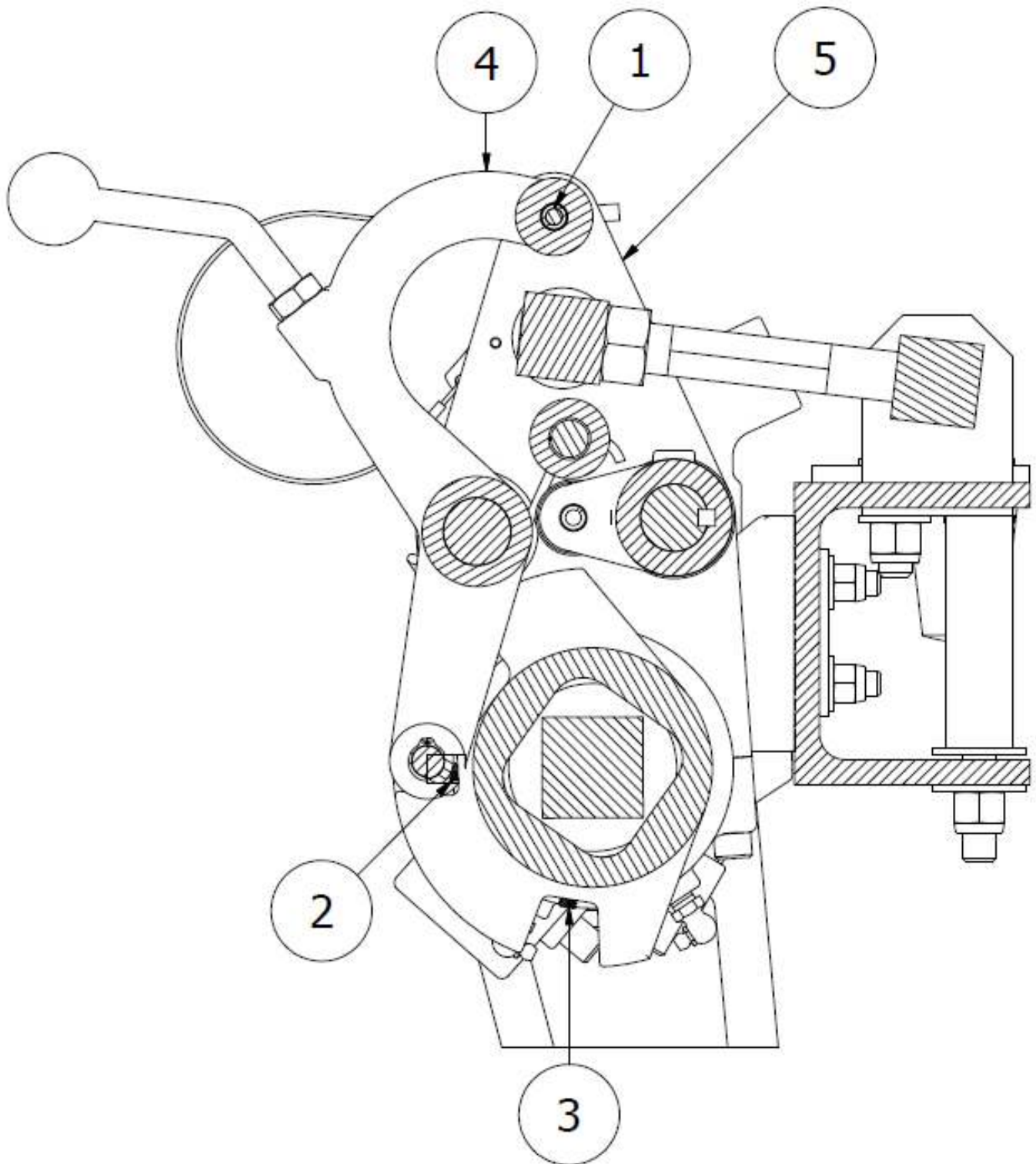

Figure 4-11 Locking Mechanism

Rail Sweeps

1. Place the vehicle on straight, level track. Place the automatic transmission in "Park" or manual transmission in "Neutral". Apply the parking brake. Stop the engine.
2. Lower and lock all four guide wheels in the "rail" position, the rail sweeps will lower to the rail position when the guide wheels are lowered.
3. The rubber sweep pad (1) should clear the top of the rail by 1/4 inch (6.4 mm). If not, adjustment is necessary.
4. Loosen the two cap screws (2). Slide the rubber sweep (1) down until it clears the top of the rail by 1/4 inch (6.4 mm). Re-tighten the cap screws.
5. If the rubber sweep (1) cannot be lowered, remove the two cap screws (2). Relocate the cap screws in the next upper set of holes in the rubber sweep (1). Then adjust the sweep. See Step 4.
6. If the rubber sweep (1) is in the last, upper set of holes and cannot be adjusted, replace the rubber sweep.

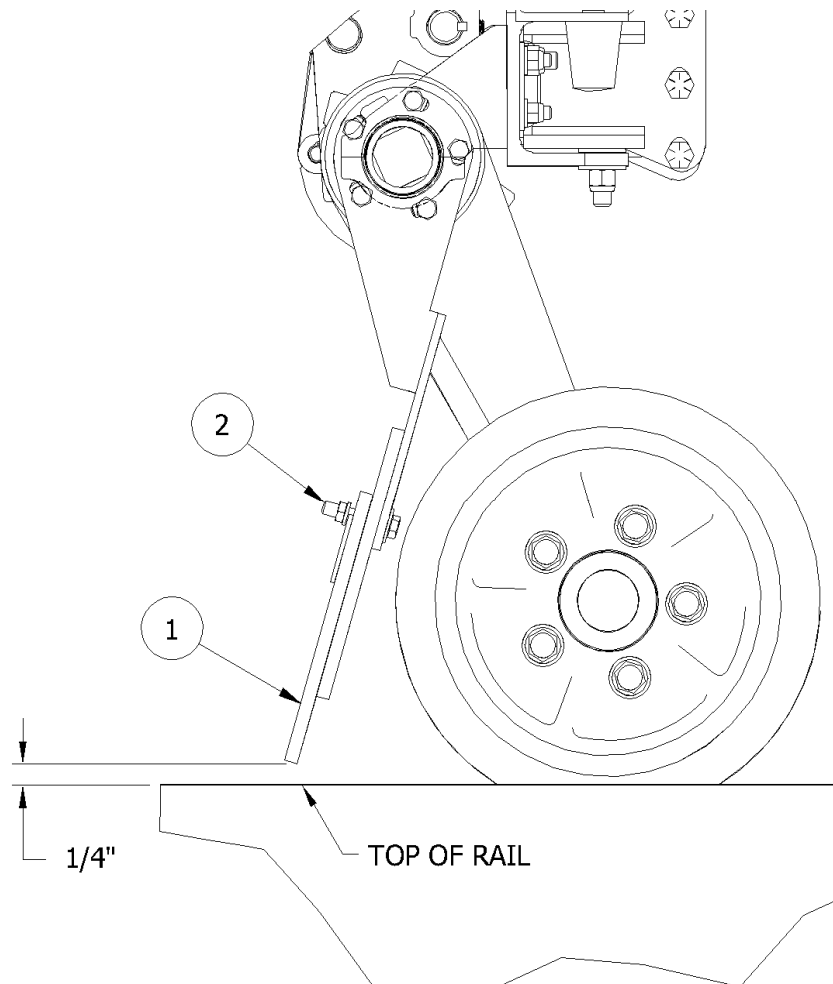

Figure 4-12: Rail Sweep

5.0 MAINTENANCE

WHEEL BOLTS AND LUGS

Re-torque vehicle wheel lug nuts, wheel spacer lug nuts, and guide wheel lug nuts, after the first 50 miles of operation. Thereafter torque wheel nuts according to recommended maintenance schedule to the torque value specified in appendix (A). If a bolt replacement becomes necessary, replace the worn bolt with an equal grade bolt. Lug nut detachment, or bolt failure, may lead to severe bodily injury or vehicle damage.

MAINTENANCE SCHEDULE

Daily:

1. Inspect both front and rear guide wheel units for damaged or missing parts.
2. Note the amount of effort required to lower and raise the guide wheels. Effort required should be about the same for each guide wheel. The rear guide wheels, which are locked in the rail position first, should be somewhat easier to lower.
3. Check the locking mechanism for ease of operation. The lock pins should never be able to be pulled out unless the button on the "T" end is pushed in. The button in the lock pin must push in easily and pop out when released. The locking balls in the end of the pin must work freely so the pin cannot be removed until the button in the lock pin is depressed. If the lock pin does not operate properly, replace the lock pin.
4. When the vehicle is operated on the track, listen for unusual noises. Unusual noises may indicate incorrectly lowered guide wheels, or damaged or missing parts. Pay attention to the quality of the ride. Check alignment if the vehicle crowds one side of the track instead of floating from side to side. See Adjustment - Railgear Alignment Procedure.

Weekly:

1. Check railgear alignment. See Adjustments Section, Railgear Alignment Procedure - Vehicle Track Test.
2. Inspect guide wheel tread and flanges for wear or damage. See Maintenance - Guide Wheel Allowable Wear.
3. Spin each guide wheel by hand, checking for ease of rotation or excessive play. If the guide wheel does not rotate properly, the bearings and spindle may be damaged. Replace the bearing/spindle assembly if necessary.
4. Inspect vehicle wheels, studs, lug nuts and tires for wear, damage, cuts, etc.
5. Check vehicle tires for correct inflation pressure. Operate at the tire manufacturer's recommended maximum pressure printed on the sidewalls of the tires or the wheel manufacturer's recommended maximum pressure stamped on the wheel, whichever is lower.
6. Check guide wheel unit pivot bearings for tightness.

At 50 Vehicle Miles (80 Vehicle km):

1. Torque wheel spacer lug nuts, vehicle wheel lug nuts and guide wheel lug nuts to the recommended specifications. See the decal attached to the vehicle wheel for the recommended wheel bolt torque specifications. Thereafter refer to the wheel manufacturer's wheel torque specifications.
2. At 50 track miles (80 Km) after initial installation of the guide wheel unit, torque guide wheel lug nuts to the recommended specifications.

Every 2000 Track Miles (3200 Track km):

1. Lubricate guide wheel unit locations provided with grease fittings. See Lubrication.
2. Lubricate the locking mechanism and other pivot points with light oil or a lubricating spray.
3. Torque guide wheel lug nuts to 90 ft lbs (122 N-m).

NOTE

The operation and maintenance of RAFNA equipment may involve the use of such items as hydraulic oil, engine oil, fuel, coolant, brake fluid, filters, batteries, etc.

Dispose of waste properly. Improper disposal of waste can threaten the environment. Use leak proof containers when draining fluids. Do not pour waste onto the ground, down a drain, or into any water source. Inquire on the proper way to recycle or dispose of waste according to applicable Federal, State and/or local regulations.

RAILGEAR UNIT LUBRICATION

1. Lubricate the railgear equipment every 2000 track miles (3200 track km) maximum or each time the vehicle is serviced.
2. Apply the vehicle parking brake. Stop the engine.
3. Lubricate all grease fittings (A) using Mobil Special Moly, or equivalent.
4. Lubricate the locking mechanism and other pivot points with a light weight oil or a lubricating spray.

NOTE

R-307A Railgear utilizes sealed bearings in the guide wheels. Do not re-pack the guide wheel bearings. If the bearings are worn, replace the spindle, hub and bearing assembly.

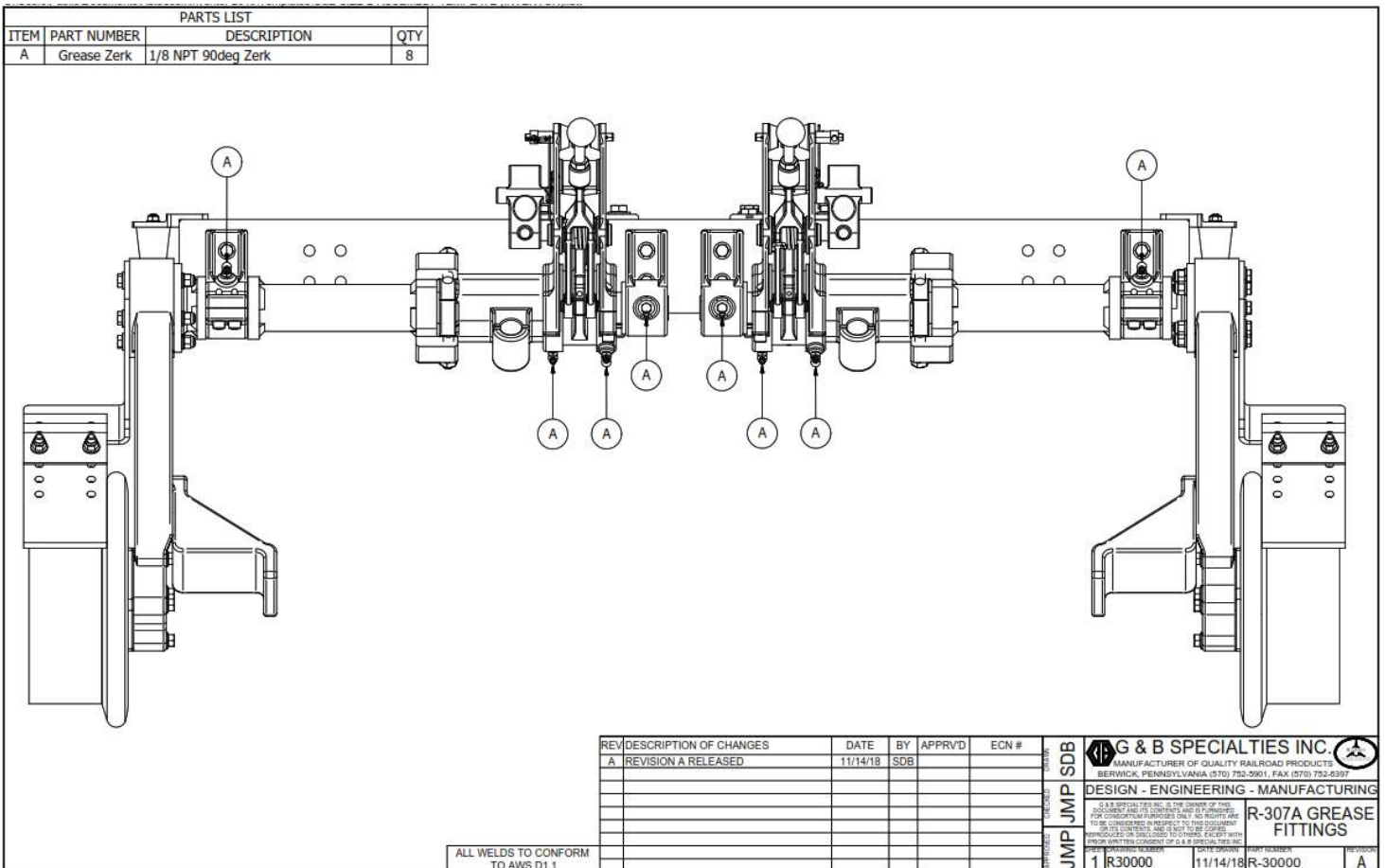

Figure 5-1: Guide Wheel Unit Lubrication Diagram

GUIDE WHEELS

Allowable Wear - Aluminum Wheel with Rubber Tread

CAUTION

Immediately replace any guide wheel which shows damage, and/or has worn more than the allowable limits. Failure to comply could result in derailment of the vehicle, and severe bodily injury.

1. Tools needed: Wheel Caliper measuring tool.
2. Measure the wheel flange at position "A" with the wheel caliper.
The minimum allowable flange dimension is:
 - Position "A".....1/4 inch (6.4 mm)*If the wheel flange dimension is less than the allowable limit, replace the wheel immediately.*
3. Measure the wheel tread at positions "B" and "C" with the wheel caliper.
The minimum allowable tread dimensions are:
 - Position "B".....11/16 inch (17.5 mm)
 - Position "C"11/16 inch (17.5 mm)*If any of the guide wheel tread dimensions are less than the allowable limits, replace the wheel immediately.*
4. The rubber tread must not have gouges. The aluminum wheel and/or flange must not have hairline cracks. If any of these are evident, replace the wheel immediately.

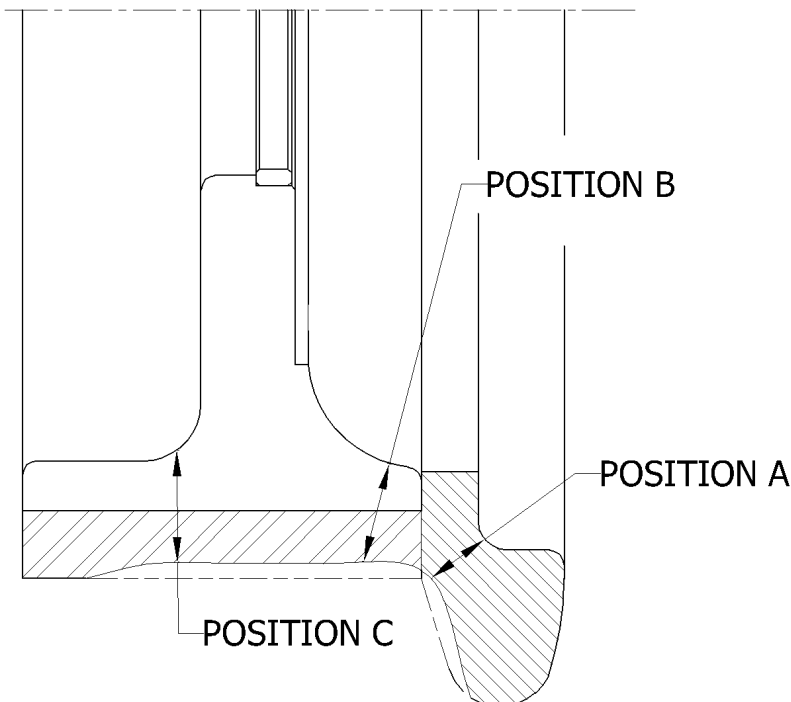

Figure 5-2: Allowable Wear - Aluminum Guide Wheel with Rubber Tread

Guide Wheel Check

Guide wheels which do not run true on the tread and flange will vibrate and give a rough ride. Additionally, there may be foreign matter (dirt, rust, paint, etc.) between the wheel and hub, the spindle bearings may be worn, or the tread and flange of the wheel may be worn or damaged, causing a wobbling sensation. On wheels with rubber tread, there may also be foreign matter lodged between the mating surfaces of the steel flange and the aluminum wheel, giving the same sensation.

1. Verify that the five lug nuts are torqued properly to 90 ft lbs (122 N-m). Tighten if necessary.
2. Rubber Guide Wheels Only: Verify that the six 3/8-inch hex flange head cap screws securing flange to the rubber tread wheel are torqued properly to 40 ft lbs (55 N-m).
3. Track test the vehicle to verify whether the vibrations were caused by loose guide wheels or flanges. If track testing shows that the vibrations persist, go on to the following steps.
 - Check the spindle bearing by grasping the guide wheel and working it from side to side. If there is excessive play in the spindle, remove the guide wheel and verify that the four 3/8-inch cap screws that secure the spindle to the wheel arm are properly torqued to 31 ft lbs (42 N-m). Re-tighten if necessary.
 - Recheck the spindle bearing by grasping the spindle and working it from side to side. If there is excessive play in the spindle bearing, the bearings are worn. Replace the spindle and hub assembly.
 - Check for foreign material on the mating surfaces of the guide wheel and the hub. Remove any foreign material on these surfaces.
 - Rubber Guide Wheels Only: Remove the flange from the guide wheel and check for foreign material on the mating surfaces of the flange and the guide wheel. Remove any foreign material on these surfaces. Reinstall the flange on the guide wheel and torque the fasteners to 40 ft lbs (55 N-m).
 - Reinstall the guide wheel onto the spindle and hub. Torque wheel nuts to 90 ft lbs (122 N-m).
 - Track test the vehicle to verify whether the vibrations were caused by worn spindle bearings or foreign material between guide wheel/flange mounting surfaces.
4. If track testing shows that the vibrations persist, the wheel may be sprung or bent. Replace the wheel.

LOCKING MECHANISM

The spring-loaded locking mechanism should move freely so that it engages itself when the guide wheel is raised or lowered. Periodically inspect this area for worn or damaged parts. When the vehicle is operated in muddy or slushy conditions, foreign material may get into the locking mechanism, preventing the lock from operating correctly. Remove this foreign material, being careful not to damage the locking mechanism.

The locking mechanism is secured in the "rail" or "highway" position by a lock pin inserted through the pawl handle and side plates of the locking mechanism. The lock pin must insert easily in either position. If not, re-adjust. See Adjustment Section - Locking Mechanism. The button in the locking pin must push in easily and also pop out when released. The locking balls in the end of the pin must work freely so the pin cannot be removed until the button in the locking pin is pushed in. If the lock pin does not operate properly, replace the pin.

PIVOT BEARINGS

The inner and outer pivot bearings on the guide wheel unit should be checked carefully at weekly intervals for wear. To check the bearings, apply the parking brake. The guide wheels must be raised to the "highway" position.

Insert a pry bar between the cross channel and the pivot. Check for looseness. The pivot bearings are nonadjustable. If the pivot bearings are worn, replace them.

RUBBER CORD REPLACEMENT

See the Section 4, 4.1 Guide Wheel Equipment Alignment Procedure. The end of the load adjustment stud, behind the locking pawl mechanism, should not extend more than 1/4 inch (6.4 mm) beyond and not more than 1/8 inch (3.2 mm) within the face of the trunnion nut.

If the adjusting stud extends more than 1/4 inch (6.4 mm) beyond the face of the trunnion nut, it may be necessary to replace the rubber cords in the torque coupling.

VEHICLE WHEELS

Wheel Replacement

Use replacement wheel rim(s) as recommended by RAFNA to ensure correct vehicle wheel spacing and accurate guide wheel load. The wheels and tires should be static balanced or balanced after installation on the vehicle for the best results. Torque vehicle wheel lug nuts to recommended specifications. See the decal attached to the vehicle wheel for the recommended wheel bolt torque specifications.

WARNING

Use replacement wheel(s) as recommended in the RAFNA railgear vehicle specifications manual. Failure to comply could result in bodily injury and/or property damage.

Tire Replacement

Replacement tires must have the same rolling radius, tread width, ply rating, and load rating as recommended by RAFNA. Using tires of equal diameter will help keep the speedometer reading and the guide wheel load accurate. Tires must have a minimum 5-1/2 inches of tread width. After installing new tire(s) on the vehicle, check guide wheel load. See the Adjustment Section - Railgear Alignment Procedure.

Inflate tires to the tire manufacturer's recommended maximum pressure printed on the sidewalls of the tires or the wheel manufacturer's recommended maximum pressure stamped on the wheel, whichever is lower. The wheels and tires should be static balanced or balanced after installation on the vehicle for the best results. Torque vehicle wheel lug nuts to recommended specifications. See the decal attached to the vehicle wheel for the recommended wheel bolt torque specifications.

WARNING

Failure to comply with the above requirements could lead to insufficient vehicle traction, leading to tire damage, loss of control, and/or bodily injury.

6.0 TROUBLESHOOTING

TROUBLESHOOTING GUIDE WHEEL EQUIPMENT

Problem	Probable Causes	Possible Remedies
Extreme effort required to unlock and lower or raise guide wheels.	<p>Components bent, broken, etc.</p> <p>Foreign material (mud, slush, dirt, etc.) in torque coupler.</p> <p>Pivot bearings are dirty and/or not lubricated.</p>	<p>Replace components.</p> <p>Clean.</p> <p>Disassemble and clean. Lubricate.</p>
Extreme effort required to lock or unlock guide wheels in the "rail" position.	<p>Vehicle incorrectly loaded or overloaded.</p> <p>Vehicle tires under-inflated.</p> <p>Guide wheel unit wheel arm height and/or guide wheel load adjusted incorrectly.</p>	<p>Redistribute or remove some of the load.</p> <p>Check tire pressure. Inflate if low. Do not exceed the tire manufacturer's recommended maximum pressure printed on the sidewalls. Do not exceed the wheel manufacturer's recommended maximum pressure stamped on the wheel.</p> <p>Re-adjust. See Adjustment Section - Guide Wheel Equipment Alignment Procedure.</p>
Minimal effort required to lock or unlock guide wheels in the "rail" position.	<p>Vehicle tires are over-inflated.</p> <p>Guide Wheel unit wheel arm height and/or guide wheel load adjusted incorrectly.</p>	<p>Check tire pressure. If too high, deflate to the tire manufacturer's recommended maximum pressure printed on the sidewalls or wheel manufacturer's recommended maximum pressure, stamped on the wheel, whichever is lower.</p> <p>Re-adjust. See Adjustment Section - Guide Wheel Equipment Alignment Procedure.</p>

Problem	Probable Causes	Possible Remedies
<p>Vehicle pulls noticeably to the left or right when on track.</p>	<p>Vehicle loaded heavy on one side.</p> <p>Steering lock not engaged.</p> <p>Vehicle wheels not aligned with steering lock when engaged.</p> <p>Guide wheels are not aligned with vehicle.</p> <p>Vehicle front tires out of alignment.</p>	<p>Move load to center of vehicle.</p> <p>Engage the steering lock.</p> <p>Re-align. See Adjustment Section - Guide Wheel Equipment Adjustment Procedure.</p> <p>Re-align. See Adjustment Section - Guide Wheel Equipment Alignment Procedure.</p> <p>Re-align front tires.</p>
<p>Vehicle derails.</p>	<p>Guide wheel units, vehicle axle(s), etc. not aligned with vehicle frame.</p>	<p>Check alignment. See Adjustment Section - Guide Wheel Equipment Alignment Procedure.</p>
<p>Unusual or excessive noise when traveling on track.</p>	<p>Guide wheel spindle bearings worn.</p> <p>Guide wheel unit flanging hard to the right or left.</p>	<p>Replace bearing/spindle assembly.</p> <p>Re-align. See Adjustment Section - Guide Wheel Equipment Alignment Procedure.</p>

Problem	Probable Causes	Possible Remedies
<p>Vibration felt in the vehicle when traveling on track.</p>	<p>Guide wheel unit mounting hardware loose.</p> <p>Guide wheel spindle bearings worn.</p> <p>Guide wheel worn or damaged.</p> <p>Guide wheel unit pivot bearings worn.</p> <p>Vehicle rim bent.</p> <p>Vehicle tires out of balance.</p> <p>Wheel spacer lug nuts and or vehicle lug nuts loose.</p>	<p>Tighten all bolts to recommended torque.</p> <p>Replace bearing/spindle assembly.</p> <p>Replace guide wheel.</p> <p>Check inner and outer pivot bearings. See Maintenance Section - Pivot Bearings.</p> <p>Replace rim. See Maintenance Section - Vehicle Wheels.</p> <p>Balance tires. See Maintenance Section - Tire Replacement.</p> <p>Torque wheel spacer lug nuts and vehicle lug nuts to recommended specifications. See maintenance Section.</p>

Problem	Probable Causes	Possible Remedies
<p>Vibration felt in the vehicle when traveling on road.</p>	<p>Guide wheels are not locked and secured in "highway" position</p> <p>Guide wheel unit mounting hardware loose.</p> <p>Guide wheel "highway" set screws are adjusted incorrectly.</p> <p>Vehicle wheel bent.</p> <p>Vehicle tires out of balance.</p> <p>Wheel spacer lug nuts and or vehicle lug nuts loose.</p>	<p>STOP IMMEDIATELY. Make sure all four guide wheels are locked and secured in "highway" position.</p> <p>Tighten all bolts to recommended torque.</p> <p>Check to see that wheel arms are tight against rubber bumper on the cross tube. If rubber bumper is worn, replace it.</p> <p>Replace wheel. See Maintenance Section - Vehicle Wheels.</p> <p>Balance tires. See Maintenance Section - Tire Replacement/Balancing.</p> <p>Torque wheel spacer lug nuts and vehicle lug nuts to recommended specifications. See maintenance Section.</p>

Problem	Probable Causes	Possible Remedies
<p>Guide wheel "rail" overload set screws bottomed out.</p>	<p>Vehicle incorrectly loaded or overloaded.</p> <p>Vehicle tires under-inflated.</p> <p>Guide wheel arm height and/or guide wheel load adjusted incorrectly.</p> <p>"Rail" overload set screws adjusted incorrectly.</p> <p>Rubber cords in torque coupler worn.</p> <p>Foreign material (mud, slush, dirt, etc.) in torque coupler.</p>	<p>Redistribute or remove some of the load.</p> <p>Check pressure. Inflate if low. Do not exceed tire manufacturer's recommended maximum pressure printed on the sidewalls or wheel manufacturer's recommended maximum pressure stamped on the wheel, whichever is lower.</p> <p>Re-adjust. See Adjustment Section - Guide Wheel Equipment Alignment Procedure.</p> <p>Re-adjust. See Adjustment Section - Guide Wheel Equipment Alignment Procedure.</p> <p>Have rubber cords replaced.</p> <p>Clean.</p>

WARRANTY

G&B SPECIALTIES, INC. LIMITED WARRANTY

G&B Specialties warranty covers a period of TWELVE (12) months after the date of the railgear's entry into service. This warranty applies to the Railgear itself, along with the hydraulic pump/motor assembly provided with our R-290 Railgear. The warranty asserts that each new railgear sold will be free from defects in material and workmanship under normal use and service. G&B Specialties' obligation under this warranty is limited to repairing or replacing at its factory, or other locations as designated by the company. Any defective part or parts must be returned within 30 days of the date of failure or notice of defect for factory inspection or as designated by G&B Specialties, Inc.

Equipment or parts not manufactured by G&B Specialties, but which are furnished in connection with G&B Specialties products are covered directly and solely by the warranty of the original equipment manufacturer supplying them.

The obligation of G&B Specialties under this warranty is limited to the replacement of parts that appear to be defective after review and inspection by our firm or designated representative. This warranty does not oblige G&B Specialties to bear the Customer's cost of labor or transportation charges concerning the return of defective parts. However, if found to be defective the outbound direct ground freight on the part will be prepaid to locations within continental United States and Canada by G&B Specialties, Inc. The warranty does not cover normal wear parts such as rail wheels, guide tubes, bearings, seals, rail sweeps or responsibility for customer's claims arising from abuse, misuse, neglect, or alteration of the railgear. All claims are subject to inspection of said parts by our firm.

This warranty is in lieu of other warranties, expressed or implied, including any implied warranties of merchantability or fitness for a particular purpose and any liability for special or consequential damages.

PRODUCT IMPROVEMENT LIABILITY DISCLAIMER

G&B Specialties, Inc. reserves the right to make any changes in or improvements on its products without incurring any liability or obligation whatever and without being required to make any corresponding changes or improvements in products previously manufactured or sold.

IMPORTANT NOTICE

This warranty will be considered void if G&B Specialties Installation instructions or Service and Maintenance schedule is not followed according to the detailed instructions contained in both our Installation Manual and our Operation and Service Manual.

WARRANTY POLICIES AND PROCEDURES FOR INSTALLERS AND CUSTOMERS

Installers & Customer Warranty:

To prevent unnecessary delays or misunderstandings in handling Installers' or Customers' warranty claims, it is required that all warranty requests be authorized prior to any repairs, modifications or adjustments being started.

Warranty information and authorization can be obtained from G&B Specialties.

G&B Specialties' warranty will not apply if the railgear or any of its components have been modified or replaced without the written consent of the company.

Additional Billing, Installers & Customers:

If during installation, it is found that incorrect parts have been shipped, G&B Specialties will cover all costs involved in replacing these parts and return of incorrectly shipped parts.

All warranty claims concerning short / incorrect shipment of parts or accessories must be made within 30 days of delivery.

To maintain control over extra or additional billing due to incorrect shipments, only the Engineering Manager or Customer Service Manager can issue a Purchase Order authorizing replacement parts, shipping or work to be performed by an outside source.

Warranty Claim information and requirements:

G&B Specialties will require the following information at time of claim as well as the a properly filled out "Warranty Claim Form" reference "Warranty Form v#2 04/01"

- Information Required:
- 1) Customer Purchase Order number.
 - 2) G&B Specialties railgear serial number.
 - 3) Vehicle unit number.
 - 4) Vehicle VIN number.
 - 5) Purchaser of G&B Specialties railgear.
 - 6) Date of purchase.
 - 7) Name of end user.
 - 8) Company requesting warranty claim.
 - 9) Ship to Address.
 - 10) Bill to Address.

On approval of warranty claim, and where return of parts is requested by G&B Specialties, the Installer or Customer will issue a Purchase Order to G&B Specialties, Inc. to cover the defective parts and out bound freight for part values exceeding \$50.00 US and \$75.00 CDN. G&B Specialties will in turn ship all required parts pre-paid ground direct to the Installer or Customer. On receipt of claimed warranty parts, G&B Specialties or their sub supplier will inspect defective parts and if deemed warranty, a credit will be issued to the Installer or Customer. If claimed warranty parts are not received within 30 days, a credit will not be issued.

Labor Warranty and /or additional labor charges:

Either the G&B Specialties Warranty or any of G&B Specialties sub-suppliers does not cover labor or additional labor charges such as travel.

Faulty Railgear Installations:

If a warranty claim arises due to incorrect installation by an installer who has not followed the written instructions as outlined in our manual or as trained by either G&B Specialties Customer Service or Sales Department, warranty claims will not be honored.

Parts Warranty:

G&B Specialties manufactured parts will be warranted and replaced if found to be defective due to poor materials or workmanship for up to one year from date of the railgear's entry into service. Parts not manufactured by G&B Specialties, Inc. will be covered by the Original Equipment Manufacturer's warranty. Based on the OEM's investigation of the warranty claim against their manufactured component their decision will stand.

WARRANTY CLAIM FORM

This form must be completed prior to starting any warranty work

Warranty # _____

Customer		Date	
Tel/Fax		Railgear S/N	
Vehicle No.		Vehicle VIN	
End User		Date of Purchase	
P.O. Number		Ref #	
Inv. Address		Ship to Address	
Inv. Address		Ship to Address	
Inv. Address		Ship to Address	
Inv. Address		Ship to Address	

Shipping instructions:
Shipper:

Standard Ground	Special Air
---------------------------	----------------

Standard 5 days +	Select 3 days	Expedition 2-3 day	Express 2 days
----------------------	------------------	-----------------------	-------------------

Way Bill # _____

PART No.	QUANTITY	DESCRIPTION

PROBLEM DESCRIPTION

Required Documentation from the Customer (For issuing Credit)

Description of G&B Specialties Parts (Ordered or Used)	Invoice #	Total Claimed \$	US/CAD

G&B SPECIALTIES approved by: _____ DATE: _____

CUSTOMER'S REPRESENTATIVE: _____ DATE: _____

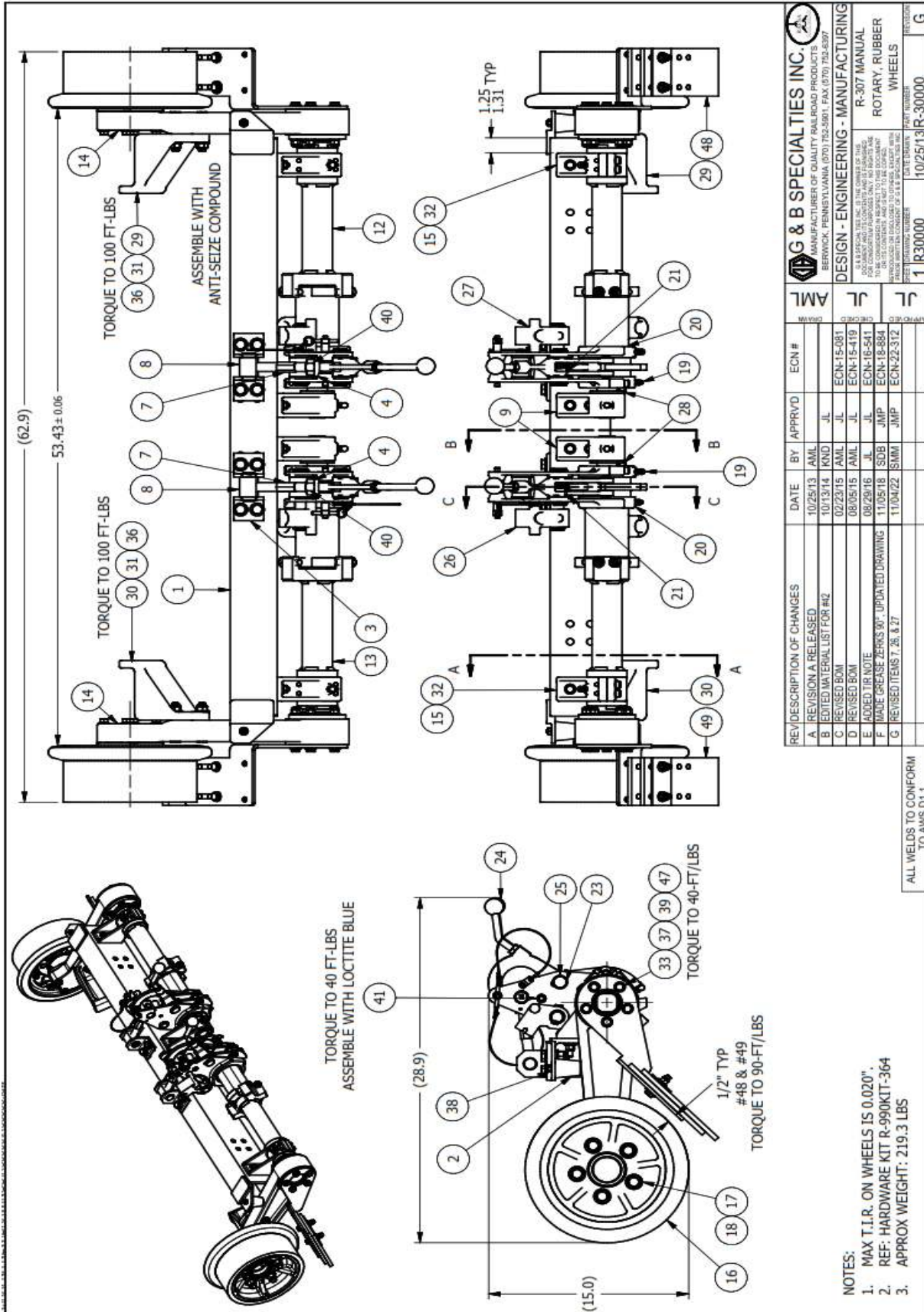

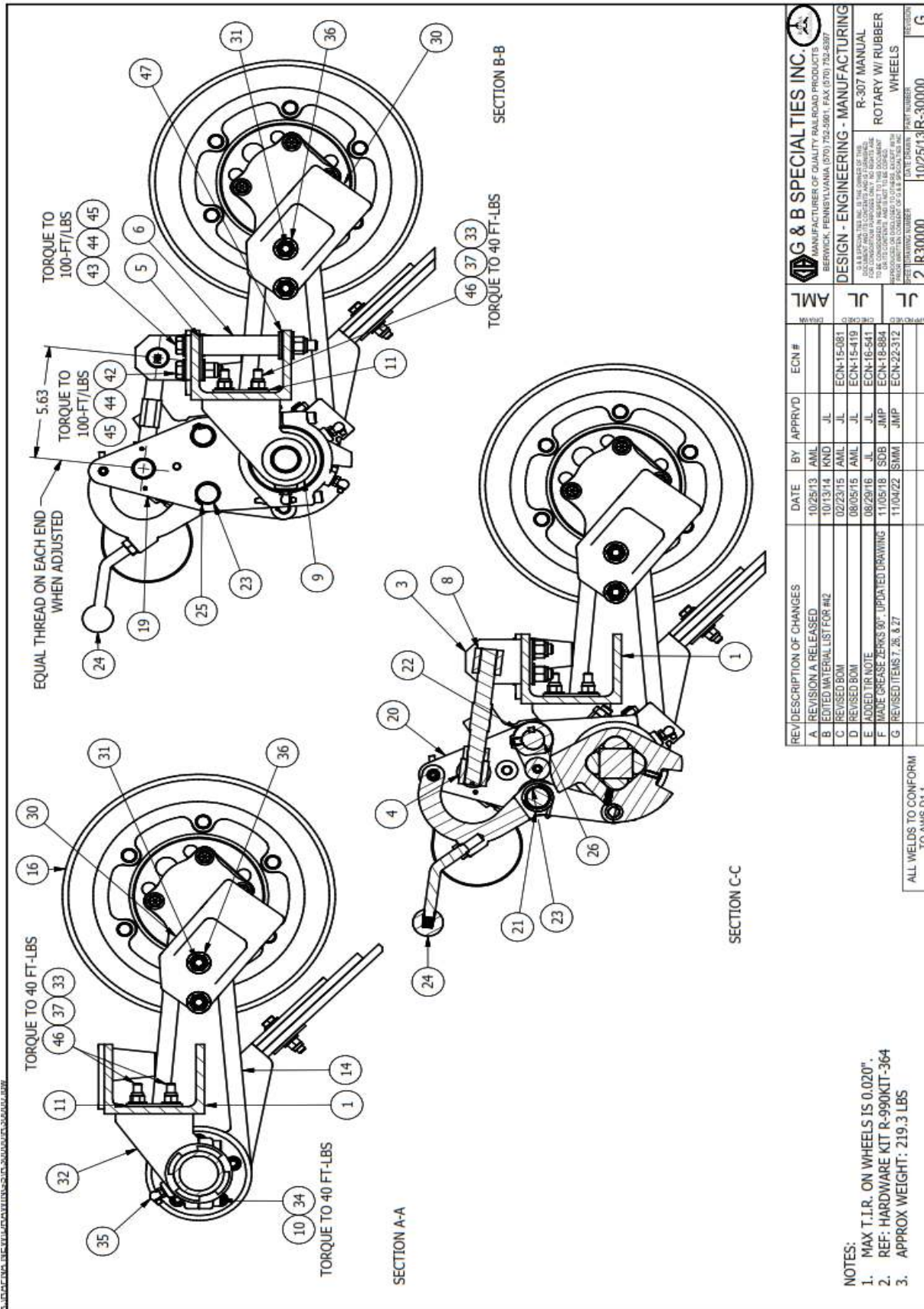

REVISION	DATE	BY	APPRVD	ECN #
A	10/25/13	AML		
B	10/13/14	KND	JL	
C	02/23/15	AML	JL	ECN-15-081
D	08/05/15	AML	JL	ECN-15-419
E	08/20/16	JL	JL	ECN-16-541
F	11/05/18	SDB	JMP	ECN-18-884
G	11/04/22	SMM	JMP	ECN-22-312

REVISION	DATE	BY	APPRVD	ECN #
A	10/25/13	AML		
B	10/13/14	KND	JL	
C	02/23/15	AML	JL	ECN-15-081
D	08/05/15	AML	JL	ECN-15-419
E	08/20/16	JL	JL	ECN-16-541
F	11/05/18	SDB	JMP	ECN-18-884
G	11/04/22	SMM	JMP	ECN-22-312

ALL WELDS TO CONFORM TO AWS D1.1

G & B SPECIALTIES INC.
 MANUFACTURER OF DUALITY RAILROAD PRODUCTS
 BERWICK, PENNSYLVANIA (717) 752-5901, FAX: (717) 752-6397

DESIGN - ENGINEERING - MANUFACTURING

R-307 MANUAL
 ROTARY W/ RUBBER
 WHEELS

2 R30000 10/25/13R-30000

- NOTES:
1. MAX T.I.R. ON WHEELS IS 0.020".
 2. REF: HARDWARE KIT R-990KIT-364
 3. APPROX WEIGHT: 219.3 LBS

BILL OF MATERIAL/PARTS LIST			BILL OF MATERIAL/PARTS LIST				
ITEM	PART NUMBER	DESCRIPTION	QTY	ITEM	PART NUMBER	DESCRIPTION	QTY
1	R-30058	SUPPORT FRAME ASSY	1	26	R-30057L	PIVOT SHAFT ASSY, LH	1
2	R-30060	BUMP STOP	2	27	R-30057R	PIVOT SHAFT ASSY, RH	1
3	R-30024	MTG ANGL	4	28	R-30074	WASHER	2
4	R-30052	ADJ BLK, LH	2	29	R-30010R	DE-RAIL SKID, RH	1
5	R-30023A	BACKER PLATE	4	30	R-30010L	DE-RAIL SKID, LH	1
6	R-30022	STAND-OFF	2	31	R-30076	H.H.C.S., FLANGED	4
7	R-30051	ADJUSTING ROD	2	32	R-30017B	SUPPORT BEARING, SPLIT	2
8	R-30053	ADJ BLK, RH	2	33		3/8" UNC GR.8	18
9	R-30019	SUPPORT BEARING ASSY	2	34		3/8" UNC x 1.25	8
10	R-30035	LOCK WASHER	8	35	990900-008	1/8 NPT 90° ZERK	2
11	R-30023	BACKER PLATE	4	36		1/2" UNC GR.8, FLANGED	4
12	R-30225L	TORSION ASSEMBLY, LH	1	37		3/8" GR.8 TYPE-A	26
13	R-30225R	TORSION ASSEMBLY, RH	1	38		5/16" UNC GR.5, JAM	2
14	R-30070	DROP ARM ASSY	2	39		3/8" UNC GR.8 x 3.50	10
15	R-30018	FELT SEAL	8	40		3/4" UNF GR.8	2
16	R-30001	10" WHEEL ASSY, RUBBER	2	41		3/8" UNF x 1.50	2
17	R-30006	WASHER, LUG NUT	10	42		1/2" UNC GR.8 x 1.75	6
18	R-30004	LUG NUT	10	43		1/2" UNC GR.8 x 6.00	2
19	R-30034	INNER SUPPORT PLATE ASSY	2	44		1/2" UNC GR.8 TYPE A	18
20	R-30026	OUTER SUPPORT PLATE ASSY	2	45		FWASHER	8
21	R-30054	TORSION SPRING	2	46		NYLOCK NUT	8
22	R-30048	ROLLER ARM ASSY	2	47		H.H.C.S.	8
23	R-30043	FIN	2	48		R-30030DFFR	10
24	R-30036	ACTUATOR ASSY	2	49		RAIL SWEEP ASSEMBLY	1
25	R-30044	RETAINING RING	8			RAIL SWEEP ASSEMBLY	1

NOTES:

1. MAX T.I.R. ON WHEELS IS 0.020" .
2. REF: HARDWARE KIT R-990KIT-364
3. APPROX WEIGHT: 219.3 LBS

REV	DESCRIPTION OF CHANGES	DATE	BY	APPROV	ECN #	DRW	AML	REVISIONS
A	REVISION A RELEASED	10/25/13	AML					
B	EDITED MATERIAL LIST FOR #12	10/13/14	KND	JL				
C	REVISED BOM	02/23/15	AML	JL	ECN-15-081			
D	REVISED BOM	08/05/15	AML	JL	ECN-15-419			
E	ADDED TR NOTE	08/20/16	JL	JL	ECN-16-541			
F	MADE GREASE ZERKS 90° UPDATED DRAWING	11/05/18	SOB	JMP	ECN-18-864			
G	REVISED ITEMS 7, 26, & 27	11/04/22	SMI	JMP	ECN-22-312			

ALL WELDS TO CONFORM TO AWS D1.1

3	R30000	10/25/16	R-30000					
---	--------	----------	---------	--	--	--	--	--

G & B SPECIALTIES INC.
MANUFACTURER OF QUALITY RAILROAD PRODUCTS
BERWICK, PENNSYLVANIA (570) 752-5901, FAX (570) 752-6397
DESIGN - ENGINEERING - MANUFACTURING
R-307 MANUAL
ROTARY W/ RUBBER
WHEELS

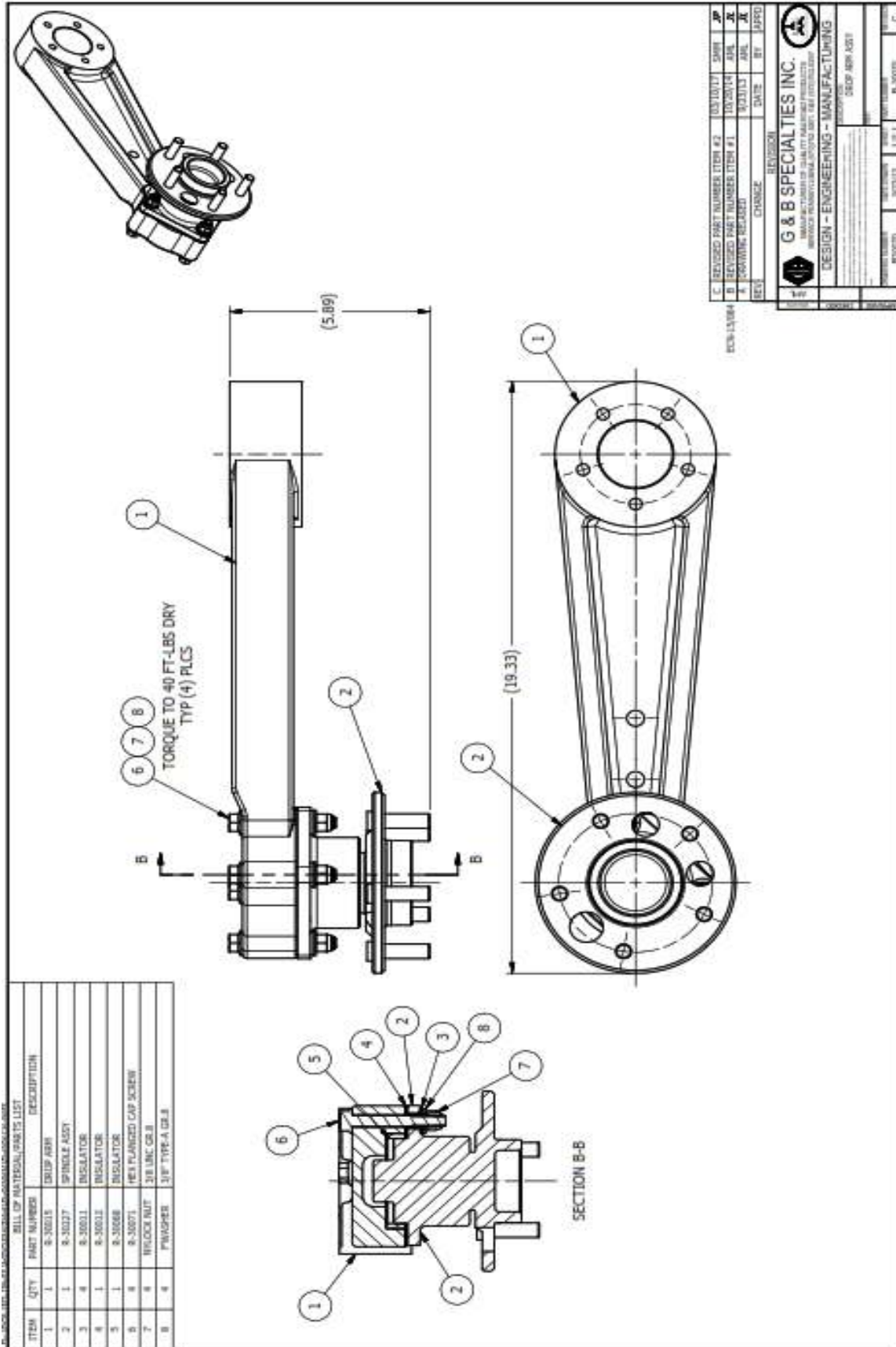

ITEM	QTY	PART NUMBER	DESCRIPTION
1	1	R-30073R	TORSION COUPLING, RH
2	4	R-30226	TORSION CORD
3	4	R-30090	Hexagon Socket Set Screw - Oval Point, 1/2" x 2"
4	1	R-30150	TORQUE SHAFT ASSEMBLY
5	4	H-00003	HEX NYLOCK JAM NUT, 1/2" UNC
6	2	R-33506	SCREW, .0250 X 0.750 CUP PT SET

DETAIL B
SCALE .625

SECTION A-A
0.56

90° 180°

0° 90° 180°

DATE BY APPROVD ECN #

10/17/14 AML JL ECN-15-085

10/21/17 AML JL ECN-15-428

08/07/15 AML JL ECN-15-428

11/12/18 SDB JMP ECN-18-920

REVISION DESCRIPTION OF CHANGES

A REVISION A RELEASED

B REVISED BOM

C REVISED BOM

D ADDED SET SCREW R-33506

ALL WELDS TO CONFORM TO AWS D.1.1

NOTES:

- ASSEMBLE AS SHOWN PER ASSEMBLY PROCEDURE: ASP-307-1
- ORIENTATION OF BOLT PATTERN AND TORSION COUPLING IS CRITICAL TO FUNCTION OF PART
- ONLY ONE HOLE AND ONE FLAT ARE WELDED IN-LINE ON ITEM #1 AND SHOULD BE ORIENTED AT 180° AS SHOWN
- ASSEMBLY THREADED COMPONENTS WITH LOCTITE 243 (BLUE) THREAD LOCKER OR EQUIVALENT
- APPROX. WEIGHT: 31.5 LBS

G & B SPECIALTIES INC. MANUFACTURER OF QUALITY RAILROAD PRODUCTS BERWICK, PENNSYLVANIA (570) 752-5901, FAX: (570) 752-6397	DESIGN - ENGINEERING - MANUFACTURING <small>IT IS G&B SPECIALTIES INC.'S POLICY TO OBTAIN THE SERVICES OF QUALIFIED PROFESSIONALS IN THE DESIGN AND MANUFACTURE OF ALL PRODUCTS. THE QUALITY OF ALL PRODUCTS IS ASSURED BY THE COMPANY'S ISO 9001 CERTIFICATION AND THE COMPANY'S COMMITMENT TO EXCELLENCE.</small>	TORSION ASSEMBLY, RH
AML	JL	JL
1	R30225R	10/17/14 R-30225R
1	R30225R	10/17/14 R-30225R
1	R30225R	10/17/14 R-30225R

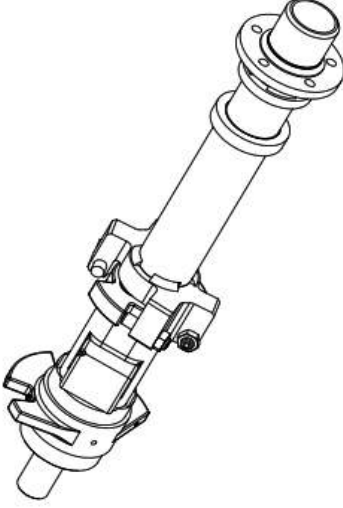
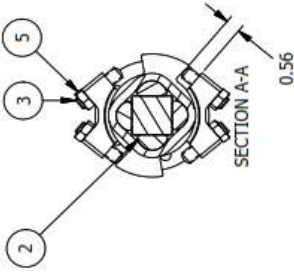
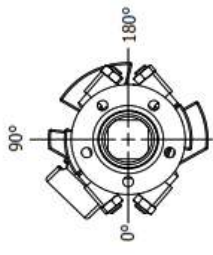
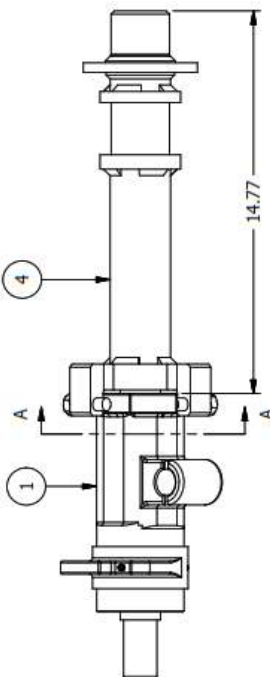
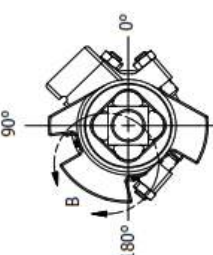
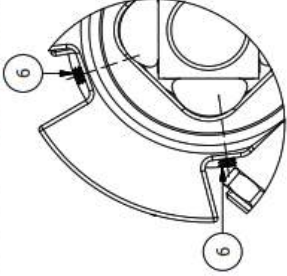
DETAIL B
SCALE .625

ITEM	QTY	PART NUMBER	DESCRIPTION
1	1	R-30072L	TORSION COUPLING, LH
2	4	R-30226	TORSION CORD
3	4	R-30090	Hexagon Socket Set Screw - Oval Point, 1/2" UNC x 2"
4	1	R-30150	TORQUE SHAFT ASSEMBLY
5	4	H-00003	HEX NYLOCK JAM NUT, 1/2" UNC
6	2	R-33506	SCREW .0250 X 0.750 CLIP PT SET

NOTES:

- ASSEMBLE AS SHOWN PER ASSEMBLY PROCEDURE: ASP-307-1
- ORIENTATION OF BOLT PATTERN AND TORSION COUPLING IS CRITICAL TO FUNCTION OF PART
- ONLY ONE HOLE AND ONE FLAT ARE WELDED IN-LINE ON ITEM #1 AND SHOULD BE ORIENTED AT 0° AS SHOWN (BLUE) THREADED COMPONENTS WITH LOCTITE 243
- APPROX. WEIGHT: 31.5 LBS

ALL WELDS TO CONFORM TO AWS D1.1

REV/DESCRIPTION OF CHANGES	DATE	BY	APPROVD	ECN #	APPROVAL
A. REVISION A RELEASED	10/17/14	AML	JL	ECN-15-088	AML
B. REVISED BOM	09/21/17	AML	JL	ECN-15-429	JL
C. REVISED BOM	09/07/15	AML	JL	ECN-15-429	JL
D. ADDED SET SCREW R-33506	11/12/18	SDB	JMP	ECN-18-921	JL

G & B SPECIALTIES INC.
MANUFACTURER OF QUALITY RAILROAD PRODUCTS
BERWICK, PENNSYLVANIA (717) 752-5901 FAX (717) 752-6397

DESIGN - ENGINEERING - MANUFACTURING

G & B SPECIALTIES INC. IS THE OWNER OF THIS DOCUMENTATION. IT IS THE PROPERTY OF G & B SPECIALTIES INC. AND IS TO BE USED ONLY FOR THE PROJECT AND QUANTITY SPECIFIED. ANY REPRODUCTION OR DISTRIBUTION WITHOUT WRITTEN CONSENT OF G & B SPECIALTIES INC. IS PROHIBITED.

TORSION ASSEMBLY, LH

REV: R30225L

DATE: 10/17/14

REV: R-30225L

REV: D

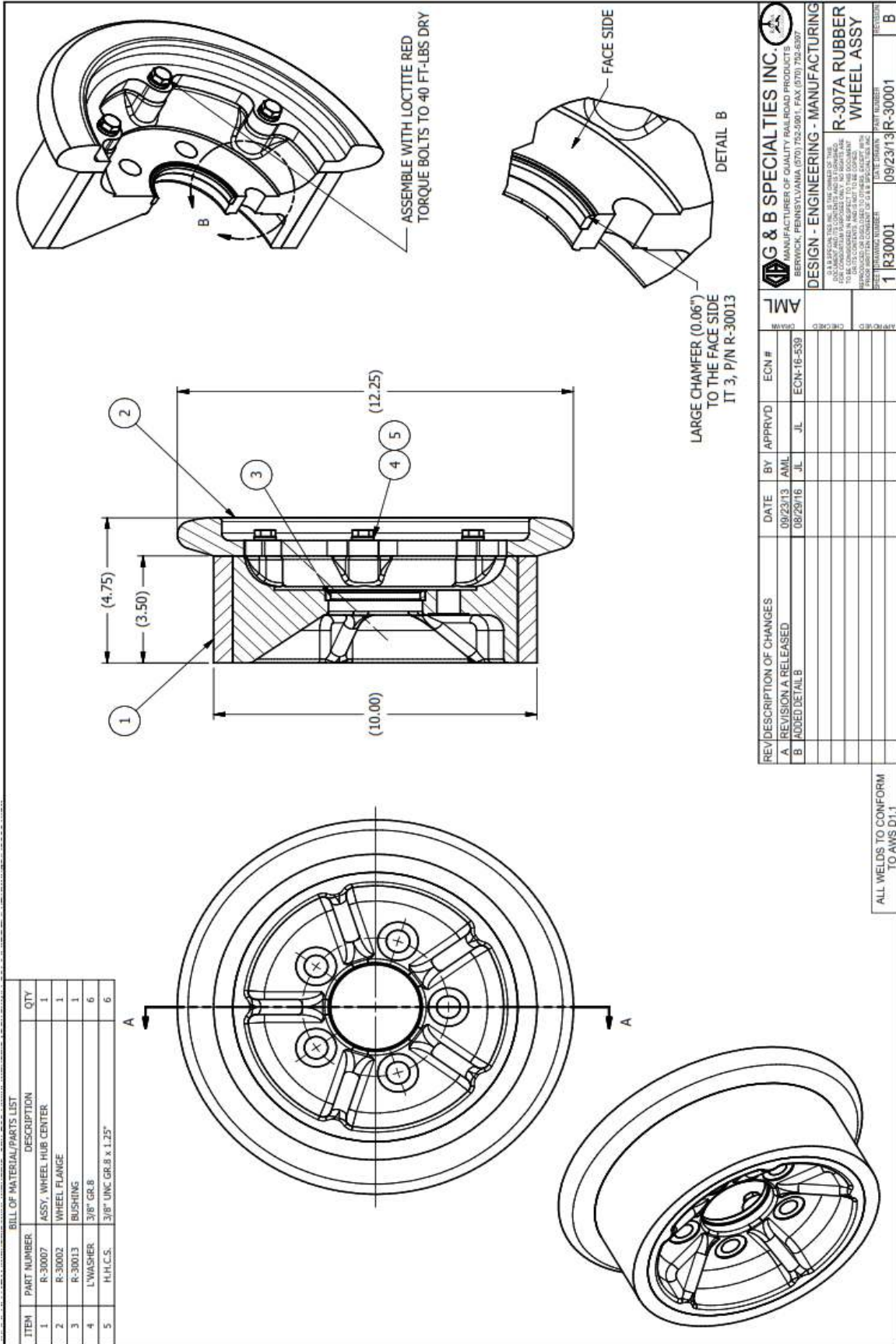

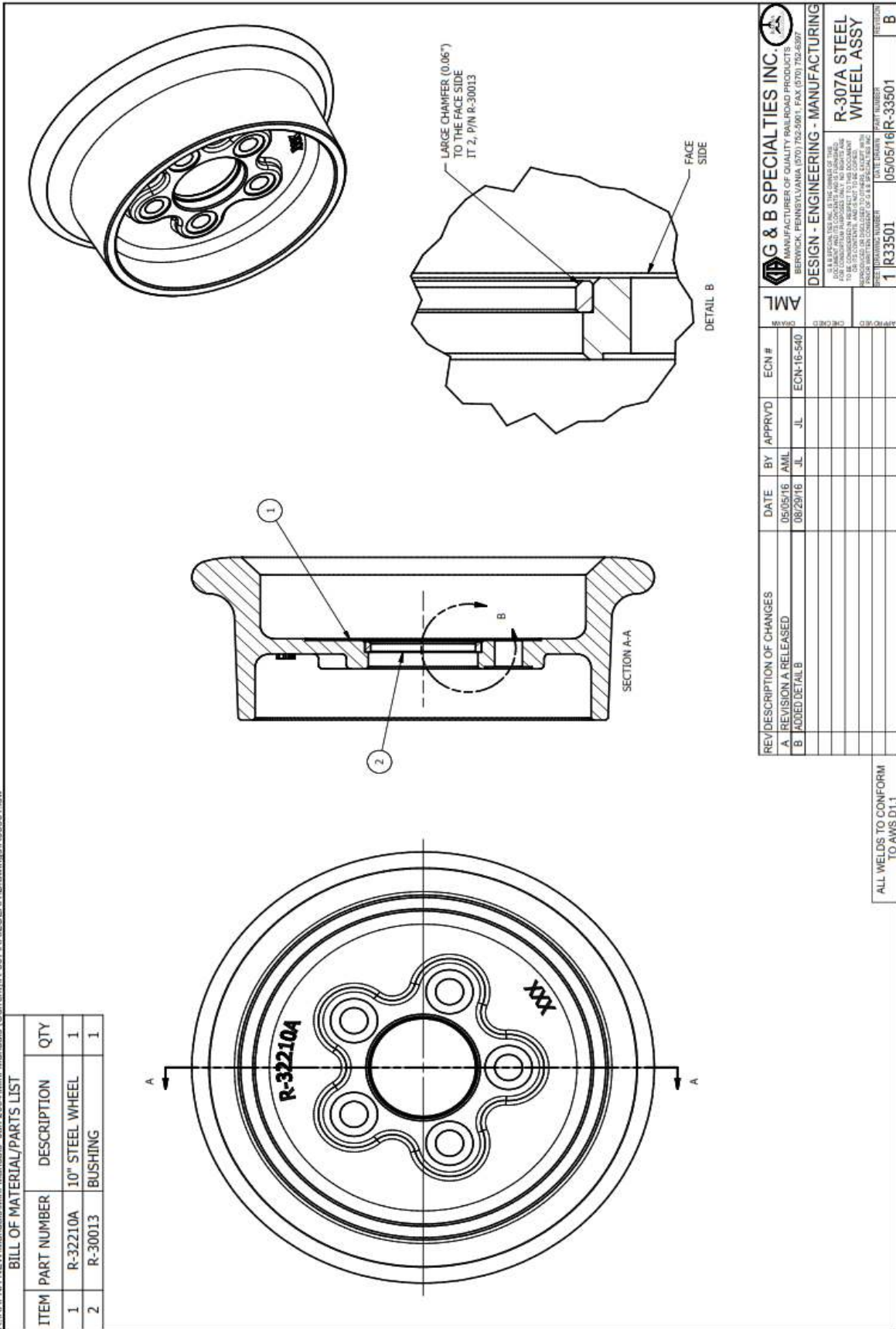

 G & B SPECIALTIES INC. MANUFACTURER OF QUALITY RAILROAD PRODUCTS BERWICK, PENNSYLVANIA (717) 752-5901 FAX (717) 752-6397		DESIGN - ENGINEERING - MANUFACTURING R-307A STEEL WHEEL ASSY	
REVISION A RELEASED B ADDED DETAIL B	DATE 05/05/16 06/29/16	BY AML JL	APPROVD JL
ECN # ECN-16-540	DATE DRAWN 05/05/16		
ALL WELDS TO CONFORM TO AWS D1.1		PART NUMBER R-33501	RETWORK B

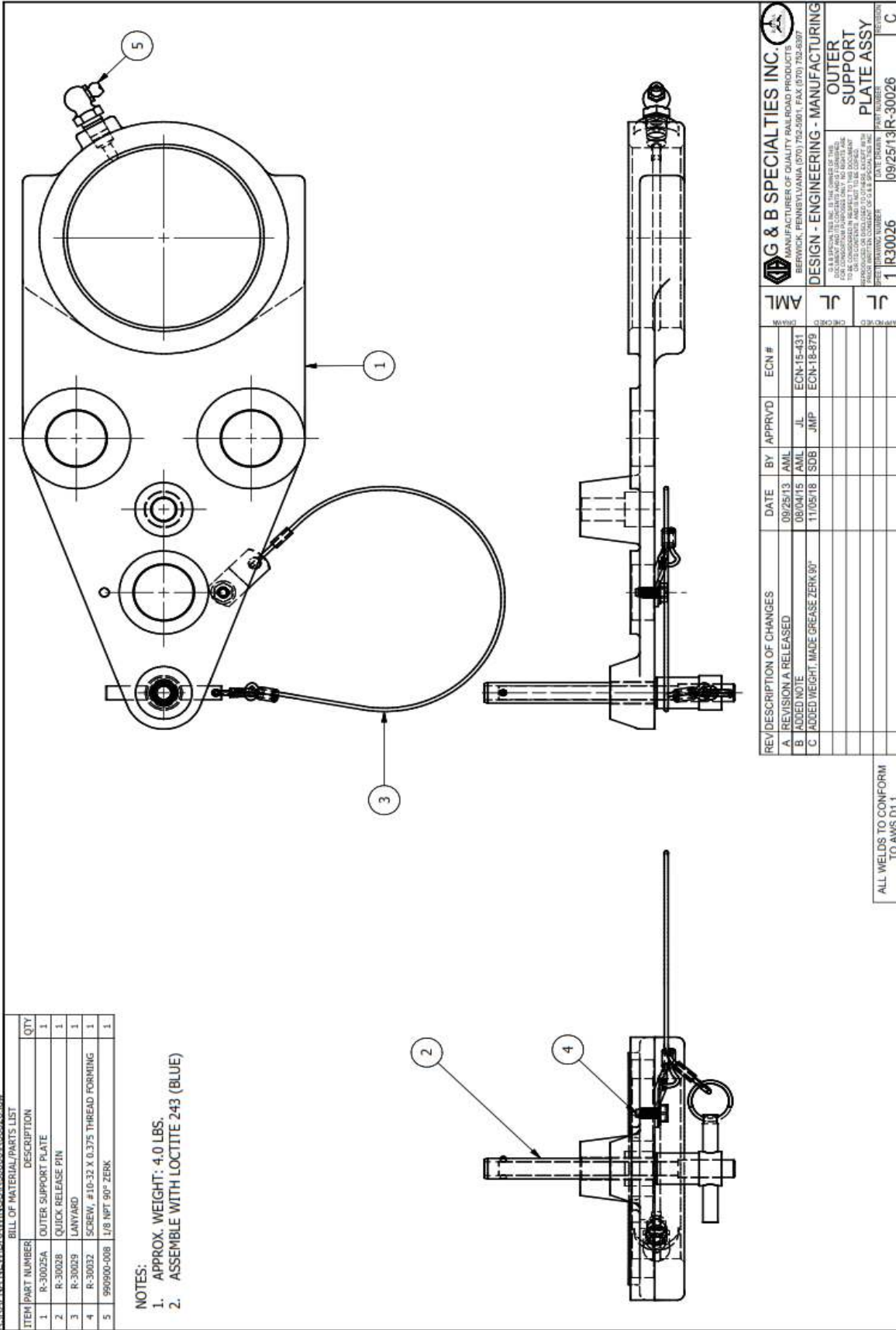

BILL OF MATERIAL/PARTS LIST

ITEM #	PART NUMBER	DESCRIPTION	QTY
1	R-30025A	OUTER SUPPORT PLATE	1
2	R-30028	QUICK RELEASE PIN	1
3	R-30029	LANYARD	1
4	R-30032	SCREW, #10-32 X 0.375 THREAD FORMING	1
5	990900-008	1/8 NPT 90° ZERK	1

NOTES:
1. APPROX. WEIGHT: 4.0 LBS.
2. ASSEMBLE WITH LOCTITE 243 (BLUE)

REV/DESCRIPTION OF CHANGES

REV	DESCRIPTION OF CHANGES	DATE	BY	APPROVD	ECN #
A	REVISION A RELEASED	09/25/13	AML	JL	ECN-15-431
B	ADDED NOTE	06/04/15	AML	JL	ECN-18-879
C	ADDED WEIGHT MADE GREASE ZERK 90°	11/05/18	SOB	JMP	ECN-18-879

G & B SPECIALTIES INC.
MANUFACTURER OF DUALITY RAILROAD PRODUCTS
BERWICK, PENNSYLVANIA (570) 752-5901, FAX (570) 752-6397

DESIGN - ENGINEERING - MANUFACTURING

0.8.8 SPEC. THIS INC. IS THE OWNER OF THE
INFORMATION CONTAINED HEREIN. IT IS THE PROPERTY OF
G&B SPECIALTIES INC. AND IS TO BE KEPT IN CONFIDENTIALITY
AND NOT TO BE REPRODUCED OR TRANSMITTED IN ANY FORM OR
BY ANY MEANS, ELECTRONIC OR MECHANICAL, INCLUDING
PHOTOCOPYING, RECORDING, OR BY ANY INFORMATION STORAGE
AND RETRIEVAL SYSTEM, WITHOUT THE WRITTEN PERMISSION
OF G&B SPECIALTIES INC.

DATE DRAWN: 09/25/13
DATE CHECKED: 09/25/13
DATE APPROVED: 09/25/13

1 R30026
1 R30026

OUTER SUPPORT PLATE ASSY

ALL WELDS TO CONFORM TO AWS D1.1

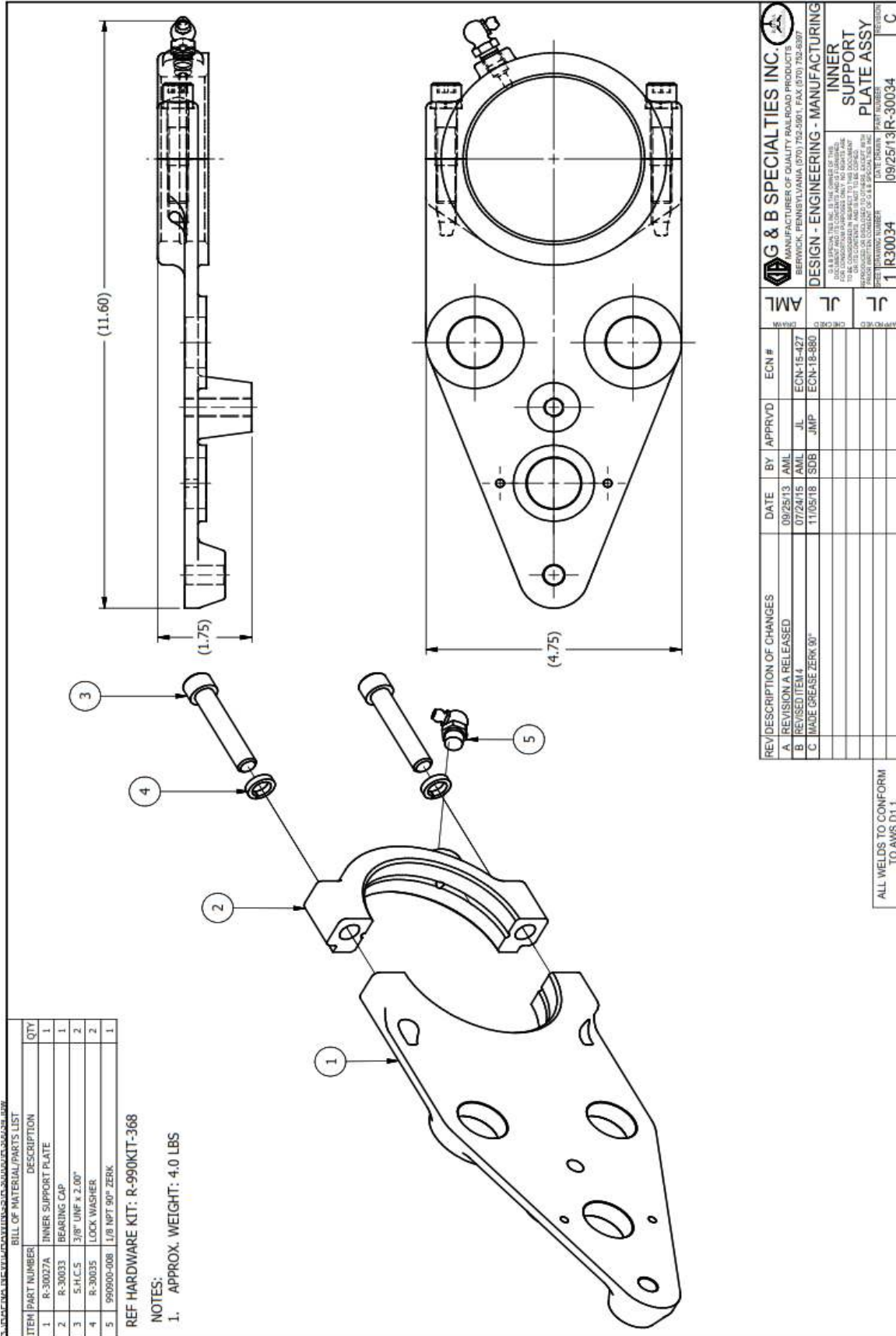

BILL OF MATERIAL/PARTS LIST			
ITEM	PART NUMBER	DESCRIPTION	QTY
1	R-30037	ACTUATOR	1
2	R-30038	LEVER	1
3	R-30039	KNOB	1
4	HEX NUT	1/2" UNC GR.8 REG JAM	1
5	R-30040	ROLLER	1
6	R30042	RETAINING RING	2
7	R-30041	PIN	1

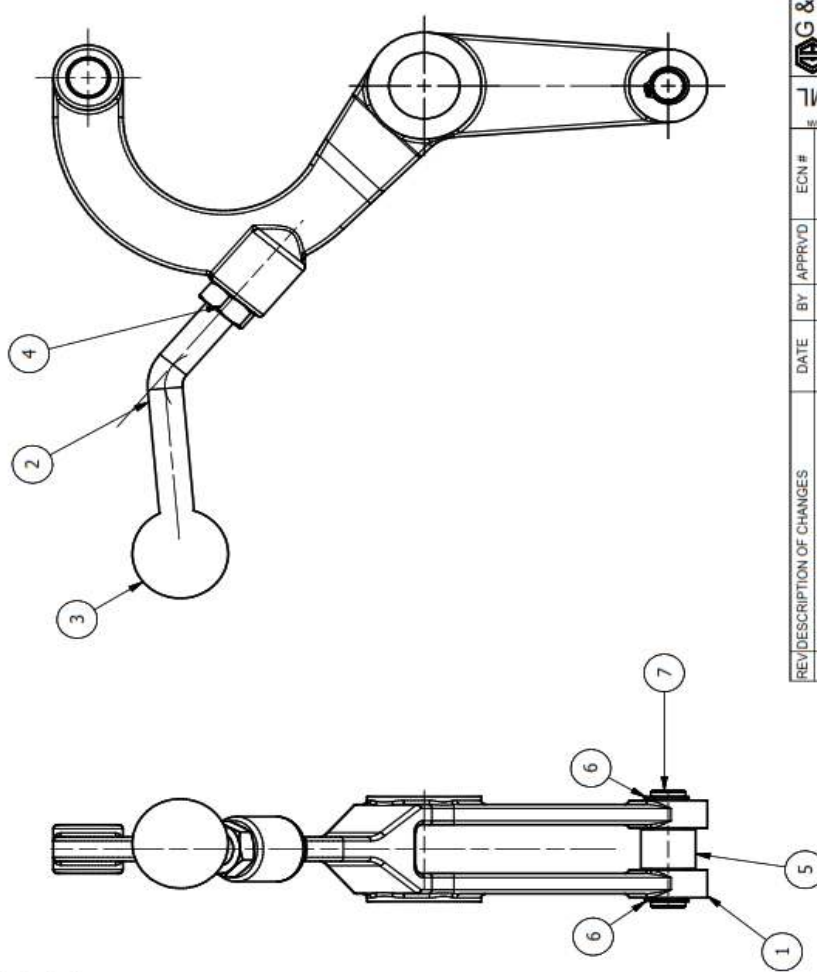

REV/DESCRIPTION OF CHANGES	DATE	BY	APPRVD	ECN #	AM/REV
A REVISION A RELEASED	09/25/13	AML			

	G & B SPECIALTIES INC. MANUFACTURER OF QUALITY PNEUMATIC PRODUCTS BERWICK, PENNSYLVANIA (570) 752-5901 FAX (570) 752-6397
DESIGN - ENGINEERING - MANUFACTURING	ACTUATOR ASSY
DATE DRAWN: 09/25/13	PART NUMBER: R-30036
DATE CHECKED: 09/25/13	REV NUMBER: 1
DATE APPROVED: 09/25/13	REV DESCRIPTION: A

ALL WELDS TO CONFORM TO AWS D1.1

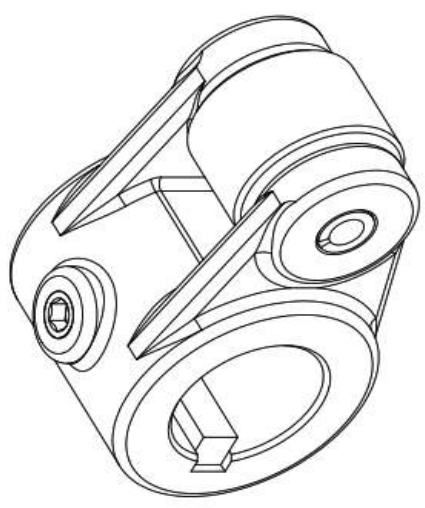
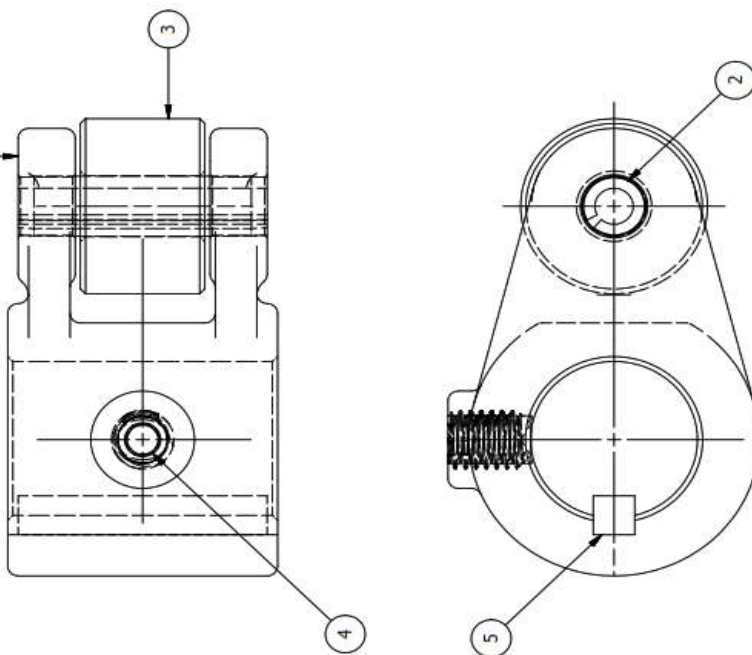
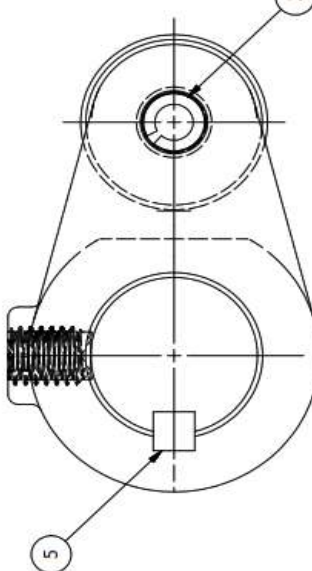
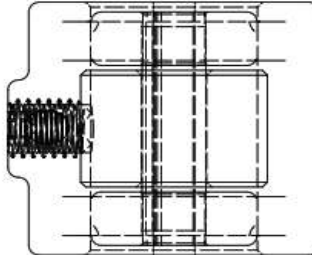





BILL OF MATERIAL/PARTS LIST			
ITEM	PART NUMBER	DESCRIPTION	QTY
1	R-30047	ROLLER ARM	1
2	R-30046	SPRING PIN	1
3	R-30045	ROLLER	1
4	R-30049	SET SCREW	1
5	R-30050	SHAFT KEY	1

REV/DESCRIPTION OF CHANGES	DATE	BY	APPROVD	ECN #	AML	AML	AML
A. REVISION A RELEASED	09/27/13	AML	JAMP	ECN-18-970	AML	AML	AML
B. UPDATED BALLOON FOR ITEM#5	11/29/18	SDB	JAMP		AML	AML	AML

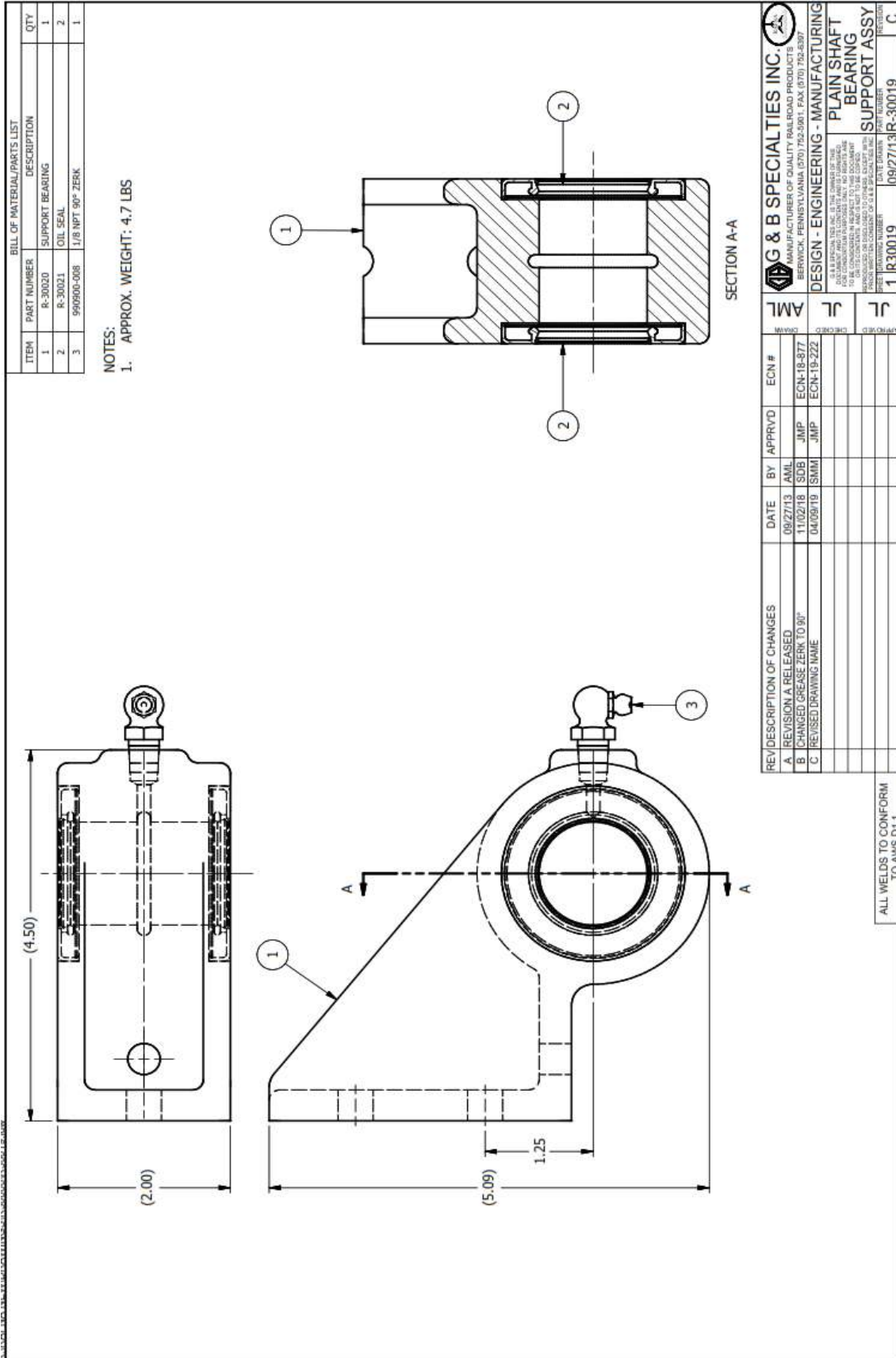
 G & B SPECIALTIES INC. MANUFACTURER OF QUALITY RAILROAD PRODUCTS BERWICK, PENNSYLVANIA (717) 752-5901 FAX (717) 752-6397	
DESIGN - ENGINEERING - MANUFACTURING <small>ALL DIMENSIONS UNLESS OTHERWISE SPECIFIED ARE IN INCHES AND DECIMALS THEREOF. DIMENSIONS IN PARENTHESES INDICATE DIMENSIONS FOR COMPONENTS PURCHASED ONLY. NO DIMENSIONS ARE TO BE TAKEN FROM THIS DRAWING UNLESS OTHERWISE SPECIFIED. THIS DRAWING IS THE PROPERTY OF G&B SPECIALTIES INC. IT IS TO BE KEPT IN CONFIDENCE AND NOT TO BE REPRODUCED OR TRANSMITTED IN ANY FORM OR BY ANY MEANS, ELECTRONIC OR MECHANICAL, INCLUDING PHOTOCOPYING, RECORDING, OR BY ANY INFORMATION STORAGE AND RETRIEVAL SYSTEM.</small>	
ITEM NO.	DESCRIPTION
1	R-30048
	ROLLER ARM ASSY
DATE	09/27/13
REV	R-30048
REV	B

ALL WELDS TO CONFORM TO AWS D1.1



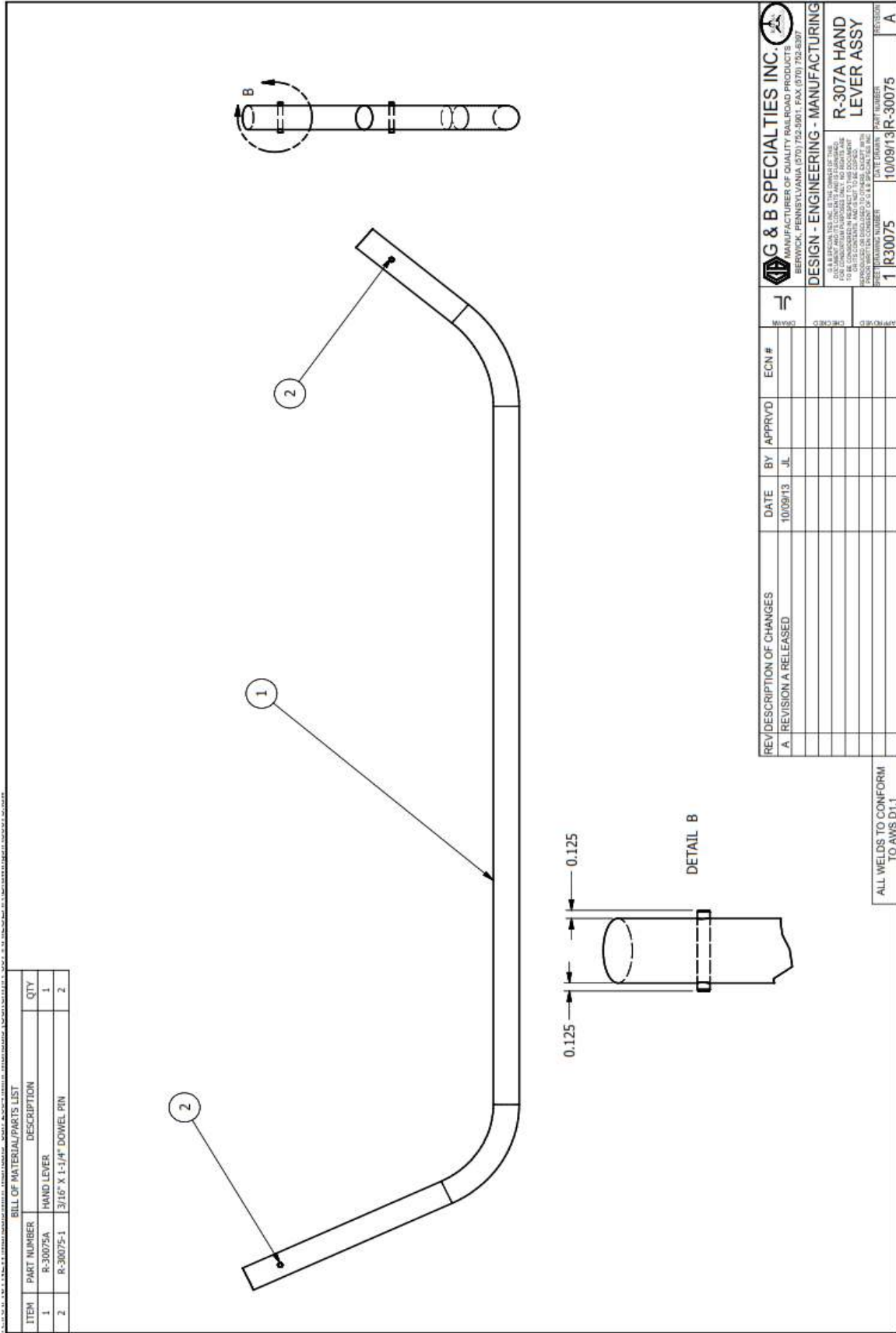

 G & B SPECIALTIES INC. MANUFACTURERS OF QUALITY RAILROAD PRODUCTS BERWICK, PENNSYLVANIA (717) 752-5901 FAX (717) 752-6397		DESIGN - ENGINEERING - MANUFACTURING R-307A HAND LEVER ASSY	
REVISION DESCRIPTION OF CHANGES A. REVISION A RELEASED	DATE 10/09/13	BY JL	APPROVED [Signature]
ECN #	DATE FORW. PART NUMBER 1000913R-30075	PART NUMBER 1000913R-30075	REVISION A

ALL WELDS TO CONFORM TO AWS D1.1

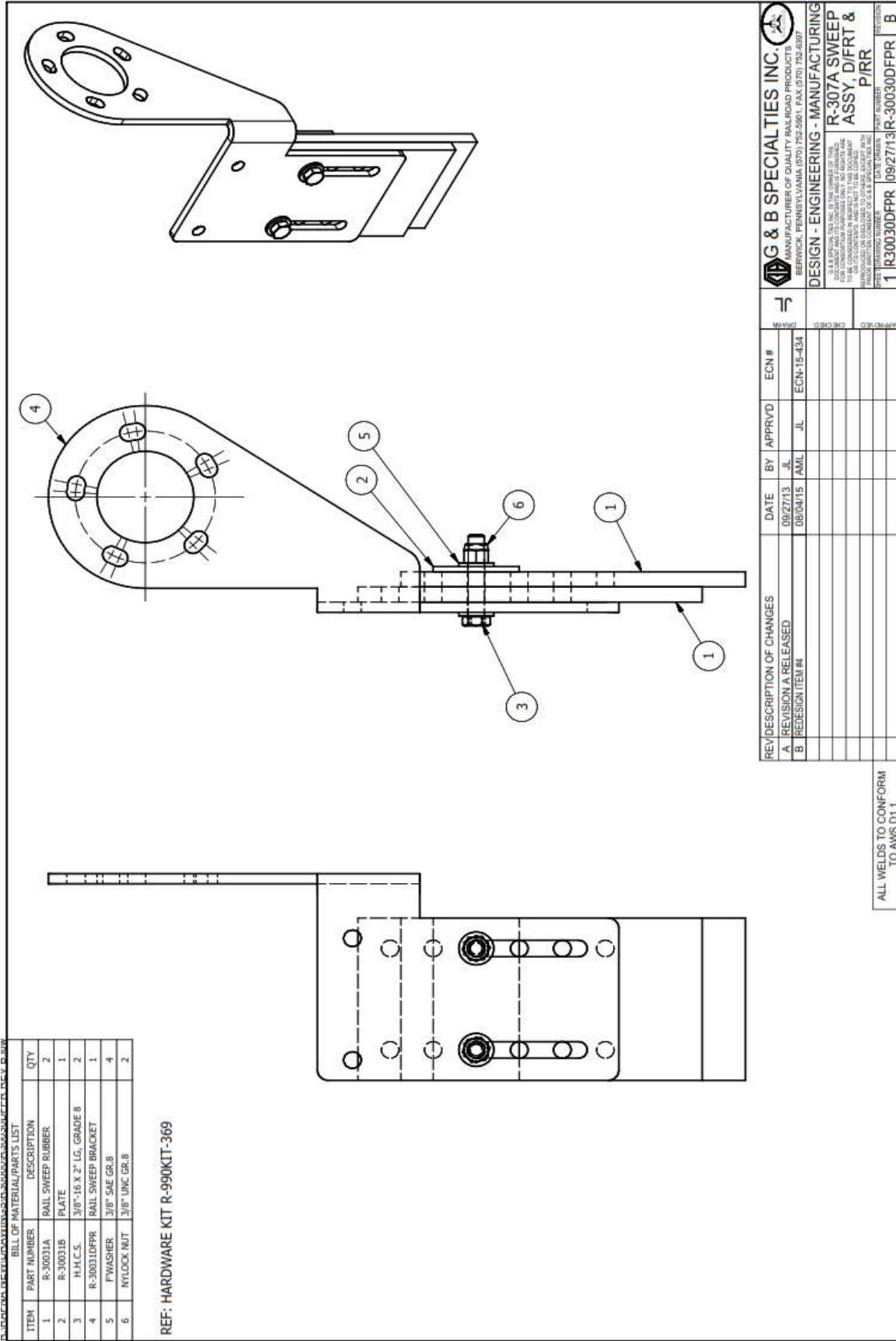

REF: HARDWARE KIT R-990KIT-369

ITEM	PART NUMBER	DESCRIPTION	QTY
1	R-30031A	RAIL SWEEP RUBBER	2
2	R-30031B	PLATE	1
3	H.H.C.S.	3/8" - 16 X 2" LG. GRADE 8	2
4	R-30031DPPR	RAIL SWEEP BRACKET	1
5	FWASHER	3/8" SAE GR.8	4
6	NYLOCK NUT	3/8" UNC GR.8	2

REF: HARDWARE KIT R-990KIT-369

 G & B SPECIALTIES INC. MANUFACTURERS OF QUALITY RAIL ROAD PRODUCTS BERWICK, PENNSYLVANIA (717) 752-5901 FAX (717) 752-6397	
DESIGN - ENGINEERING - MANUFACTURING R-307A SWEEP ASSY, D/FRT & P/RR	
DATE: 09/27/13 BY: J.L. APPROVD: J.L.	ECN # ECN-15-434
REV/DESCRIPTION OF CHANGES A REVISION A RELEASED B REDESIGN ITEM #	DATE 08/04/15 BY A.M.L.
SHEET NUMBER: 1 PART NUMBER: R30030DFPR DATE ISSUED: 09/27/13 REVISED: 09/27/13	DRAWN: [] CHECKED: [] APPROVED: []

ALL WELDS TO CONFORM TO AWS D1.1

BILL OF MATERIAL/PARTS LIST			
ITEM	PART NUMBER	DESCRIPTION	QTY
1	R30031A	RAIL SWEEP RUBBER	2
2	R30031B	PLATE	1
3	H.H.C.S.	3/8"-16 X 2" LG GRADE B	2
4	F'WASHER	3/8" TYPE A GRADE B	4
5	R30031PDR	RAIL SWEEP BRACKET	1
6	NYLOCK NUT	3/8" UNC GRADE B	2

REFERENCE HARDWARE KIT : R-990KIT-369

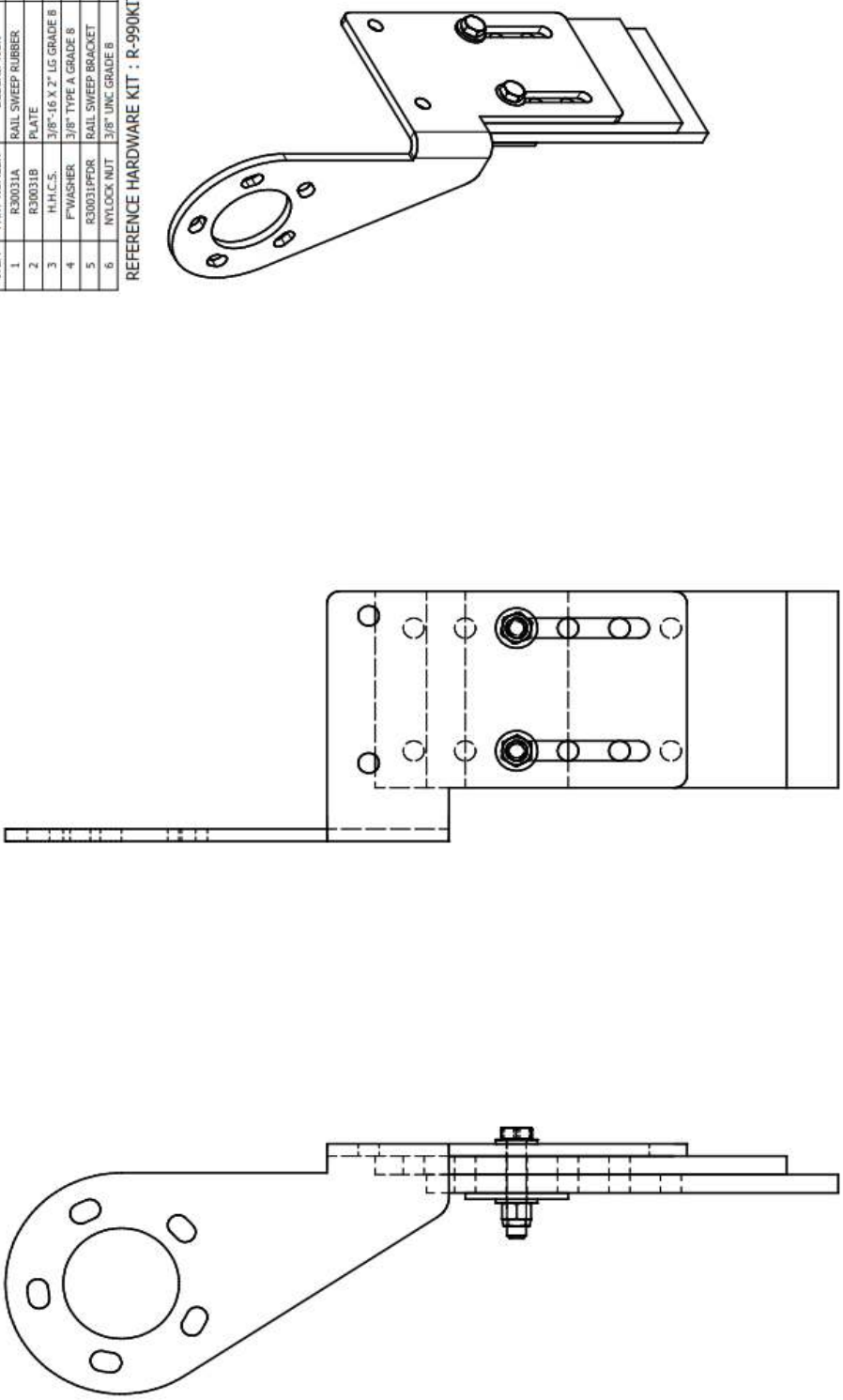



G & B SPECIALTIES INC.
MANUFACTURER OF QUALITY RAILROAD PRODUCTS
BERWICK, PENNSYLVANIA (570) 752-5991, FAX (570) 752-6397

DESIGN - ENGINEERING - MANUFACTURING

**R-307A SWEEP
ASSY, P/FR &
DIRR**

FOR PART NUMBER: R-307A SWEEP ASSY, P/FR & DIRR
FOR PART NUMBER: R-307A SWEEP ASSY, P/FR & DIRR
FOR PART NUMBER: R-307A SWEEP ASSY, P/FR & DIRR

FOR PART NUMBER: R-307A SWEEP ASSY, P/FR & DIRR

REVISION	DATE	BY	APPROVED	ECN #
A. REVISION A RELEASED	09/27/13	JL	JL	ECN-15-435
B. REDESIGN ITEM #5	08/04/15	AML	JL	

ALL WELDS TO CONFORM TO AWS D1.1

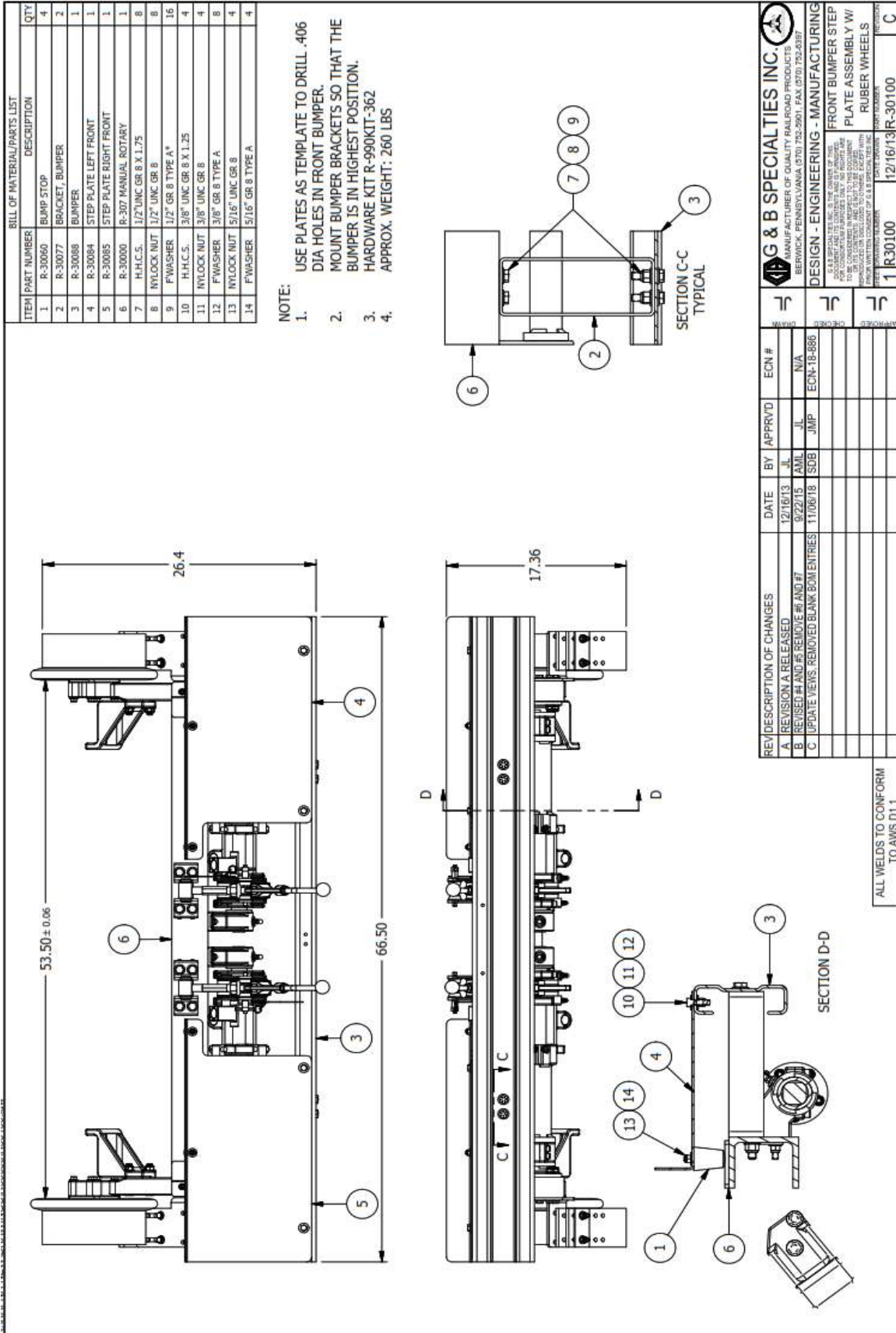

BILL OF MATERIAL/PARTS LIST			QTY
ITEM	PART NUMBER	DESCRIPTION	
1	R-30000	R-307 MANUAL ROTARY	1
2	R-30082	STEP RIGHT SIDE	1
3	R-30083	STEP LEFT SIDE	1
4	R-30077	BRACKET, BUMPER	2
5	R-30088	BUMPER	1
6	H.H.C.S.	1/2" UNC GR 8 X 1.75	8
7	NYLOCK NUT	1/2" UNC GR 8	8
8	FWASHER	1/2" UNC GR 8	16
9	H.H.C.S.	3/8" UNC GR 8 X 1.25	4
10	NYLOCK NUT	3/8" UNC GR 8	4
11	FWASHER	3/8" GR 8 TYPE A	8
12	NYLOCK NUT	5/16" UNC GR 8	4
13	FWASHER	5/16" GR 8 TYPE A	4
14	R-30060	BUMP STOP	4

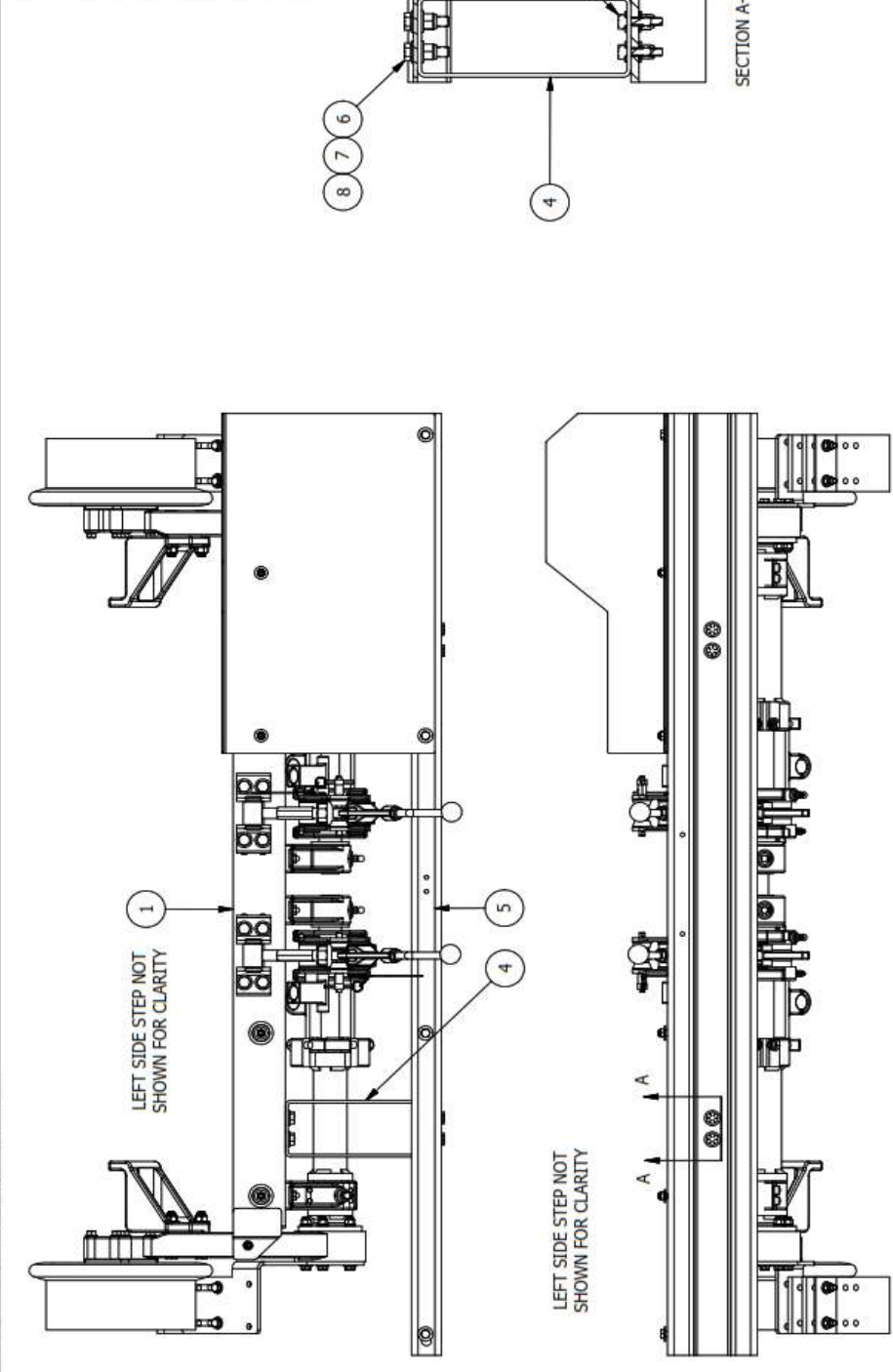

LEFT SIDE STEP NOT SHOWN FOR CLARITY

LEFT SIDE STEP NOT SHOWN FOR CLARITY

SECTION A-A

8 7 6

4

6 7 8

REV/DESCRIPTION OF CHANGES	DATE	BY	APPROVD	ECN #	STATUS
A REVISION A RELEASED	12/16/13	JL	JMP	ECN-18-889	RELEASED
B UPDATED DRAWING VIEWS	11/06/18	SDB	JMP	ECN-18-889	RELEASED

REAR BUMPER STEP
PLATE ASSEMBLY W/
RUBBER WHEELS

DESIGN - ENGINEERING - MANUFACTURING

REAR BUMPER STEP
PLATE ASSEMBLY W/
RUBBER WHEELS

1 R30101 12/16/13 R-30101 B

ALL WELDS TO CONFORM TO AWS D1.1

NOTES:

- USE PLATES AS TEMPLATE TO DRILL .406 DIA HOLES IN REAR BUMPER
- MOUNT BUMPER BRACKETS SO THAT THE BUMPER IS IN HIGHEST POSITION
- HARDWARE KIT, R-990KIT-363
- APPROX. WEIGHT: 250 LBS

BILL OF MATERIAL/PARTS LIST			
ITEM	PART NUMBER	DESCRIPTION	QTY
1	R-30000	R-307 MANUAL ROTARY	1
2	R-30082	STEP RIGHT SIDE	1
3	R-30083	STEP LEFT SIDE	1
4	R-30077	BRACKET, BUMPER	2
5	R-30088	BUMPER	1
6	H.H.C.S.	1/2" UNC GR 8 X 1.75	8
7	INTLOCK NUT	1/2" UNC GR 8	8
8	FWASHER	1/2" UNC GR 8	16
9	H.H.C.S.	3/8" UNC GR 8 X 1.25	4
10	INTLOCK NUT	3/8" UNC GR 8	4
11	FWASHER	3/8" GR 8 TYPE A	8
12	INTLOCK NUT	5/16" UNC GR 8	4
13	FWASHER	5/16" GR 8 TYPE A	4
14	R-30060	BUMP STOP	4

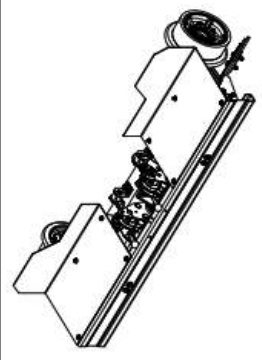
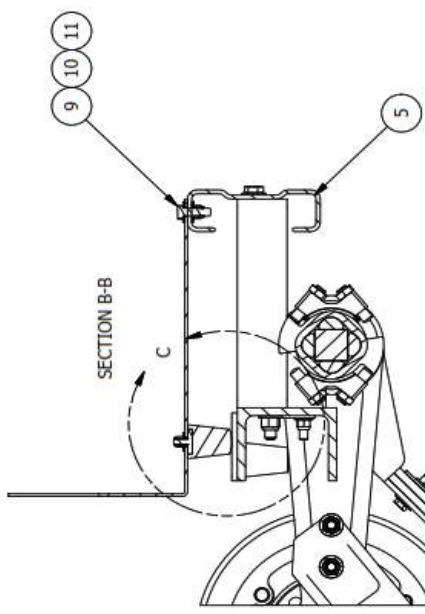
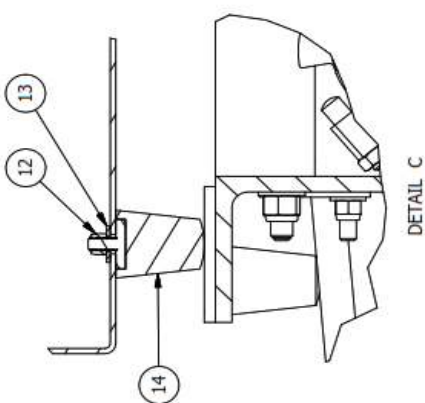
NOTES:

1. USE PLATES AS TEMPLATE TO DRILL .406 DIA HOLES IN REAR BUMPER
2. MOUNT BUMPER BRACKETS SO THAT THE BUMPER IS IN HIGHEST POSITION
3. HARDWARE KIT, R-990KIT-363
4. APPROX. WEIGHT: 250 LBS

REVISION	DESCRIPTION OF CHANGES	DATE	BY	APPRVD	ECN #
A	REVISION A RELEASED	12/16/13	JL		ECN-18-889
B	UPDATED DRAWING VIEWS	11/06/18	SDB	JMP	ECN-18-889

REVISION	DESCRIPTION OF CHANGES	DATE	BY	APPRVD	ECN #
1	REAR BUMPER STEP PLATE ASSEMBLY WITH RUBBER WHEELS	12/16/13	JL		ECN-18-889
2	REAR BUMPER STEP PLATE ASSEMBLY WITH RUBBER WHEELS	12/16/13	JL		ECN-18-889

ALL WELDS TO CONFORM TO AWS D1.1

SIDE BAR ADAPTER TO "C" CHANNEL R307 MANUAL GEAR		
REV D	R-990KIT-389	10/27/2014
QUANTITY	DESCRIPTION	GRADE
8 REV C/D	SCREW, 0.375 UNC X 2.250 HEX CAP Z/Y	8
16	WASHER, 0.375 TYPE-A FLAT Z/Y	8
8	3/8" NYLOCK NUT	8
8 REV C	3/8 X 2" SQ WASHER, FASTENAL P/N 11101250	
G & B SPECIALTIES INC		

HARDWARE FOR MOUNTING OF R-307A RAILGEAR TO R-30062 MOUNTING BRACKET
ADAPTER

REV A		
R-990KIT-393		
R307A Railgear to Vehicle		
QUANTITY	DESCRIPTION	GRADE
12	WASHER, 0.500 TYPE A NARROW FLAT Z/Y	8
6	SCREW, 0.500 X 1.750 HEX CAP Z/Y	8
6	NUT, NYLOCK, 0.500 UNC Z/Y	8
G & B SPECIALTIES INC		

